

FACULTY OF ENGINEERING

B.E. 3/4 (Civil) II-Semester (Main) Examination, May / June 2015

Subject : Steel Structures

Time : 3 Hours

Max. Marks: 75

Note: Answer all questions of Part - A and answer any five questions from Part-B.**PART – A (25 Marks)**

- 1 List the hot rolled steel section used in practice. (2)
- 2 What are the various factors to be considered while calculating the wind pressure? (3)
- 3 What are the advantages of bolted connection over riveted or welded connection? (3)
- 4 A web of a plate girder consists of (800 x 12)mm plate of grade Fe 410 and is to be provided with a splice at a section where the factored shear and bending moment to be resisted by web are $V = 800$ kN and $M=250$ kNm. The flange plate thickness $2 \times 20 = 40$ mm each. Design a web splice. (3)
- 5 List some of the tension members used in buildings and bridges. (2)
- 6 What are the checks to be performed for beam member design? (2)
- 7 State the parameter that effect the strength of compression member. (3)
- 8 What is the main purpose of Laang and battens? (2)
- 9 State difference between purlin and girt. (2)
- 10 What are the load combinations that are usually considered for truss analysis? (3)

PART – B (50 Marks)

- 11 (a) Design a welded seat angle connection between a beam ISMB 300 and column ISHB 200 for a reaction of beam 100 kN, assuming Fe 410 grade steel ($F_y = 250$ MPa) and site welding. (5)
- (b) A member of a truss consists of two angles ISA 75 x 75 x 6 placed back to back. It carries an ultimate tensile load of 150 kN and is connected to a gusset plate 8mm thick placed in between the connected legs. Determine the number of 16mm diameter 4.6 grade bolts required for the joint. Assume F_u of plate as 410MPa. (5)
- 12 An ISA 150 x 115 x 8 is welded with the flange of a column ISHB 300. The bracket carries a factored load of 100 kN at a distance of 50 mm as shown in figure. Design the connection using Fe 410 grade. (10)

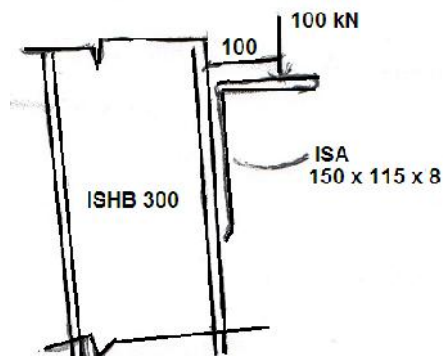

..2..

- 13 Design a simply supported beam of 7m span carrying a reinforced concrete floor capable of providing lateral restraint to the top compression flange. The total udl is made up of 100 kN dead load including self weight plus 150 kN imposed load. In addition, the beam carries a point load at mid span made up of 50 kN dead load and 50 kN imposed load (assuming a stiff length of 75 mm). (10)
- 14 Design a double angle discontinuous strut to carry a factored load of 175 kN. The length of strut is 3.0m between intersection. The two angles are placed back to back and are tack bolted. Consider the following cases.
(a) Angles are placed on opposite side of gusset plate
(b) Angles are placed on same side of gusset plate
Assume Fe 415 steel with $F_y=250$ MPa. (10)
- 15 Design a built up laced column with four angles to support axial load of 900 kN. The column is 12m long both ends are held in position and restrained against rotation. Assume Fe 410 grade steel. (10)
- 16 Design a base plate for a column of ISHB 200 carrying a factored load of 600 kN. Assume that the column is supported on a concrete of grade M25. (10)
- 17 The trusses for a factory building are spaced at 3.5 m c/c and the purlins are spaced at 1.0 m c/c. The pitch of truss is 1/3 and the span of the roof is 15 m. The vertical load from roof sheets is 250 N/m^2 and wind load normal to roof is 1400 N/m^2 . Design a channel section purlin. (10)

FACULTY OF ENGINEERING**B.E. 3/4 (EEE) II – Semester (Main) Examination, May / June 2015****Subject: Electrical Machinery – III****Time: 3 Hours****Max.Marks: 75***Note: Answer all questions from Part A and answer any five questions from Part B.***PART – A (25 Marks)**

- 1 A certain alternator has the ratio of slots to pole as 7. Find the frequencies due to slot harmonics if the generated emf has a frequency of 50 Hz. (3)
- 2 What is the chording angle to eliminate the 5th harmonic in the generated emf? (2)
- 3 Draw the phasor diagram of a salient pole generator operating at lagging power factor. (3)
- 4 Two alternators are synchronized together. Explain why they tend to remain in synchronism. (2)
- 5 What are inverted 'v' curves? (2)
- 6 What is synchronizing power for a salient pole motor, neglecting the armature resistance? (3)
- 7 Draw the waveform of the short circuit current for 10 cycles, for an unloaded alternator, to the terminals of which a sudden 3 phase symmetrical short circuit is applied. Explain briefly the different periods in the waveform and the respective currents. (3)
- 8 What material is used for the rotor of a hysteresis motor? (2)
- 9 Draw the torque speed characteristic of a single phase induction motor, running on main winding only. (3)
- 10 Define slip for a linear induction motor. (2)

PART – B (50 Marks)

- 11 (a) Derive the formulae for finding the breadth factor and coil span factor for the fundamental component of induced emf. (5)
(b) Find the distribution factor for a 36 slot, 4 pole single layer 3 phase winding. (5)
- 12 A 3 Phase, star connected, 1000 kVa, 11,000 v alternator has rated current of 52.5A. The effective resistance of the winding per phase is 0.45Ω . The O.C and S.C. tests on this machine gave the following results.
O.C. test: Field current = 12.5A, voltage between lines = 422 volts.
S.C. test: Field current = 12.5A, line current = 52.5A
Find the full load voltage regulation at (a) 0.8 p.f. lagging and (b) 0.8 p.f. leading (10)
- 13 (a) What are the starting methods of a synchronous motor? Describe in detail. (6)
(b) With suitable diagrams, explain how a synchronous condenser is used in a power system. (4)

- 14 A 100 MVA, 22 kV, 50 Hz synchronous generator is operating open circuited and is excited to give rated terminal voltage. A 3 phase symmetrical short circuit is applied at its terminals.
Ignore the dc and double frequency components of current and find
(a) Initial current
(b) Current at the end of two cycles and
(c) Current at the end of 10S. (10)
- 15 Obtain the equivalent circuit of a single phase induction motor running on its main winding only. Also derive the equations giving the gross mechanical power. (10)
- 16 Write short notes on:
a) Switched reluctance motor
b) Transient stability of synchronous machine connected to infinite bus (10)
- 17 Write short notes on: (10)
a) AC series motor
b) Shaded pole motor

FACULTY OF ENGINEERING

B.E. 3/4 (Inst.) II – Semester (Main) Examination, May / June 2015

Subject: Process Control

Time: 3 Hours

Max.Marks: 75

Note: Answer all questions from Part A. Answer any five questions from Part B.

PART – A (25 Marks)

- 1 With a block diagram explain final control.
- 2 Mention a few electrical control elements.
- 3 With circuit diagram explain relay controller.
- 4 Draw basic structure of PLC explain the important elements briefly.
- 5 A temperature controller has a range of 300 to 440 and a set point of 384. find the percent of span error when the temperature is 379.
- 6 Explain two position mode controller with an example.
- 7 Describe pneumatic valve positioner.
- 8 Explain thermal process with an example.
- 9 Define velocity error.
- 10 Explain the operation of solenoid valve.

PART – B (50 Marks)

- 11 a) With a schematic diagram explain current to voltage converter using op.amp.
b) Describe flapper nozzle system used for pressure control.
- 12 a) Give examples of electrical, pneumatic actuators briefly.
b) Describe discrete state process control with block diagram.
- 13 a) Explain ladder diagram with an example.
b) With a block diagram explain liquid level control system.
- 14 a) Explain PID controller with analytic expression.
b) With an example explain PLC programming.
- 15 a) Explain Ziegler Nichols method for adjustment.
b) Describe single speed control with expression.
- 16 a) Explain PLC operation with diagram.
b) With schematic diagram explain three position controller.
- 17 Write notes on the following:
 - a) Elements of process dynamics
 - b) Hydraulic actuator
 - c) Flow process.

FACULTY OF ENGINEERING

B.E. 3/4 (ECE) II-Semester (Main) Examination, May / June 2015

Subject : Digital Signal Processing

Time : 3 Hours

Max. Marks: 75

Note: Answer all questions of Part - A and answer any five questions from Part-B.**PART – A (25 Marks)**

- 1 Establish the relation between DFT and z-transform.
- 2 Find the circular convolution $x(n)=\{1, 2, 3\}$ $h(n)=\{-1, -2\}$.
- 3 Calculate the number of multiplications needed in the calculation of DFT and FFT with 64-point sequence.
- 4 Differentiate between bilinear transformation and impulse invariant transformation techniques.
- 5 Differentiate between FIR and IIR filters.
- 6 Obtain impulse response of digital filter corresponding to an analog filter with impulse response $h_a(t)=0.5 e^{-2t}$, with a sampling rate $T_s=1$.
- 7 Find the DFT of the sequence $x(n)=\{1,0,0,1\}$ using DIF algorithm.
- 8 What is prewarping effect?
- 9 What is Decimation? When it is performed?
- 10 Write any three applications of multirate signal processing.

PART – B (50 Marks)

- 11 Determine the 8-point DFT of the sequence $x(n)=\{1,1,1,1,1,1,0,0\}$.
- 12 (a) Find DTFT of unit step sequence.
(b) List out the five properties of DTFT.
- 13 Find the DFT of the sequence $x(n)=\{1, 2, 3, 4, 4, 2, 3, 1\}$ using DIT algorithm.
- 14 Design a lowpass filter with passband gain of unity, cutoff frequency of 1000 Hz and working at a sampling frequency of 5KHz the length of the impulse response is 7 using rectangular window.
- 15 Design a digital bandpass Butterworth filter with the following specifications using BLT technique.
Sampling frequency $f = 8$ KHZ
 $\alpha_p = 2$ dB in the passband $800 \leq f \leq 1000$ Hz
 $\alpha_s = 20$ dB in the stop band $0 \leq f \leq 400$ Hz and $2000 \leq f \leq \alpha$
- 16 (a) How do you change the sampling rate by arbitrary factor?
(b) Explain the interpolation process. How it is different from Decimation?
- 17 (a) Explain various addressing modes of TMS320C54 XX processor.
(b) Draw the functional diagrams of TMS 320C 54 XX processor.

FACULTY OF ENGINEERING**B.E. 3/4 (Mech.) II-Semester (Main) Examination, May / June 2015****Subject: Metal Cutting and Machine Tool Engineering****Time: 3 Hours****Max. Marks : 75****Note: Answer all questions of Part - A and answer any five questions from Part-B.****PART – A (25 Marks)**

- 1 List desirable properties of Cutting Tool material.
- 2 Indicate heat generation zones in an orthogonal metal cutting process.
- 3 Mention types of chips formed during machining of ductile and brittle materials and show their sketches.
- 4 What is machinability Index? How does it helpful to the machinist?
- 5 Distinguish between up milling and down milling.
- 6 Sketch the quick return mechanism used in shaper indicate various parts on it.
- 7 How a grinding wheel is specified?
- 8 Where do you use thread chasers?
- 9 Briefly explain the working principle of LBM.
- 10 State the advantages of jigs and fixtures.

PART – B (50 Marks)

- 11 (a) Explain single point cutting tool nomenclature by ORS. (5)
(b) Mild steel is being machined at a cutting speed of 300m/min with a tool rake angle 8° . The width of cut and uncut thickness are 2mm and 0.2mm, respectively. If the coefficient of friction between tool and the chip is 0.5 and shear stress of the work material is 400 N/mm^2 , determine (i) shear angle (ii) the cutting and thrust components of the machining force. (5)
- 12 (a) Explain Economics of machining for maximum production. (5)
(b) Explain types of wear and what are the variables effecting tool wear? (5)
- 13 (a) List out various operations can be performed on lathe and show their sketches. (5)
(b) Index for 63 divisions for milling machining. (5)
- 14 (a) Explain Gear hobbing with help of neat sketch. (5)
(b) Explain any two super finishing operations. (5)
- 15 (a) Explain Box jig and Indexing jig with help of sketches. (5)
(b) Explain the working principles of AJM mention its applications and MRR. (5)
- 16 (a) Mention any five cutting tool materials and their applications. (5)
(b) Distinguish between planer and shaper. (5)
- 17 Write short notes on : (10)
(a) Taylor's Tool like
(b) Bonds in grinding wheel
(c) EDM

FACULTY OF ENGINEERING**B.E. 3/4 (Prod.) II-Semester (Main) Examination, May / June 2015****Subject: Metal Casting & Welding****Time: 3 Hours****Max. Marks : 75****Note: Answer all questions of Part - A and answer any five questions from Part-B.****PART- A (25 Marks)**

- 1 What are the advantages of directional solidification? (3)
- 2 What are the functions of cores in casting process? (2)
- 3 State the causes and remedies of the defects 'blow holes' and 'cold shuts'. (3)
- 4 Enlist the advantages and limitations of shell moulding. (2)
- 5 Briefly explain the principle of oxy-acetylene gas welding. (3)
- 6 What are the applications of EBW process? (2)
- 7 What is the principle of resistance welding? (2)
- 8 What is the major difficulty of stainless steel welding? (3)
- 9 How cruciform test is conducted on weld joints? (3)
- 10 Briefly discuss the principle of blow moulding. (2)

PART- B (50 Marks)

- 11 (a) What is a pattern allowance? Explain the various types of pattern allowances. (5)
(b) Explain the principle and operation of Cupola with help of a neat sketch. (5)
- 12 (a) Explain the principle of true centrifugal casting process. State applications and limitations. (5)
(b) Discuss the hot chamber die casting process with aid of a neat sketch. (5)
- 13 (a) Explain the principle of explosive welding with help of neat sketch. List various types of explosives used. (5)
(b) Explain GTAW process with a neat sketch. Give its applications and advantages. (5)
- 14 (a) Compare the welding aspects of low carbon steels and stainless steels. (5)
(b) Explain the weldability of Aluminium and Al-alloys. (5)
- 15 (a) Explain the testing procedure of ring weldability test. Give its limitations and applications. (5)
(b) Discuss the working principle of Injection moulding process with help of neat sketch. State its applications and advantages. (5)
- 16 (a) Differentiate between soldering and brazing in terms of principle, application and limitations. (5)
(b) Explain the machine moulding techniques with aid of neat sketches. (5)
- 17 Write short notes on any three of the following. (10)
 - (a) Thermit welding
 - (a) Carbon equivalent test
 - (b) Laser beam welding
 - (c) Co₂ casting process

FACULTY OF ENGINEERING

B.E. 3/4 (Automobile Engg.) II – Semester (Main) Examination, May/June 2015

Subject : Performance and Testing of Automotive Vehicles

Time : 3 hours

Max. Marks : 75

Note: Answer all questions from Part-A. Answer any FIVE questions from Part-B.

PART – A (10 x 2.5 = 25 Marks)

- 1 Explain temperature and humidity effect on power output.
- 2 Explain aerodynamic Lift force and Drag force.
- 3 Write the classification of clutches.
- 4 Draw a neat sketch of epicyclic gear boxes.
- 5 How do you ensure safety of the vehicle? Justify with your answer.
- 6 Will traffic conditions and load effects the fuel economy? How?
- 7 Write the characteristics of automotive brakes.
- 8 Draw a neat sketch of radius bar.
- 9 Explain how the steering is to be tested.
- 10 What are the main parameters of the vehicle which are need to be observed during Road and Track testing?

PART – B (50 Marks)

- | | |
|---|--------|
| 11 Explain briefly the effects of front and rear end geometry on drag coefficients with neat sketches. | 10 |
| 12 a) Describe the construction and working of constant mesh gear box.
b) How will you find the total gear ratio from engine to the rear wheels? | 6
4 |
| 13 a) Explain engine rating and explain RAC, SAE, OIN rating.
b) Explain scavenge efficiency and thermal efficiency. | 5
5 |
| 14 Draw the pack and pinion steering assembly and explain the principle of operation. | 10 |
| 15 Explain the mechanics of hydraulic single-line braking system with the help of neat sketch. | 10 |
| 16 Explain the following :
a) Vehicle testing on chassis dynamometer
b) Engine testing – noise, vibration, emission power and fuel consumption. | 4
6 |
| 17 a) What is the difference between the traction and tractive effort?
b) Draw and explain Torsion bar, and Damper. | 5
5 |

FACULTY OF ENGINEERING**BE 3/4 (CSE) II Sem.(Main) Examination, May / June 2015****Subject: Principles of Programming Languages****Time: 3 Hours****Max. Marks: 75****Note: Answer All Questions from Part – A, & Any Five Questions from Part – B****PART – A (25 Marks)**

1. What is meant by programming environment? List out some of the tools that support the work of a compiler in programming environment. [2]
2. Differentiate between machine language and assembly language. [2]
3. What are pragmas? [2]
4. What is a static chain? What is it used for? [2]
5. Explain the difference between a declaration and a definition. Why is the distinction important? [3]
6. What is meant by limited and unlimited extent of objects in a local scope? [3]
7. Differentiate between type equivalence, type compatibility and type inference. [3]
8. How are break points different from watch points? [2]
9. Explain slicing with respect to arrays. [3]
10. Explain higher order functions with an example. [3]

PART – B (50 Marks)

11. a) What is an object closure? What is it used for? How is it implemented? [5]
b) Discuss about static and dynamic binding. [5]
12. a) What is internal and external fragmentation? Explain how to overcome them in detail? [5]
b) Explain selection and iteration control structures with examples. [5]
13. a) Explain in brief about generic subroutines. And explain how it differs from macros. [5]
b) What is an event? Discuss in brief how events are implemented in programming languages. [5]
14. a) Explain the relationship between dynamic method binding and polymorphism. [5]
b) What is busy – waiting? [5]
15. a) Discuss briefly about Scheme. [5]
b) Discuss briefly various features of logic programming languages. [5]
16. a) What is sequential consistency? Explain why it is difficult to implement it. [5]
b) Explain various parameter passing techniques. [5]
17. Write short notes on: [10]
a) Execution order
b) Co routines

FACULTY OF INFORMATICS

B.E. 3/4 (IT) II – Semester (Main) Examination, May / June 2015

Subject : Design and Analysis of Algorithms

Time : 3 hours

Max. Marks : 75

Note: Answer all questions from Part-A. Answer any FIVE questions from Part-B.**PART – A (25 Marks)**

- | | | |
|----|--|---|
| 1 | What are Dictionaries? Give an example. | 2 |
| 2 | Describe in brief divide and conquer technique. | 3 |
| 3 | Explain Asymptotic notations. | 3 |
| 4 | Differentiate between 0/1 Knapsack problem and Knapsack problem. | 3 |
| 5 | State the principal of optimality. | 2 |
| 6 | Define articulation point in a connected graph. | 2 |
| 7 | What are NP complete problems? | 3 |
| 8 | Differentiate between multi stage graph and graph. | 3 |
| 9 | What is Hamiltonian cycle? | 2 |
| 10 | Define the chromatic number of a graph. | 2 |

PART – B (50 Marks)

- | | | |
|----|---|-------|
| 11 | Consider the array (40, 80, 35, 90, 45, 50, 70) | |
| | a) Derive the MAX heap | |
| | b) Write the algorithm for inserting an element in the MAX heap and find its complexity. | |
| | c) Show the steps for removing the element 80 from the MAX heap. | 3+4+3 |
| 12 | a) Write a general algorithm for greedy method. | |
| | b) Sort the array {17, 28, 31, 35, 65, 25, 42, 86, 45, 52} using Quick Sort. Show each step. | 4+6 |
| 13 | a) Write Kruskal's algorithm to find the minimum cost spanning tree. Explain with an example. | |
| | b) Differentiate between greedy subset paradigm and ordering paradigm. State an example in each case. | 6+4 |
| 14 | a) Explain the backtracking technique. | |
| | b) Explain the traveling salesperson problem and write an algorithm using branch and bound. | 4+6 |
| 15 | a) What are Non-deterministic algorithms? Write its functions. | |
| | b) Explain job sequencing problem with an example. | 5+5 |

..2..

16 Find the shortest path from S to T for the multistage graph seen in below figure using dynamic programming using forward approach.

10

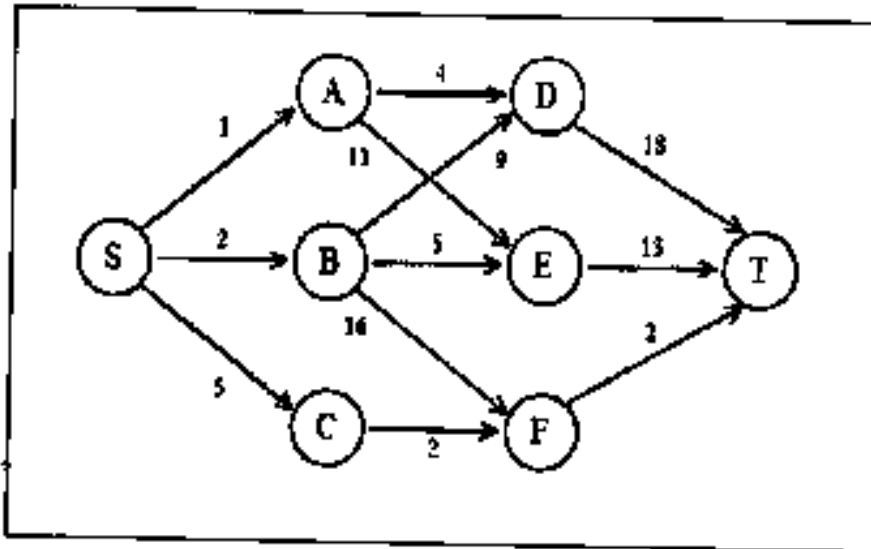

17 Write short notes on :

- Cook's theorem
- Branch and Bound

5
5

OU - 1607