

# Module 5

## DC to AC Converters

# Lesson 39

## Current Source Inverter

## Instructional Objectives

Study of the following:

- The circuit for single-phase Current Source Inverter (CSI) using thyristors
- Auto-Sequential Commutated mode of operation for 1-ph. Inverter (ASCI), with waveforms
- Three-phase Current Source Inverter (CSI) – circuit and operation, with waveforms

## Introduction

In the previous six (5.1-5.6) lessons in this module, the circuit and operation of single-phase and three-phase Voltage Source Inverters (VSI), with waveforms, were described in detail. Also, the presence of harmonics in voltage waveforms, along with its reduction mainly by Pulse Width Modulation (PWM) techniques, was presented. Presently, mainly self-commutated switching devices, like say transistors, are used in the above circuits, replacing thyristors, with bulky commutation circuits needed to turn them OFF, these being force-commutated ones. In the last two (5.7-5.8) lessons in this module, the circuit and operation of different types of single-phase and three-phase Current Source Inverters (CSI), with waveforms, will be described in detail. The device used here is thyristor. In this lesson (5.7), initially, the circuit of single-phase CSI will be presented. The Auto-Sequential Commutated mode of operation for this Inverter (ASCI), using thyristors, will be discussed in detail, with waveforms. Then, the circuit and operation of three-phase CSI, along with relevant waveforms, will be presented. Finally, the advantages and disadvantages of CSI over VSI, in brief, are described

For the VSI, as the full form denotes, the output voltage is constant, with the output current changing with the load – type, and/or the values of the components. But in the CSI, the current is nearly constant. The voltage changes here, as the load is changed. In an Induction motor, the developed torque changes with the change in the load torque, the speed being constant, with no acceleration/deceleration. The input current in the motor also changes, with the input voltage being constant. So, the CSI, where current, but not the voltage, is the main point of interest, is used to drive such motors, with the load torque changing.

**Keywords:** Single-phase and Three-phase Current Source Inverter (CSI), ASCI mode of operation, CSI using thyristors

## Single-phase Current Source Inverter

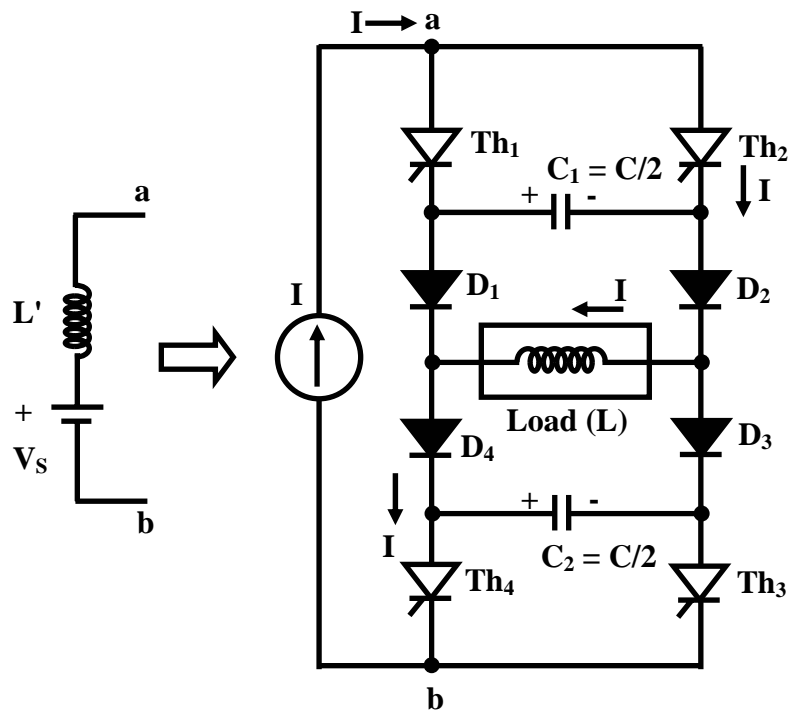

**Fig. 39.1: Single phase current source inverter (CSI) of ASCI type.**

The circuit of a Single-phase Current Source Inverter (CSI) is shown in Fig. 39.1. The type of operation is termed as Auto-Sequential Commutated Inverter (ASCI). A constant current source is assumed here, which may be realized by using an inductance of suitable value, which must be high, in series with the current limited dc voltage source. The thyristor pairs,  $Th_1$  &  $Th_3$ , and  $Th_2$  &  $Th_4$ , are alternatively turned ON to obtain a nearly square wave current waveform. Two commutating capacitors –  $C_1$  in the upper half, and  $C_2$  in the lower half, are used. Four diodes,  $D_1$ – $D_4$  are connected in series with each thyristor to prevent the commutating capacitors from discharging into the load. The output frequency of the inverter is controlled in the usual way, i.e., by varying the half time period,  $(T/2)$ , at which the thyristors in pair are triggered by pulses being fed to the respective gates by the control circuit, to turn them ON, as can be observed from the waveforms (Fig. 39.2). The inductance ( $L$ ) is taken as the load in this case, the reason(s) for which need not be stated, being well known. The operation is explained by two modes.

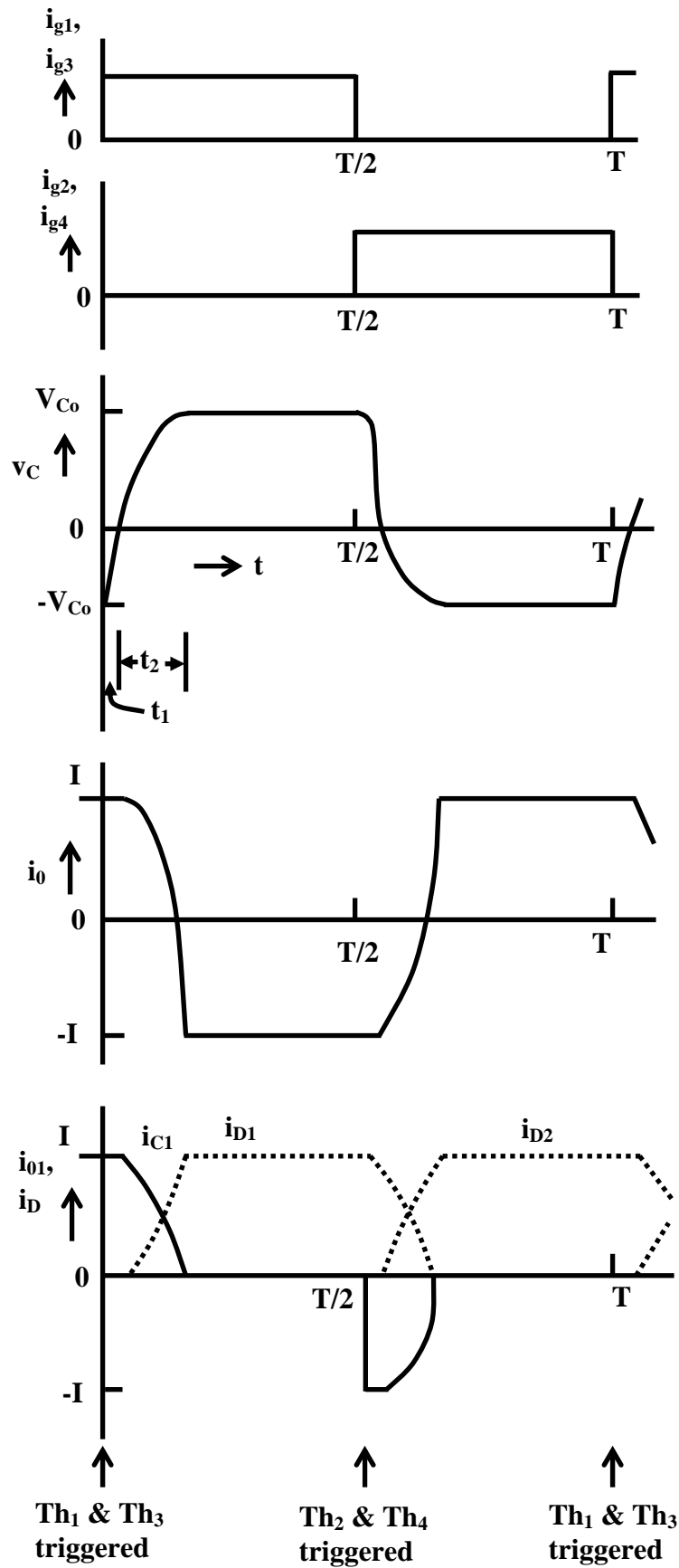
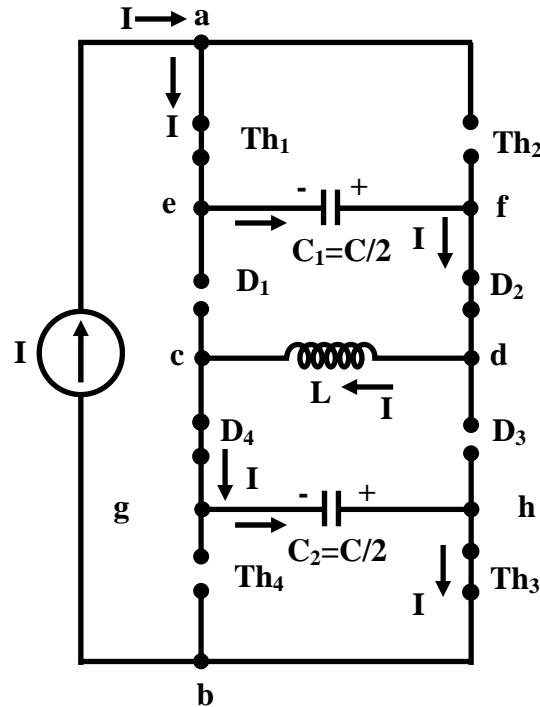

Fig. 39.2: Voltage and current waveforms

**Mode I:** The circuit for this mode is shown in Fig. 39.3. The following are the assumptions. Starting from the instant,  $t = 0^-$ , the thyristor pair, Th<sub>2</sub> & Th<sub>4</sub>, is conducting (ON), and the current (I) flows through the path, Th<sub>2</sub>, D<sub>2</sub>, load (L), D<sub>4</sub>, Th<sub>4</sub>, and source, I. The commutating capacitors are initially charged equally with the polarity as given, i.e.,  $v_{C1} = v_{C2} = -V_{C0}$ . This means that both capacitors have right hand plate positive and left hand plate negative. If two capacitors are not charged initially, they have to be pre-charged.



**Fig. 39.3: Mode I (1 phase CSI)**

At time,  $t = 0$ , thyristor pair, Th<sub>1</sub> & Th<sub>3</sub>, is triggered by pulses at the gates. The conducting thyristor pair, Th<sub>2</sub> & Th<sub>4</sub>, is turned OFF by application of reverse capacitor voltages. Now, thyristor pair, Th<sub>1</sub> & Th<sub>3</sub>, conducts current (I). The current path is through Th<sub>1</sub>, C<sub>1</sub>, D<sub>2</sub>, L, D<sub>4</sub>, C<sub>2</sub>, Th<sub>3</sub>, and source, I. Both capacitors will now begin charging linearly from  $(-V_{C0})$  by the constant current, I. The diodes, D<sub>2</sub> & D<sub>4</sub>, remain reverse biased initially. The voltage,  $v_{D1}$  across D<sub>1</sub>, when it is forward biased, is obtained by going through the closed path, abcda as  $v_{D1} + V_{co} - (1/(C/2)) \cdot \int I \cdot dt = 0$ . It may be noted the voltage across load inductance, L is zero (0), as the current, I is constant. So,  $v_{D1} = -V_{co} + (2/C) \cdot \int I \cdot dt$

As the capacitor gets charged, the voltage  $v_{D1}$  across D<sub>1</sub>, increases linearly. At some time, say  $t_1$ , the reverse bias across D<sub>1</sub> becomes zero (0), the diode, D<sub>1</sub>, starts conducting. An identical equation can be formed for diode, D<sub>3</sub> also. Actually, both diodes, D<sub>1</sub> & D<sub>3</sub>, start conducting at the same instant,  $t_1$ . The time  $t_1$  for which the diodes, D<sub>1</sub> & D<sub>3</sub>, remain reverse biased is obtained by equating,  $v_{D1} = -V_{co} + ((2 \cdot I \cdot t_1)/C) = 0$ . The time is given by,  $t_1 = (C/(2 \cdot I)) \cdot V_{C0}$ . The capacitor voltages  $v_{C1} = v_{C2} = v_C$ , appear as reverse voltage across the thyristors, Th<sub>2</sub> & Th<sub>4</sub>, when the thyristors, Th<sub>1</sub> & Th<sub>3</sub>, are triggered. The value of  $v_C$  is

$v_{C1} = v_{C2} = v_C = -V_{co} + (2/C) \cdot \int I \cdot dt$ , which, if computed at  $t = t_1$ , comes out as,
   
 $v_{C1} = v_{C2} = v_C(t_1) = -V_{co} + ((2 \cdot I \cdot t_1)/C) = -V_{co} + ((2 \cdot I)/C) \cdot (C/(2 \cdot I)) \cdot V_{co} = 0$ ,
   
 using the value of  $t_1$  obtained earlier. This means that the voltages across  $C_1$  &  $C_2$ , varies linearly from  $-V_{co}$  to zero in time,  $t_1$ . Mode I ends, when  $t = t_1$ , and  $v_C = 0$ . Note that  $t_1$  is the circuit turn-off time for the thyristors.

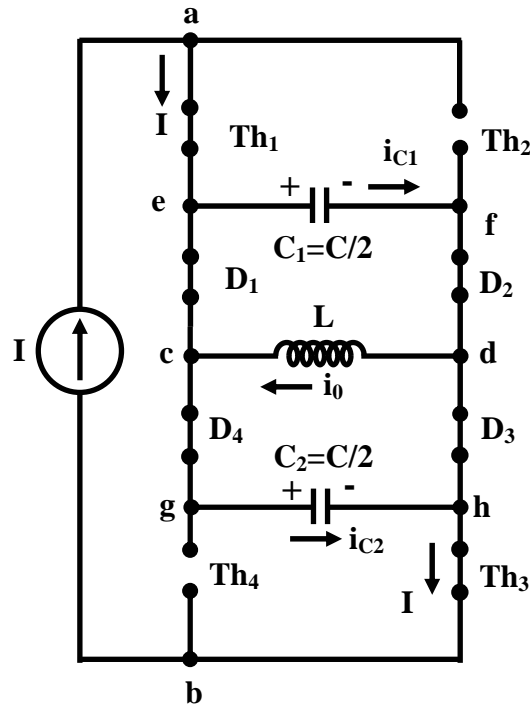

Fig. 39.4(a): Mode II (1-phase CSI)

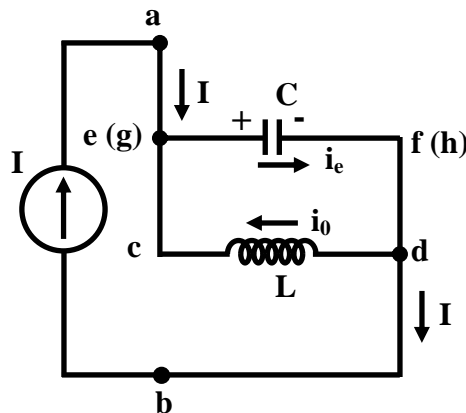

Fig. 39.4(b): Equivalent circuit for mode II

**Mode II:** The circuit for this mode is shown in Fig. 39.4a. Diodes,  $D_2$  &  $D_4$ , are already conducting, but at  $t = t_1$ , diodes,  $D_1$  &  $D_3$ , get forward biased, and start conducting. Thus, at the end of time  $t_1$ , all four diodes,  $D_1$ – $D_4$  conduct. As a result, the commutating capacitors now get connected in parallel with the load ( $L$ ). For simplicity in analysis, the circuit is redrawn as

shown in Fig. 39.4b, where the equivalent capacitor is  $C/2$ , as  $C_1 = C_2 = C$ . The equation for the current at the node is,  $I + i_0 = i_c (= i_{c1} + i_{c2})$ , where,  $i_{c1} = i_{c2} = i_c/2$ . The voltage balance equation is,

$$L \cdot \frac{di_0}{dt} = -(1/C) \cdot \int i_c \cdot dt = -(1/C) \cdot \int (I + i_0) \cdot dt$$

$$\text{or, } L \cdot \frac{d^2 i_0}{dt^2} + \frac{i_0}{C} = -\frac{I}{C} \quad \text{or, } \frac{d^2 i_0}{dt^2} + \frac{i_0}{(L \cdot C)} = -\frac{I}{(L \cdot C)}$$

$$\text{or, } (L \cdot C) \cdot \frac{d^2 i_0}{dt^2} + i_0 = -I$$

The solution of the equation is,  $i_0 = A \cdot \cos(\omega_0 \cdot t) + B \cdot \sin(\omega_0 \cdot t) + K$ ,

where, A, B & K are constants, natural frequency,

$$f_0 = 1 / ((2 \cdot \pi) \cdot \sqrt{(L \cdot C)}), \quad \omega_0 = (2 \cdot \pi) \cdot f_0 = 1 / \sqrt{(L \cdot C)}, \text{ and time period,}$$

$$T = 1 / f_0 = (2 \cdot \pi) / \omega_0 = (2 \cdot \pi) \cdot \sqrt{(L \cdot C)}.$$

The initial conditions at  $t = 0$  are,  $i_0 = I$  and  $di_0/dt = 0$ . It should be noted that the time,  $t$  is measured from the instant, the diodes,  $D_1$  &  $D_3$ , start conducting, i.e., from the instant, mode I is over. Using the initial conditions stated earlier, the current is,  $i_0 = I \cdot (2 \cdot \cos(\omega_0 \cdot t) - 1)$ . The capacitor current is  $i_c = I + i_0 = 2 \cdot I \cdot \cos(\omega_0 \cdot t)$ .

$$\text{The voltage across capacitor is, } v_c = \frac{1}{C} \cdot \int i_c \cdot dt = \left( \frac{2 \cdot I}{\omega_0 \cdot C} \right) \cdot \sin(\omega_0 \cdot t).$$

This expression can also be obtained as,

$$v_c = v_L = L \cdot (di_0/dt) = ((2 \cdot I) \cdot (\omega_0 \cdot L)) \cdot \sin(\omega_0 \cdot t), \text{ where, } \omega_0 \cdot L = 1/(\omega_0 \cdot C), \text{ as can be}$$

derived using  $\omega_0 = 1/\sqrt{(L \cdot C)}$ . So, the above expressions are same, and can be written as,

$$v_c = ((2 \cdot I) \cdot (\sqrt{L/C})) \cdot \sin(\omega_0 \cdot t), \text{ substituting the expression for } \omega_0 \text{ in any of the above}$$

expressions. So,  $i_{c1} = i_{c2} = I \cdot \cos(\omega_0 \cdot t)$ , and

$$i_{D1} = I - i_{c1} = I \cdot (\cos(\omega_0 \cdot t) - 1), \text{ in the interval } 0 < t < t_2.$$

As the current,  $i_{c1}$  tends to reverse, diode,  $D_3$  prevents its reversal. Similarly, the diode,  $D_4$  prevents the reversal of the current,  $i_{c2}$ . From the initiation of mode II, a time,  $t_2$  must elapse for the current,  $i_{c1}$  to become zero (0). The time,  $t_2$  is,

$$t_2 = (\pi/2) / \omega_0 = (\pi/2) \cdot \sqrt{(L \cdot C)} = (1/(4 \cdot f_0)) = T/4, \text{ as } (\omega_0 \cdot t_2) = (\pi/2), \text{ using,}$$

$$i_{c1} = I \cdot \cos(\omega_0 \cdot t_2) = 0. \text{ The capacitor voltage at time, } t_2 \text{ is, } v_c = ((2 \cdot I)/(\omega_0 \cdot C)) = V_{C0}. \text{ Note}$$

that this is also the maximum value. Now, the load current is,  $i_0 = I \cdot (2 - 1) = I$ . This shows that the load current has reversed from  $+I$  to  $-I$  during mode II, after time,  $t_2$ . It is also seen that the capacitor voltage changes by  $2 \cdot V_{C0}$  (from  $-V_{C0}$  to  $V_{C0}$ ) during each commutation interval. The time  $t_1$ , after substituting  $V_{C0}$ , comes out as,

$$t_1 = (C/(2 \cdot I)) \cdot V_{C0} = (C/(2 \cdot I)) \cdot ((2 \cdot I)/(\omega_0 \cdot C)) = 1/\omega_0 = \sqrt{(L \cdot C)}.$$

$$\text{The total commutation interval is, } t_c = t_1 + t_2 = (1 + (\pi/2)) / \omega_0 = (1 + (\pi/2)) \cdot \sqrt{(L \cdot C)}.$$



At the end of the process, constant current flows in the path,  $Th_1$ ,  $D_1$ , load ( $L$ ),  $D_3$ ,  $Th_3$ , and source,  $I$ . This continues till the next commutation process is initiated by the triggering of the thyristor pair,  $Th_2$  &  $Th_4$ .

The complete commutation process is summarized here. The process (mode I) starts with the triggering of the thyristor pair,  $Th_1$  &  $Th_3$ . Earlier, the thyristor pair,  $Th_2$  &  $Th_4$  were conducting. With the two commutating capacitors charged earlier with the polarity as shown (Fig. 39.3), the conducting thyristor pair,  $Th_2$  &  $Th_4$  turns off by the application of reverse voltage. Then, the voltages across the capacitors decrease to zero at time,  $t_1$  (end of mode I), as constant (source) current,  $I$  flows in the opposite direction. Mode II now starts (Fig. 39.4a), as the diodes,  $D_1$  &  $D_3$ , get forward biased, and start conducting. So, all four diodes  $D_1$ - $D_4$ , conduct, and the load inductance,  $L$  is now connected in parallel with the two commutating capacitors. The current in the load reverses to the value  $-I$ , after time,  $t_2$  (end of mode II), and the two capacitors also are charged to the same voltage in the reverse direction, the magnitude remaining same, as it was before the start of the process of commutation ( $t = 0$ ). It may be noted that the constant current,  $I$  flows in the direction as shown, a part of which flows in the two capacitors.

In the above discussion, one form of load, i.e. inductance  $L$  only, has been considered. The procedure remains nearly same, if the load consists of resistance,  $R$  only. The procedure in mode I, is same, but in mode II, the load resistance,  $R$  is connected in parallel with the two commutating capacitors. The direction of the current,  $I$  remains same, a part of which flows in the two capacitors, charging them in the reverse direction, as shown earlier. The derivation, being simple, is not included here. It is available in books on this subject.

### Three-phase Current Source Inverter

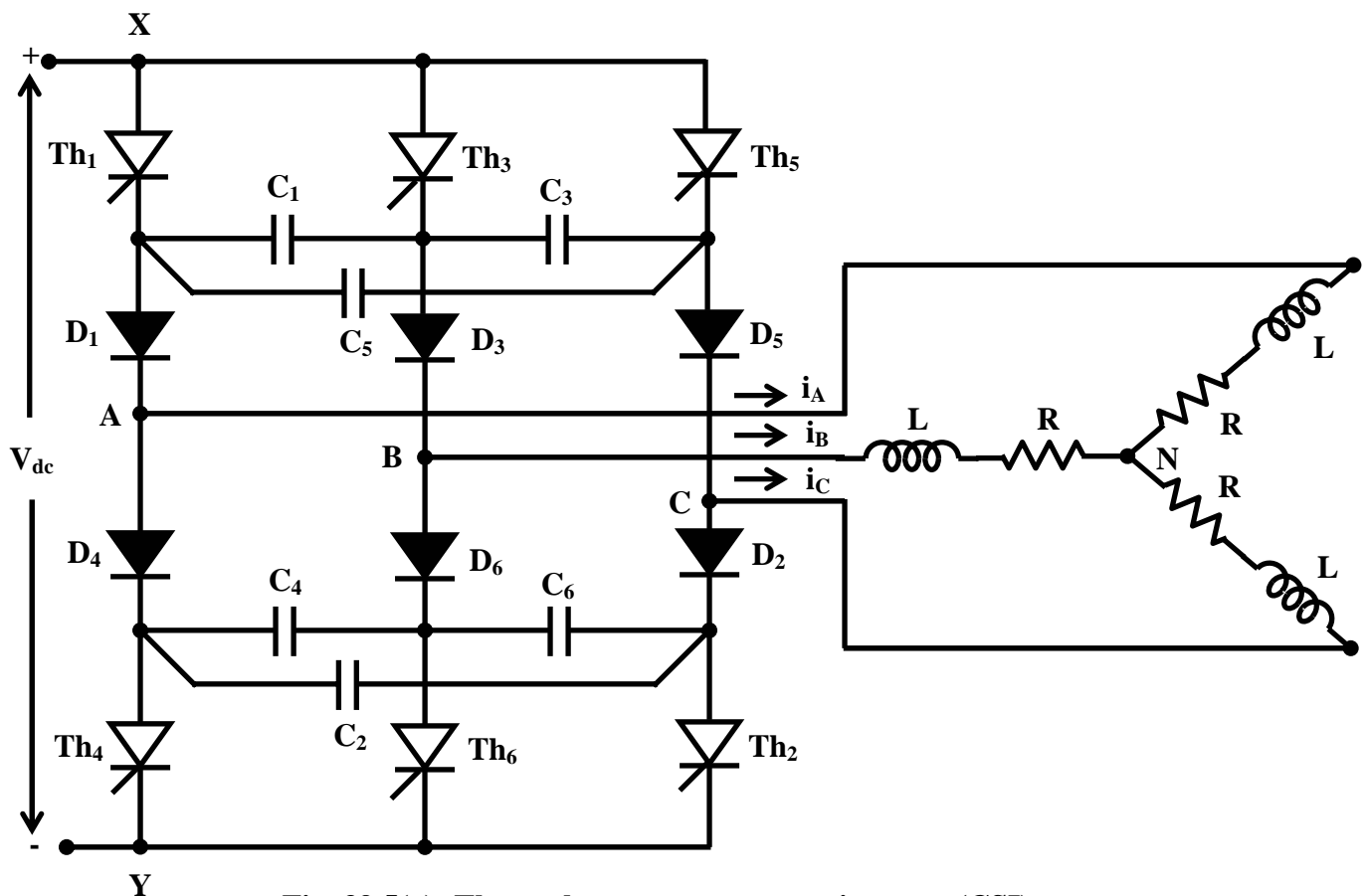

Fig. 39.5(a): Three-phase current source inverter (CSI)

The circuit of a Three-phase Current Source Inverter (CSI) is shown in Fig. 39.5a. The type of operation in this case is also same here, i.e. Auto-Sequential Commutated Inverter (ASCI). As in the circuit of a single-phase CSI, the input is also a constant current source. The output current (phase) waveforms are shown in Fig. 39.5b. In this circuit, six thyristors, two in each of three arms, are used, as in a three-phase VSI. Also, six diodes, each one in series with the respective thyristor, are needed here, as used for single-phase CSI. Six capacitors, three each in two (top and bottom) halves, are used for commutation. It may be noted that six capacitors are equal, i.e.  $C_1 = C_2 = \dots = C_6 = C$ . The diodes are needed in CSI, so as to prevent the capacitors from discharging into the load. The numbering scheme for the thyristors and diodes are same, as used in a three-phase VSI, with the thyristors being triggered in sequence as per number assigned (Fig. 39.5b).

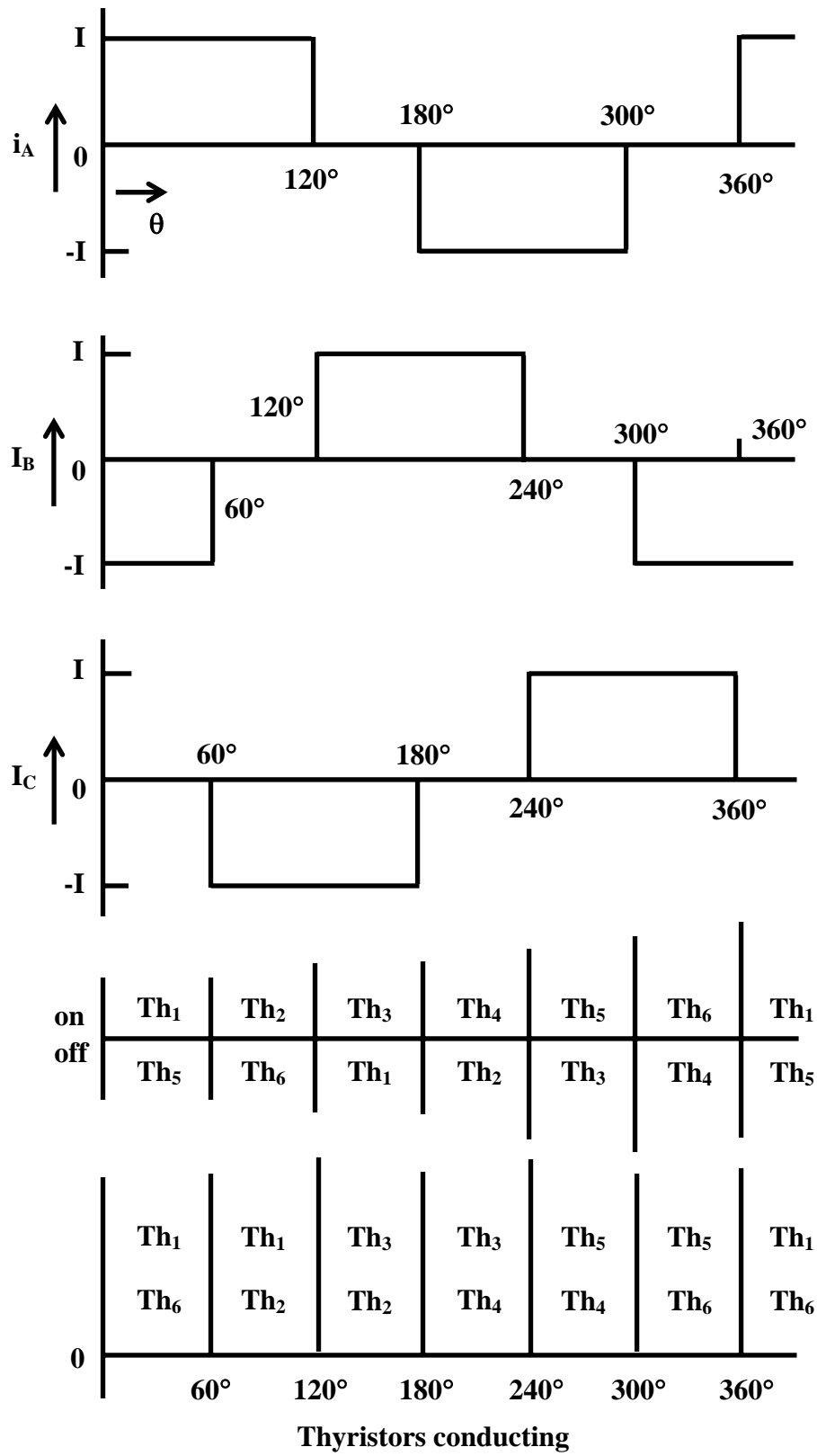
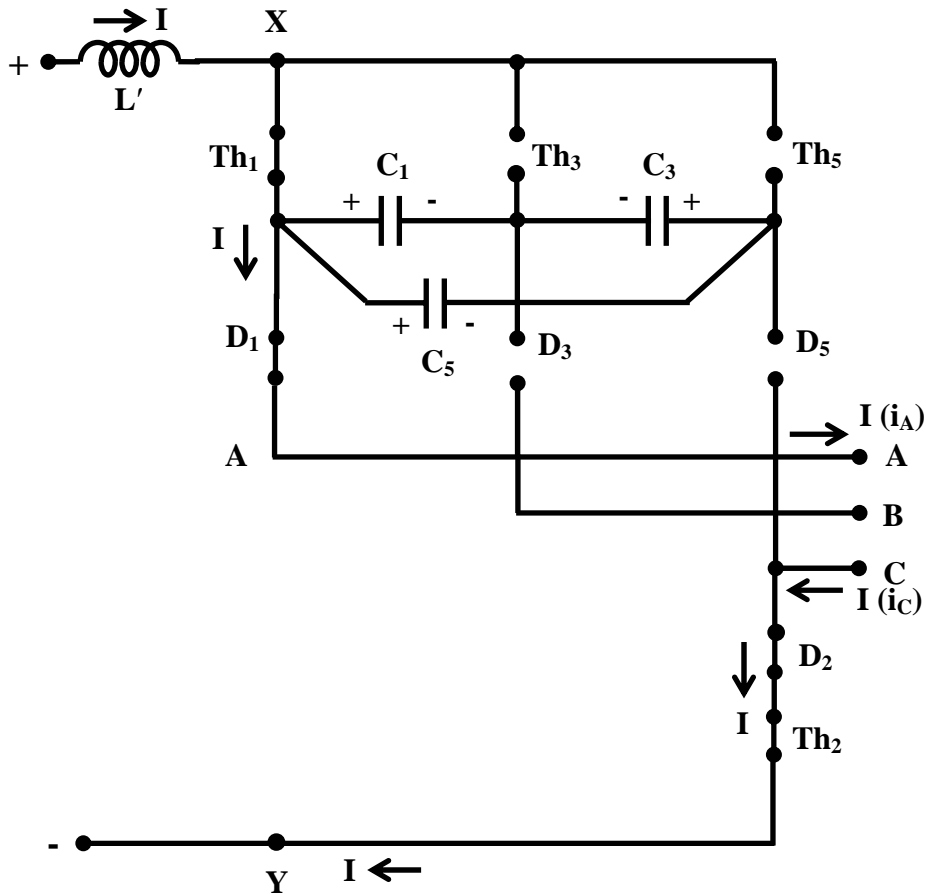

Fig. 39.5(b): Phase current waveforms

The commutation process in a three-phase CSI is described in brief. The circuit, when two thyristors,  $Th_1$  &  $Th_2$ , and the respective diodes, are conducting, is shown in Fig. 39.6a. The current is flowing in two phases, A & C. The three capacitors in the top half, are charged previously, or have to pre-charged as shown. But the capacitors in the bottom half are not shown.



**Fig. 39.6(a): Three-phase CSI with two thyristors,  $Th_1$  &  $Th_2$  conducting**

**Mode I:** The commutation process starts, when the thyristor,  $Th_3$  in the top half, is triggered, i.e. pulse is fed at its gate. Immediately after this, the conducting thyristor,  $Th_1$  turns off by the application of reverse voltage of the equivalent capacitor. Mode I (Fig. 39.6b) now starts. As the diode  $D_1$  is still conducting, the current path is via  $Th_3$ , the equivalent capacitor,  $D_1$ , and the load in phase A (only in the top half). The other part, i.e. the bottom half and the source, is not considered here, as the path there remains same. The current,  $I$  from the source now flows in the reverse direction, thus the voltage in the capacitor,  $C_1$  (and also the other two) decreases. It may be noted the equivalent capacitor is the parallel combination of the capacitor,  $C_1$  and the other part, being the series combination of the capacitors,  $C_3$  &  $C_5$  ( $C' = C/2$ ). It may be shown the its value is  $C_{eq} = C/3$ , parallel combination of  $C$  &  $C/2$ , as  $C_1 = C_3 = C_5 = C$ . Also, the current in the capacitor,  $C_1$  is  $(2/3) \cdot I$ , and the current in other two capacitors,  $C_3$  &  $C_5$  is  $I/3$ . When the voltage across the capacitor,  $C_1$  (and also the other two) decreases to zero, the mode I ends.

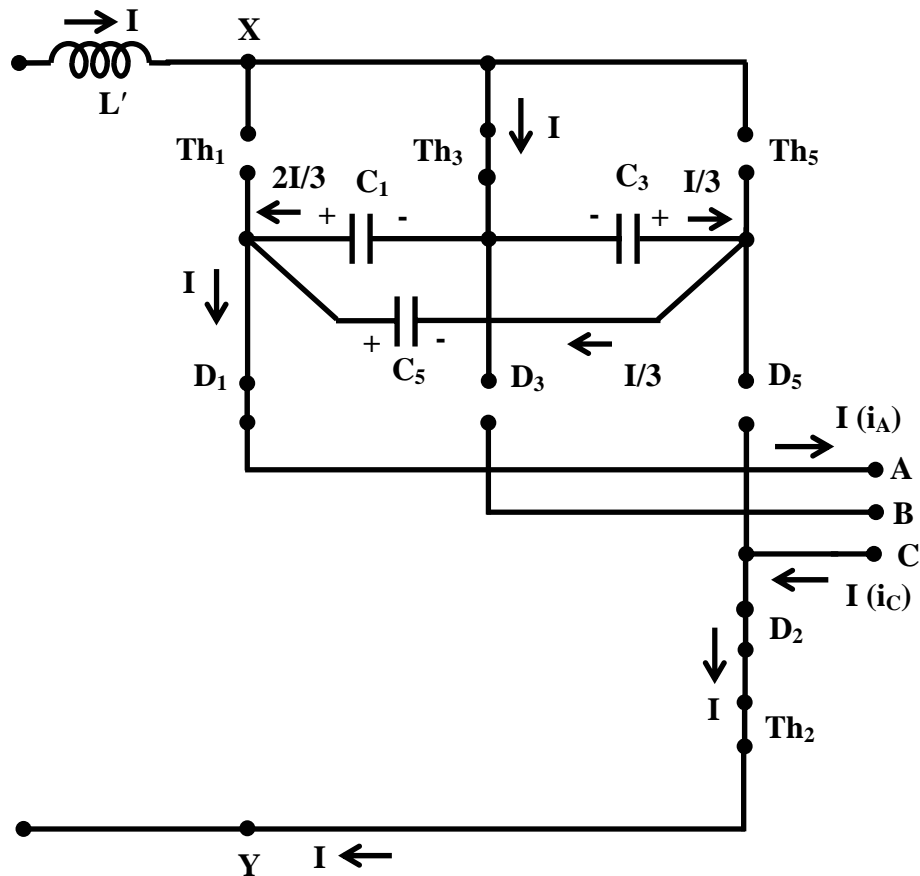

**Fig. 39.6(b): Mode I (3-phase CSI)**

**Mode II:** After the end of mode I, the voltage across the diode,  $D_3$  goes positive, as the voltage across the equivalent capacitor goes negative, assuming that initially (start of mode I) the voltage was positive. It may be noted that the current through the equivalent capacitor continues to flow in the same direction. Mode II (Fig. 39.6c) starts. Earlier, the diode,  $D_1$  was conducting. The diode,  $D_3$  now starts conducting, with the voltage across it being positive as given earlier. A circulating current path now exists between the equivalent capacitor, two conducting diodes,  $D_1$  &  $D_3$  and the load (assumed to be inductive –  $R$  &  $L$ , per phase) of the two phases,  $A$  &  $B$ , the two loads and also the two diodes being now connected in series across the equivalent capacitor. The current in this path is oscillatory, and goes to zero after some time, when the mode II ends. The diode,  $D_1$  turns off, as the current goes to zero. So, at the end of mode II, the thyristor,  $Th_3$  & the diode,  $D_3$  conduct. This process has been described in detail in the earlier section on single-phase CSI (see mode II). It may be noted that the polarity of the voltage across the equivalent capacitor (at the end of mode II) has reversed from the initial voltage (at the beginning of mode I). This is needed to turn off the outgoing (conducting) thyristor,  $Th_3$ , when the incoming thyristor,  $Th_5$  is triggered. The complete commutation process as described will be repeated. The diodes in the circuit prevent the voltage across the capacitors discharging through the load.

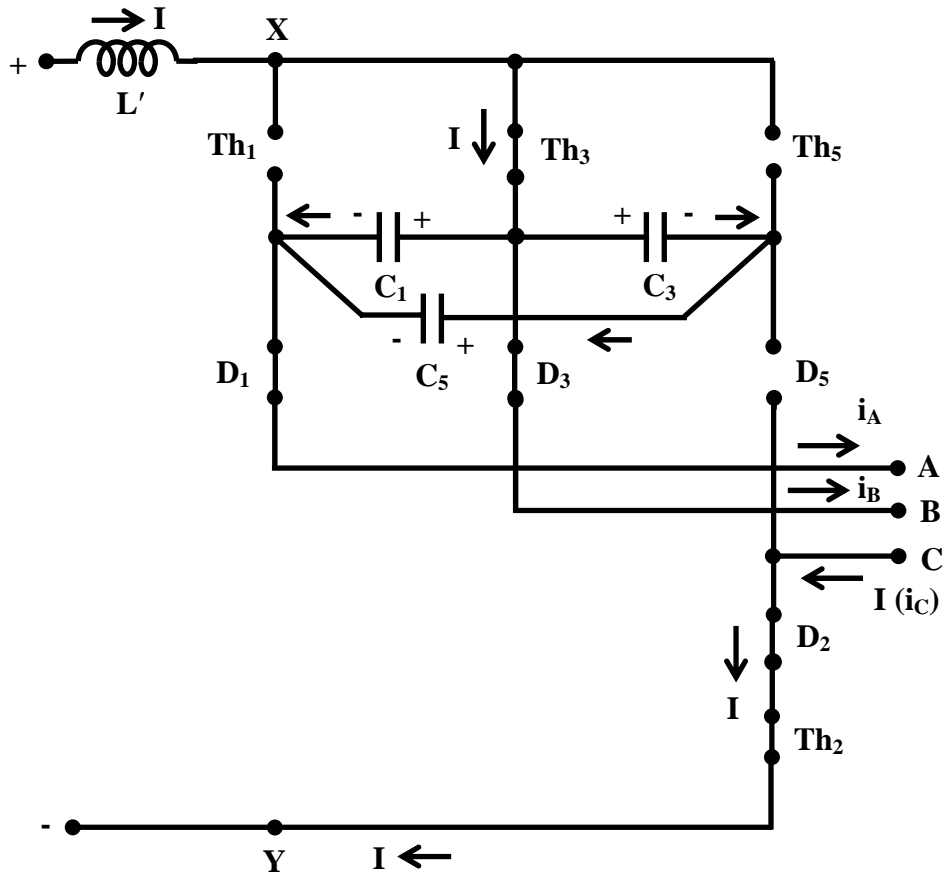

**Fig. 39.6(c): Mode II (3-phase CSI)**

The circuit is shown in Fig. 39.6d, with two thyristors,  $Th_3$  &  $Th_2$ , and the respective diodes conducting. The current now flows in two phases, B & C, at the end of the commutation process, instead of phase A at the beginning (Fig. 39.6a). It may be noted the current in the bottom half (phase C) continues to flow, and also the thyristor,  $Th_2$  & the diode,  $D_2$  remain in conduction mode. This, in brief, is the commutation process, when the thyristor,  $Th_3$  is triggered and the current is transferred to the thyristor,  $Th_3$  & the diode,  $D_3$  (phase B), from the thyristor,  $Th_1$  & the diode,  $D_1$  (phase A).

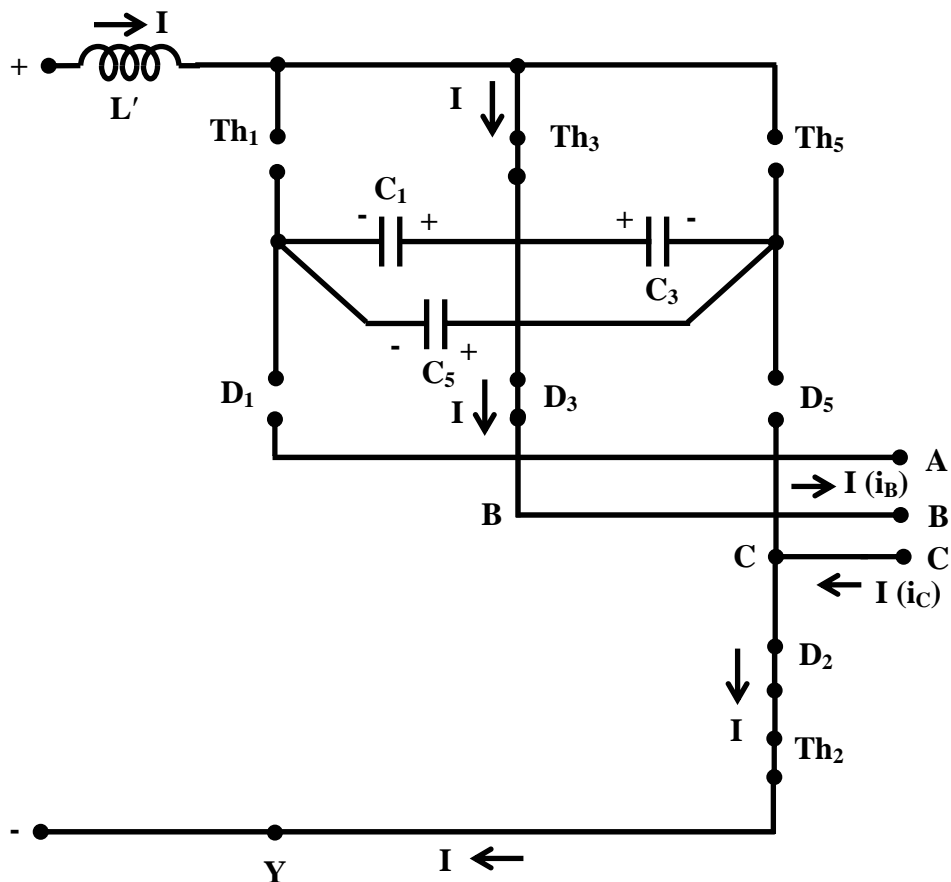

Fig. 39.6(d): Three-phase CSI with two thyristors,  $Th_3$  &  $Th_2$  conducting

## Comments

In the introductory remarks, one merit of CSI has been stated, i.e. it can be used for the speed control of ac, specially induction, motors subject to variation in load torque. In recent years, self-commutated power switching devices, such as power transistors etc., are being used in VSI, but not costly inverter-grade thyristors (having low turn-off time), along with bulky commutation circuits. These circuits also need additional diodes for feeding the reactive power back to the supply, when used with heavily inductive loads. The advantages and disadvantages of CSI vis-à-vis VSI are given.

## Advantages

1. The circuit for CSI, using only converter grade thyristor, which should have reverse blocking capability, and also able to withstand high voltage spikes during commutation, is simple.
2. An output short circuit or simultaneous conduction in an inverter arm is controlled by the 'controlled current source' used here, i.e., a current limited voltage source in series with a large inductance.
3. The converter-inverter combined configuration has inherent four-quadrant operation capability without any extra power component.

## Disadvantages

1. A minimum load at the output is required, and the commutation capability is dependant upon load current. This limits the operating frequency, and also puts a limitation on its use for UPS systems.
2. At light loads, and high frequency, these inverters have sluggish performance and stability problems.

In this lesson – the seventh one of this module, the current source inverter (CSI) vis-à-vis VSI, is introduced. The commutation process for Auto-Sequential Commutated Inverter (ASCI) mode of operation in single-phase CSI, is mainly described, along with circuit diagram and relevant waveforms, in detail. Then, the commutation process for the same mode of operation, i.e. ASCI, in three-phase CSI, is described, along with various circuit diagrams, in brief. Finally, the advantages and disadvantages of CSI over VSI, are presented. In the next lesson, eighth and last one, of this module, the load-commutated CSI, and also the Pulse Width Modulation (PWM) techniques used in CSI, will be discussed.