



Estd: 2008

# METHODIST

## COLLEGE OF ENGINEERING & TECHNOLOGY

Approved by AICTE New Delhi | Affiliated to Osmania University, Hyderabad  
Abids, Hyderabad, Telangana, 500001

DEPARTMENT OF MECHANICAL ENGINEERING

**LABORATORY MANUAL**

# **MACHINE DRAWING AND MODELLING LABORATORY**

**BE III Semester**

**For the Students admitted in AICTE Scheme**

Name: .....

Roll No: .....

Branch:.....SEM:.....

Academic Year: .....



Estd: 2008

# METHODIST

## COLLEGE OF ENGINEERING & TECHNOLOGY

Approved by AICTE New Delhi | Affiliated to Osmania University, Hyderabad  
Abids, Hyderabad, Telangana, 500001

### VISION

To produce ethical, socially conscious and innovative professionals who would contribute to sustainable technological development of the society.

### MISSION

To impart quality engineering education with latest technological developments and interdisciplinary skills to make students succeed in professional practice.

To encourage research culture among faculty and students by establishing state of art laboratories and exposing them to modern industrial and organizational practices.

To inculcate humane qualities like environmental consciousness, leadership, social values, professional ethics and engage in independent and lifelong learning for sustainable contribution to the society.



**Estd: 2008**

# **METHODIST**

## **COLLEGE OF ENGINEERING & TECHNOLOGY**

**Approved by AICTE New Delhi | Affiliated to Osmania University, Hyderabad**

**Abids, Hyderabad, Telangana, 500001**

**DEPARTMENT OF MECHANICAL ENGINEERING**

**LABORATORY MANUAL**

# **MACHINE DRAWING AND MODELLING LABORATORY (PC252ME)**

**Prepared by**

**Mr. Srikanth Rangdal, Assistant Professor. Mech. Engg.**

**Mr. Ali Ahmed, Assistant Professor. Mech. Engg.**

## **DEPARTMENT OF MECHANICAL ENGINEERING**

### **VISION**

To be a reputed centre of excellence in the field of mechanical engineering by synergizing innovative technologies and research for the progress of society.

### **MISSION**

- To impart quality education by means of state-of-the-art infrastructure.
- To involve in trainings and activities on leadership qualities and social responsibilities.
- To inculcate the habit of life-long learning, practice professional ethics and service the society.
- To establish industry-institute interaction for stakeholder development.

## DEPARTMENT OF MECHANICAL ENGINEERING

**After 3-5 years of graduation, the graduates will be able to:**

**PEO1:** Excel as engineers with technical skills, and work with complex engineering systems.

**PEO2:** Capable to be entrepreneurs, work on global issues, and contribute to industry and society through service activities and/or professional organizations.

**PEO3:** Lead and engage diverse teams with effective communication and managerial skills.

**PEO4:** Develop commitment to pursue life-long learning in the chosen profession and/or progress towards an advanced degree

## DEPARTMENT OF MECHANICAL ENGINEERING

### PROGRAM OUTCOMES

#### Engineering Graduates will be able to:

**PO1. Engineering knowledge:** Apply the basic knowledge of mathematics, science and engineering fundamentals along with the specialized knowledge of mechanical engineering to understand complex engineering problems.

**PO2. Problem analysis:** Identify, formulate, design and analyse complex mechanical engineering problems using knowledge of science and engineering.

**PO3. Design/development of solutions:** Develop solutions for complex engineering problems, design and develop system components or processes that meet the specified needs with appropriate consideration of the public health and safety, and the cultural, societal, and environmental considerations.

**PO4. Conduct investigations of complex problems:** Formulate engineering problems, conduct investigations and solve using research-based knowledge.

**PO5. Modern tool usage:** Use the modern engineering skills, techniques and tools that include IT tools necessary for mechanical engineering practice.

**PO6. The engineer and society:** Apply the contextual knowledge to assess societal, health, safety, legal and cultural issues and the consequent responsibilities relevant to the professional engineering practice.

**PO7. Environment and sustainability:** Understand the impact of the professional engineering solutions in societal and environmental contexts, and demonstrate the knowledge of, and need for sustainable development.

**PO8. Ethics:** Apply ethical principles and commit to professional ethics and responsibilities during professional practice.

**PO9. Individual and team work:** Function effectively as an individual, and as a member or leader in diverse teams, and in multidisciplinary settings.

**PO10. Communication:** Communicate effectively on complex engineering activities to various groups, ability to write effective reports and make effective presentations.

**PO11. Project management and finance:** Demonstrate and apply the knowledge to understand the management principles and financial aspects in multidisciplinary environments.

**PO12. Life-long learning:** Recognize the need for, and have the preparation and ability to engage in independent and life-long learning in the broadest context of technological change.

### PROGRAM SPECIFIC OUTCOMES

#### Mechanical Engineering Graduates will be able to:

**PSO1:** Apply the knowledge of CAD/CAM/CAE tools to analyse, design and develop the products and processes related to Mechanical Engineering.

**PSO 2:** Solve problems related to mechanical systems by applying the principles of modern manufacturing technologies.

**PSO 3:** Exhibit the knowledge and skill relevant to HVAC and IC Engines.

## **CODE OF CONDUCT**

1. Students should report to the concerned labs as per the time table schedule.
2. Students who turn up late to the labs will in no case be permitted to perform the experiment scheduled for the day.
3. After completion of the experiment, certification of the concerned staff in-charge in the observation book is necessary.
4. Staff member in-charge shall award marks based on continuous evaluation for each experiment out of maximum 15 marks and should be entered in the evaluation sheet/attendance register.
5. Students should bring a note book of about 100 pages and should enter the readings/observations into the note book while performing the experiment.
6. The record of observations along with the detailed experimental procedure of the experiment performed in the immediate last session should be submitted and certified by the staff member in-charge.
7. Not more than three students in a group are permitted to perform the experiment on a setup for conventional labs and one student in case of computer labs.
8. The components required pertaining to the experiment should be collected from stores in-charge after duly filling in the requisition form.
9. When the experiment is completed, students should disconnect the setup made by them, and should return all the components/instruments taken for the purpose.
10. Any damage of the equipment or burn-out of components will be viewed seriously either by putting penalty or by dismissing the total group of students from the lab for the semester/year.
11. Students should be present in the labs for the total scheduled duration.
12. Students are required to prepare thoroughly to perform the experiment before coming to Laboratory.

## **DO'S**

1. Leave footwear & bag outside the laboratory at their designated place.
2. Enter the system number in the register & use the system alone.
3. Report any broken plugs, exposed electrical wires or any unsafe conditions to your lecturer/laboratory staff immediately.
4. Read and understand the procedure from Lab Manual as how to carry out an activity thoroughly before coming to the laboratory.
5. Always keep anti-virus in active mode
6. Students must carry their Identity Cards & Observation Notes in the Lab.
7. Enter or Leave the lab only with the permission of the lab in charge.
8. Turn off the respective system and arrange the chairs properly before leaving the laboratory.

## **DON'TS**

1. Do not install, uninstall or alter any software on computer.
2. Do not touch electrical fittings nor connect or disconnect any plug or cable.
3. Do not plug in external drives like pen drive, external hard disk or mobile phone
4. Students are not allowed to work in the Lab without the presence of faculty or instructor.
5. Do not leave your place, misbehave or make noise while in the Lab.
6. Don't scatter around unwanted things while doing an experiment.
7. Do not eat or drink in the laboratory.



## COURSE OBJECTIVES

The objectives of this course are

1	To understand format of drawing sheet, angle of projections, isometric projections and practice on simple machine elements
2	To practice free hand sketching of machine elements
3	To understand Modelling of assembly drawings of typical machine parts.

## COURSE OUTCOMES

CO No.	Course Outcomes	PO
CO 1	Develop the skills in drafting various machine components using Auto Cad software.	1,2,5,8,9,12
CO 2	Interpret the conventions & symbols used in technical drawings into their physical meanings & vice versa	1,5,12
CO 3	Construct orthographic views of simple machine components.	1,2,5,8,9
CO 4	Demonstrate the working knowledge in solidworks to model, assemble and generate orthographic views.	1,2,5,12
CO 5	Develop 3D models, assemble and generate drawings of components using Solidworks.	1,2,5,8,9
CO 6	Observe 3D interactive CAD models and determine the Zsteps used in modelling them.	1,2,5,8,11,12

## COURSE OUTCOMES VS POs MAPPING

S. NO	PO1	PO2	PO3	PO4	PO5	PO6	PO7	PO8	PO9	PO10	PO11	PO12	PSO1	PSO2	PSO3
PC252ME.1	3	2	-	-	2	-	-	2	2	-	-	2	3	-	2
PC252ME.2	3	-	-	-	2	-	-	-	-	-	-	2	-	-	-
PC252ME.3	3	2	-	-	3	-	-	2	2	-	-	-	3	-	-
PC252ME.4	3	2	-	-	3	-	-	-	-	-	-	2	3	-	2
PC252ME.5	3	2	-	-	3	-	-	2	3	-	-	2	3	-	2
PC252ME.6	3	3	-	-	3	-	-	2	-	-	2	2	3	-	-
Avg	3.0	2.2	-	-	2.7	-	-	2.0	2.3	-	2.0	2.0	3.0	-	2.0

## LIST OF EXPERIMENTS

Exp. No.	Experiment Name	Page No.
<b>Machine Drawing (AutoCAD)</b>		
1.	Format of drawing sheet & title block,	13
2.	Conventions of drawing lines and dimensions, sectional views.	14
3.	Simple Machine Elements.	15
4.	Riveted Fastenings.	16
5.	Screwed Fastenings.	20
6.	Joints and Coupling.	22
<b>Assembly drawing (SOLIDWORKS)</b>		
7.	Stuffing Boxes	27
8.	Cross Heads	30
9.	Eccentrics	32
10.	Lathe Tool Post	35
11.	Pedestal bearing (Plummer block).	38
12.	Screw Jack	40
13.	Connecting Rod	42
14.	Rotating Center	45

**Note:** The test is for the ability of the student to read and interpret drawing. The drawing should include part list in standard format.





**PART I**  
**Machine Drawing**  
**(AutoCAD)**

**INTRODUCTION**  
**Format of Drawing Sheet & Title Block**

**Designation of sheet sizes**

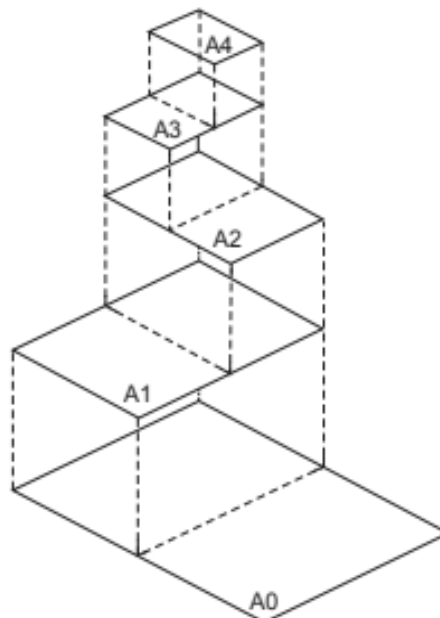
The original drawing should be made on the smallest sheet, permitting the necessary clarity and resolution. The preferred sizes according to ISO-A series (First choice) of the drawing sheets are given in Table 2.1. When sheets of greater length are needed, special elongated sizes (Second choice) are used (Table 2.2). These sizes are obtained by extending the shorter sides of the format of the ISO-A series to lengths that are multiples of the shorter sides of the chosen basic format.

**Table 2.1** Preferred drawing sheet sizes (First choice) ISO-A Series

<i>Designation</i>	<i>Dimensions (mm)</i>
A0	841 × 1189
A1	594 × 841
A2	420 × 594
A3	297 × 420
A4	210 × 297

**Table 2.2** Special elongated sizes (Second choice)

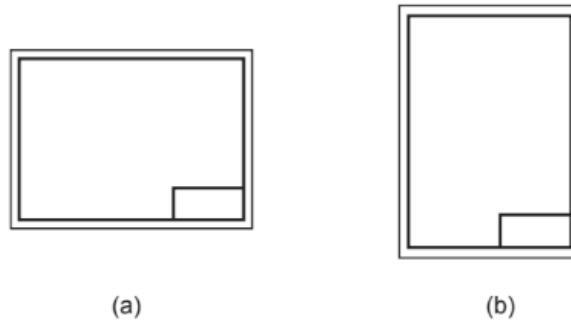
<i>Designation</i>	<i>Dimensions (mm)</i>
A3 × 3	420 × 891
A3 × 4	420 × 1188
A4 × 3	297 × 630
A4 × 4	297 × 840
A4 × 5	297 × 1050



**Fig. 2.1** Drawing sheet formats

itle Block

The title block should lie within the drawing space such that, the location of it, containing the identification of the drawing, is at the bottom right hand corner. This must be followed, both for sheets positioned horizontally or vertically (Fig. 2.2).



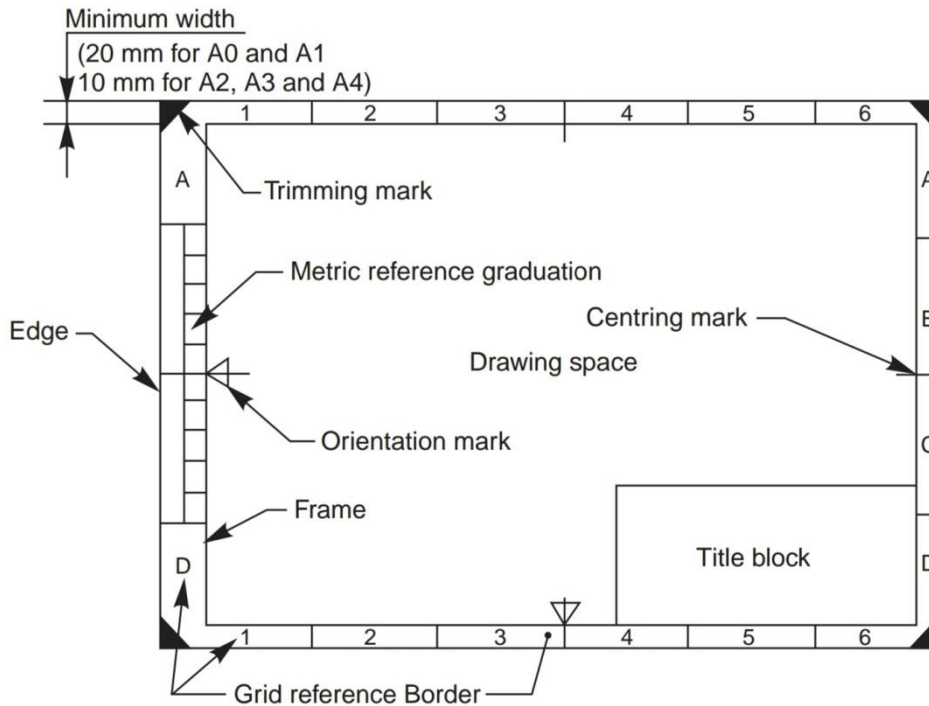
**Fig. 2.2** Location of title block

170						
65		NAME	DATE	MATERIAL	TOLERANCE	FINISH
	DRN					
	CHD					
	APPD					
	PROJECTION	LEGAL OWNER		TITLE		
	SCALE			IDENTIFICATION NUMBER		

**Fig. 2.3** Details in title block

The direction of viewing of the title block should correspond in general with that of the drawing. The title block can have a maximum length of 170 mm. Figure 2.3 shows a typical title block, providing the following information:

- i. Title of the drawing
- ii. Sheet number
- iii. Scale
- iv. Symbol, denoting the method of projection
- v. Name of the firm
- vi. Initials of staff drawn, checked and approved.



#### AutoCAD commands:

Layouts: these can be accessed from the tab at the bottom of AutoCAD window (just above command line).

- They show the drawings exactly as they'd appear in the printout (unless the printer is faulty) when the LineWeight visibility is ON.
- Absolute scale can be adjusted by using Zoom command & entering scale factor as 1XP for 1:1 & so on...
- Title bar drawn in layout space in paper mode will keep its size fixed relative to the size of sheet A4, A2 etc...
- To change paper size & other settings right click on layout name at the bottom & select "Page Setup Manager" option.

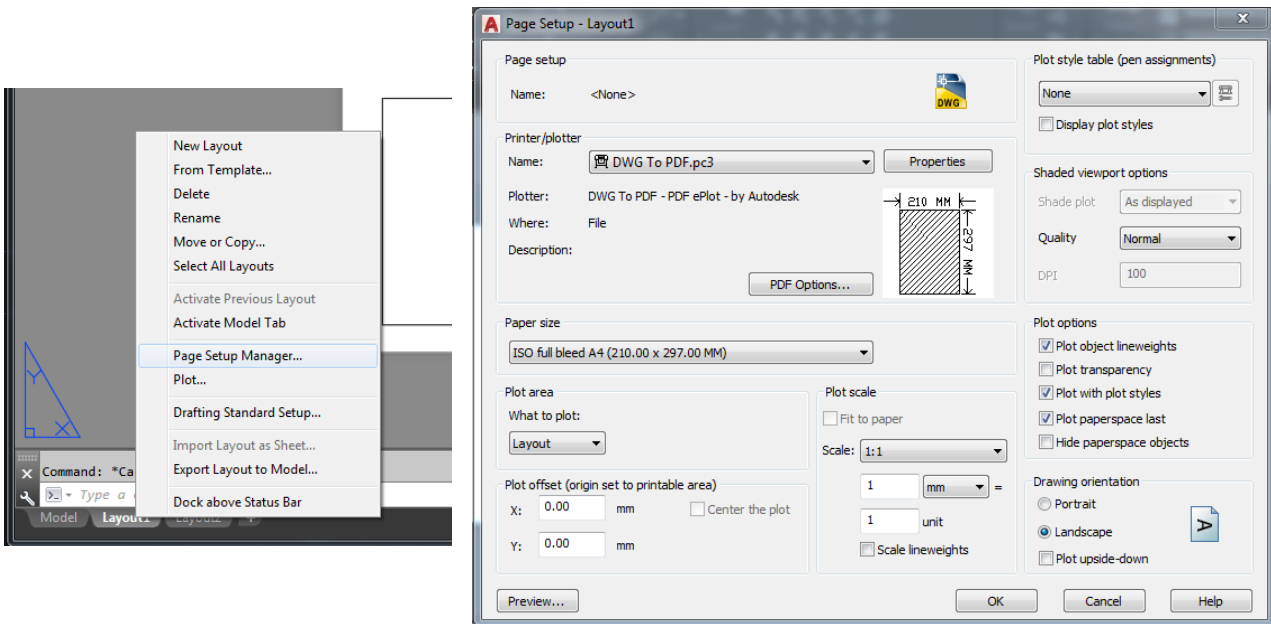
#### Task - Create an AutoCAD Template:

Templates are files which save all the settings (of dimensioning, text, linetype, color, linewidth, Blocks, layers, layouts etc...) that can speed up the drafting process of an engineer by avoiding unnecessary waste of time.

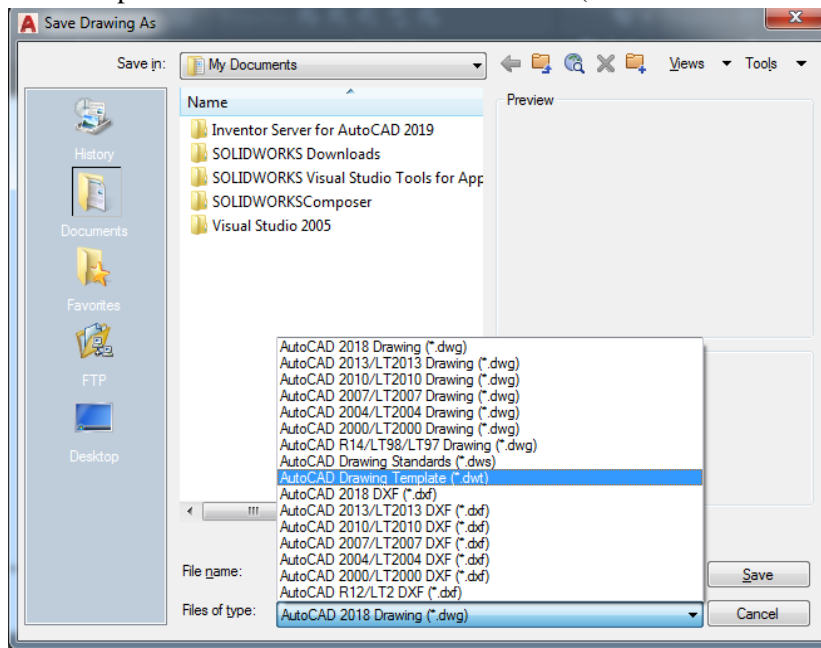
Create a template for yourself with following settings.

1. Right click on layout name & Change the Printer/plotter & paper size as shown in the image below.





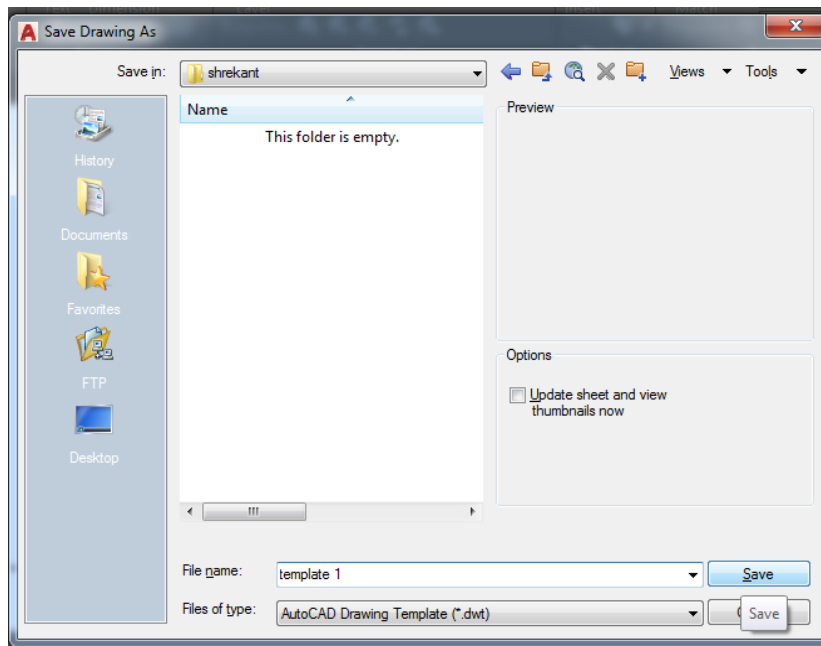
2. Change other settings like layers, colors etc... suitably as required.
3. Save the file as a template in D drive with extension of .dwt (refer to the following images).



4. The next time you want to use the template, just open it from its location using windows explorer by double clicking the template file from its location.
  - a. When you save your work it will ask you to save in a separate file with .dwg extension.

**Trick:**




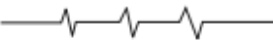





Using template avoids unnecessary wastage of time spent on adjusting the settings & loading additional objects. In the companies, the manager or team leader is given the responsibility to prepare the template based on the conventions followed by the company. This ensures uniformity in the conventions followed.



### Conventions of drawing lines and dimensions

Lines of different types and thicknesses are used for graphical representation of objects. The types of lines and their applications are shown in Table 2.4. Typical applications of different types of lines are shown in Figs. 2.5 and 2.6.

**Table 2.4** Types of lines and their applications

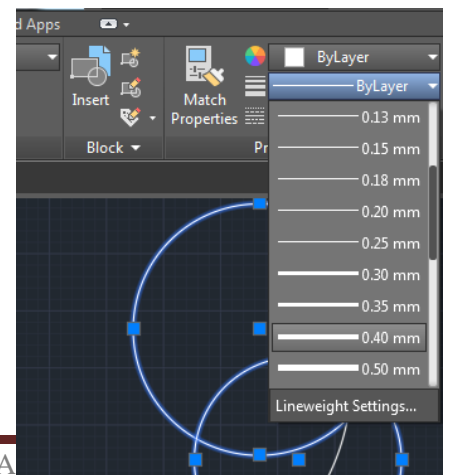
<i>Line</i>	<i>Description</i>	<i>General Applications</i>
A 	Continuous thick	A1 Visible outlines
B 	Continuous thin (straight or curved)	B1 Imaginary lines of intersection B2 Dimension lines B3 Projection lines B4 Leader lines B5 Hatching lines B6 Outlines of revolved sections in place B7 Short centre lines
C 	Continuous thin, free-hand	C1 Limits of partial or interrupted views and sections, if the limit is not a chain thin
D 	Continuous thin (straight) with zigzags	D1 Line (see Fig. 2.5)
E 	Dashed thick	E1 Hidden outlines
G 	Chain thin	G1 Centre lines G2 Lines of symmetry G3 Trajectories
H 	Chain thin, thick at ends and changes of direction	H1 Cutting planes
J 	Chain thick	J1 Indication of lines or surfaces to which a special requirement applies
K 	Chain thin, double-dashed	K1 Outlines of adjacent parts K2 Alternative and extreme positions of movable parts K3 Centroidal lines

#### AutoCAD commands:

**Line Weight (LW):** Use this command to control & adjust the visibility of thickness of lines. In model space it will just be visible relative to screen & in layout space it will be absolute as it appears on the paper.

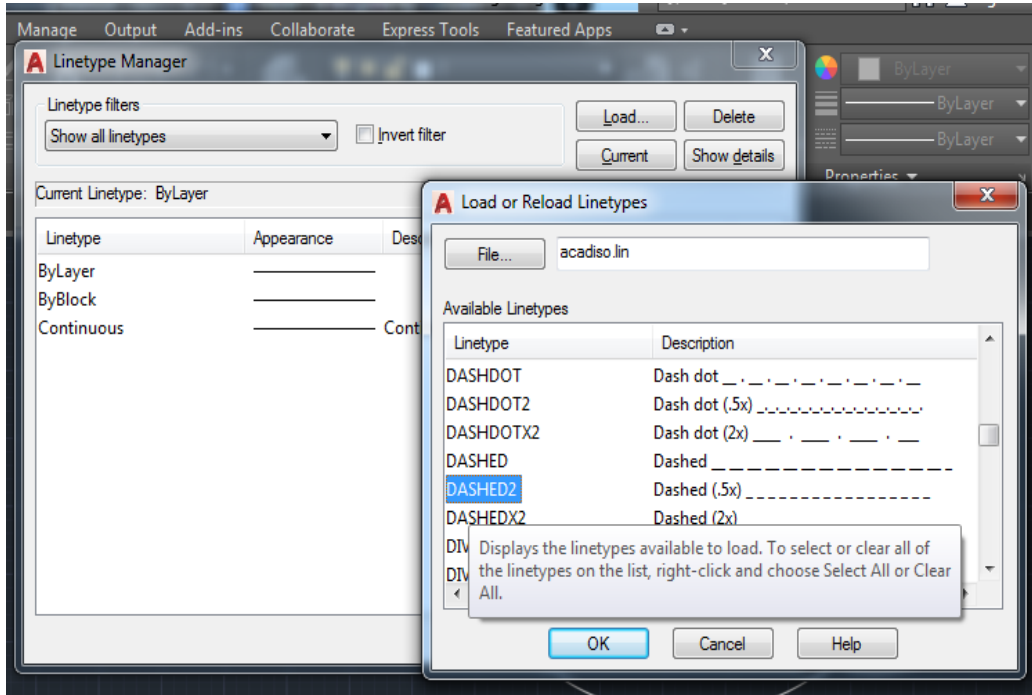
Follow below steps to change the weight of a particular object:

1. Select the objects for which lineweight needs to be changed.
2. From the properties toolbar drop list select suitable value as shown in diagram.



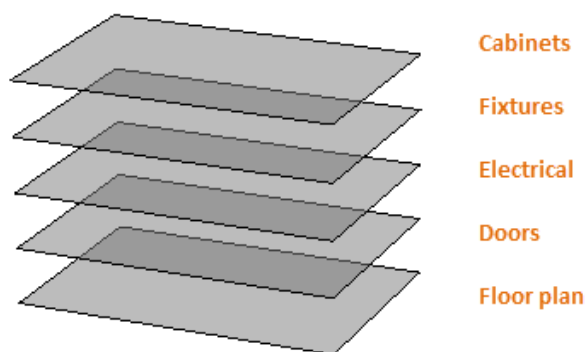
**Line Type (LT):** Use this command to control the line style of 2D objects, Ex: hidden as dotted, axes as chain dotted etc. First we need to load the Linetypes we would like to use in our file. Steps for that are as follows:

1. Press LT enter on keyboard to see loaded Linetypes.
2. Click on the **Load** button & double click whichever linetypes you want to use. They will be loaded.
3. Use the image on next page for reference.



Follow below steps to change the Line Weight of a particular object:

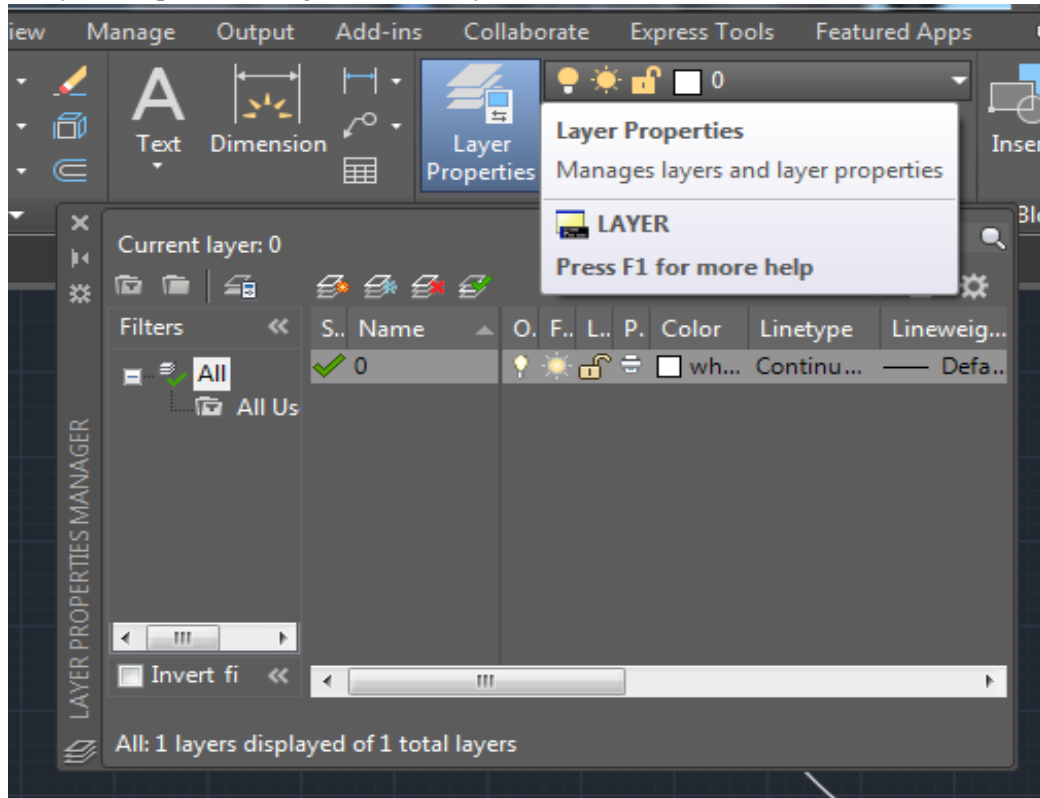
1. Select the objects for which lineweight needs to be changed.
2. From the properties toolbar drop list select suitable value as shown in diagram.



**Layers (LA):**

Layers are used to **control the visibility** of objects and to assign properties such as **Color, Line Weight** and **Line Type**. Objects on a layer normally assume the properties of that layer. However, you can override any layer property of an object. For example, if an object's color property is set to BYLAYER, the object displays the color of that layer. If the object's color is set to Red, the object displays as red, regardless of the color assigned to that layer. It is RECOMMENDED that you use Layers method:

1. In Layers Properties dialog box create layers with suitable names.



2. Change the color, Lineweight, Linetype for each layer as per requirement.
3. Objects put in a particular layer will gain all the properties assigned to that layer.
4. To move objects to a particular layer:
  - a. Select the objects to be moved.
  - b. From Layers dropdown select the layer to which you want to move the objects.
  - c. Ensure that the properties of the object are set to "ByLayer" or else the object will not
  - d. take up the properties from Layer.

**MATCH properties** command: To copy formatting of one object to others.

1. Press MA enter on keyboard.
2. Select the object with desired properties.
3. Select object you want to have the same desired properties.

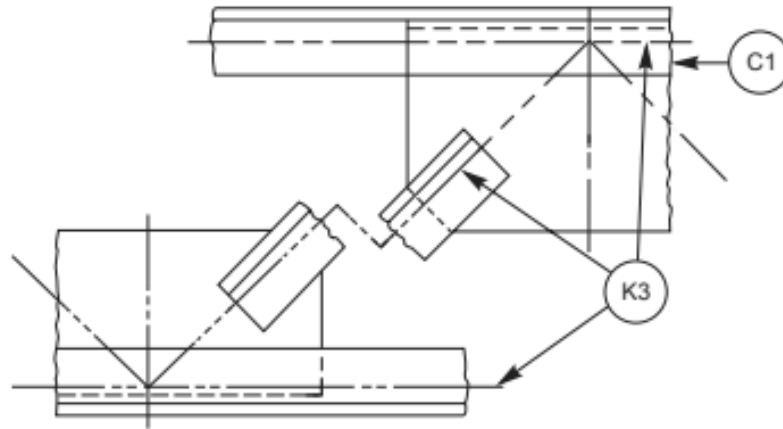


Fig. 2.6 Applications of lines

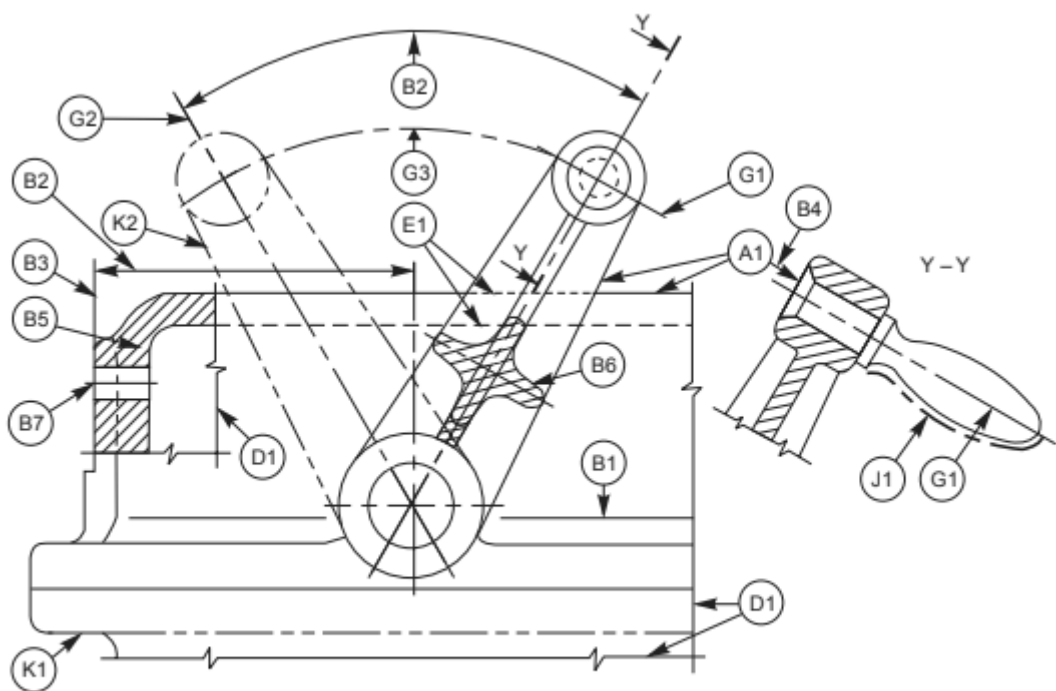


Fig. 2.5 Applications of lines

The elements of dimensioning include the projection line, dimension line, leader line, dimension line termination, the origin indication and the dimension itself. The various elements of dimensioning are shown in Figs. 2.28 and 2.29. The following are some of the principles to be adopted during execution of dimensioning:

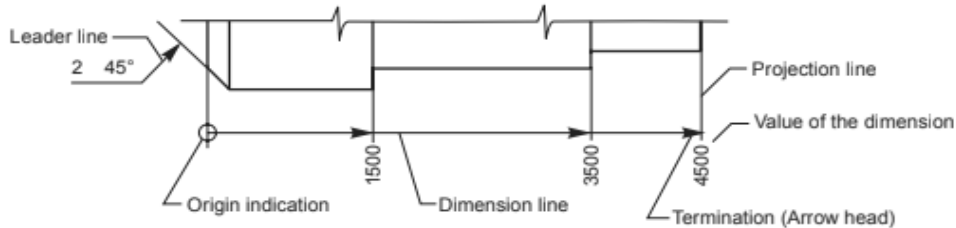


Fig. 2.28 Elements of dimensioning

### Conventions:

1. Projection and dimension lines should be drawn as thin continuous lines.
2. Projection lines should extend slightly beyond the respective dimension lines.
3. Projection lines should be drawn perpendicular to the feature being dimensioned. Where necessary, they may be drawn obliquely, but parallel to each other (Fig. 2.30). However, they must be in contact with the feature.
4. Projection lines and dimension lines should not cross each other, unless it is unavoidable (Fig. 2.31).
5. A dimension line should be shown unbroken, even where the feature to which it refers, is shown broken (Fig. 2.32).
6. A centre line or the outline of a part should not be used as a dimension line, but may be used in place of projection line (Fig. 2.31).

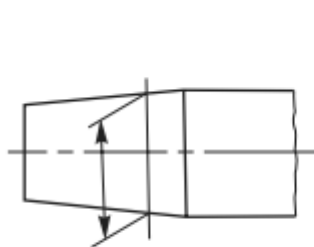


Fig. 2.30

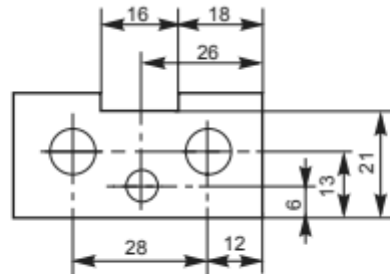


Fig. 2.31



Fig. 2.32

### Tip:

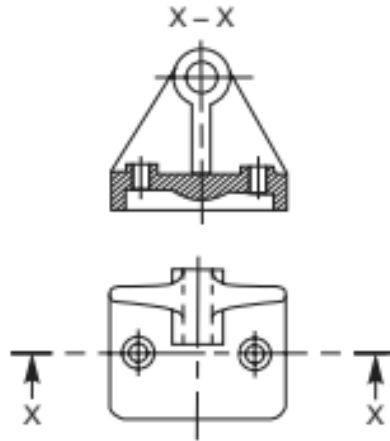
To speed up the drafting process draw some lines and apply the desired properties on them before saving the template file. Then while drafting a design the same properties can be copied to other objects by using Match Properties command.

### Convention for sectional views.

The cutting plane(s) should be indicated by means of type H line. The cutting plane should be identified by capital letters and the direction of viewing should be indicated by arrows. The section should be indicated by the relevant designation (Fig. 2.15).

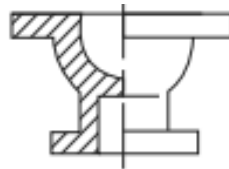
In principle, ribs, fasteners, shafts, spokes of wheels and the like are not cut in longitudinal sections and therefore should not be hatched (Fig. 2.16).

Figure 2.17 represents sectioning in two parallel planes and Fig. 2.18, that of sectioning in three continuous planes.



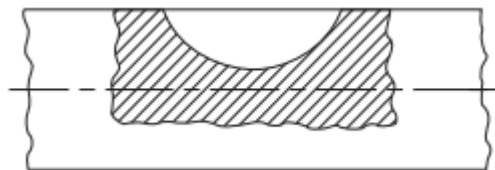
**Fig. 2.15** Cutting plane indication

1. Half Section: Symmetrical parts may be drawn, half in plain view and half in section (Fig 2.23).

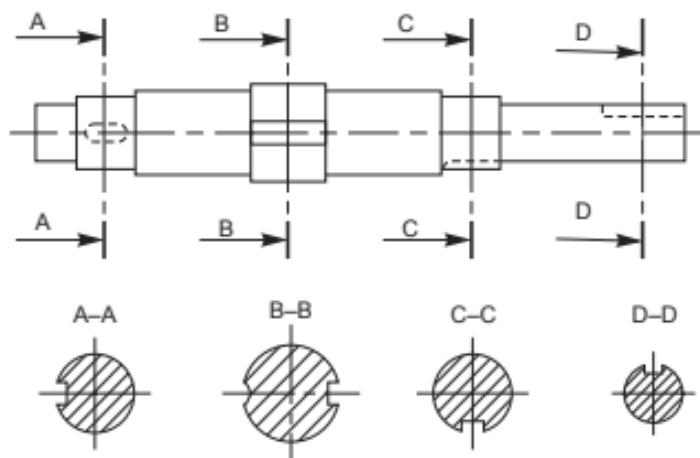


**Fig. 2.23** Half section

2. Local Section: A local section may be drawn if half or full section is not convenient. The local break may be shown by a continuous thin free hand line



3. Arrangement of successive sections: Successive sections may be placed separately, with designations for both cutting planes and sections (Fig. 2.25) or may be arranged below the cutting planes.



**Fig. 2.25** Successive sections



## EXPERIMENT - 01

### Creating a Template with Title Block & all other settings

#### Aim:

To create a template file with following settings:

1. Layout with **A4 Paper & Title Block**. (Set the zoom to 1xp.)
2. Layer named Solids with **Lineweight 0.8mm**.
3. Layer named Dimensions with **Lineweight 0.35mm**.
4. Layer named Hidden with **Lineweight 0.4mm & Linetype - Dashed2**.
5. Layer named Axis & others with default lineweight & **Linetype - Center2**.
6. Text Style set to **Simplex.shx**.
7. Set Dimension **text height & arrow size** to **4**, text alignment to **ISO standard**.

#### Apparatus:

Hardware: Desktop System with i3 processor, 8 GB RAM, Graphics Card & 250 GB HDD.

Software: Windows 7 64-bit OS, \_\_\_\_\_ Package.

#### Commands:

Startup, Lineweight (LW), Linetype (LT), Layers (LA), Save as, Line (L), Text (DT), Text Style (ST), Dimension Style (D), Layout

#### Procedure:

1. Open the AutoCAD Software on the system.
2. Set the paper size to A4 from Layout settings
  - a. Right click on the Layout and select the Page Setup Manager and select A4 Sheet and choose Landscape and close it.
3. Set the scale in Zoom option select the Scale and enter the value as 0.5xp.
4. Create the Title Block by drawing rectangle of 170X65 and Explode by command 'X' and take the offset of the lines and complete the Title Block table as shown in diagram.
5. Create a Layer the command is LA and select the number of layer required and name them and set the properties like line lineweight, linetype.
6. Set the Text Style by the command DT and change the text style by command ST and choose the Font Name simplex.shx and set current apply and close.
7. Set the Dimension by command D and modify text height and arrow size to 4, text alignment to ISO standard.
8. For Saving the file save as in that files of type should be AutoCAD Drawing Template and name the file and save in the drive and give the Description and save it. **By these template it will be easy for the Drawing and the setup will be ready with the settings.**

**EXPERIMENT – 02**

**Orthographic Sectional Views**

**Aim:**

To draft the orthographic views with suitable sections as mentioned in the question.

**Apparatus:**

Hardware: Desktop System with i3 processor, 8 GB RAM, Graphics Card & 250 GB HDD.

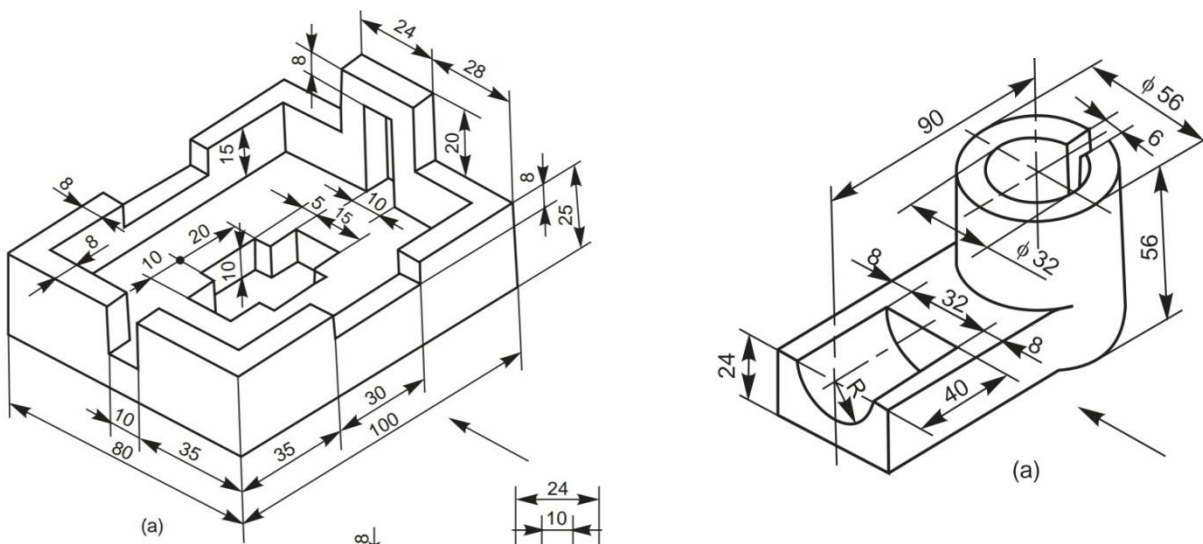
Software: Windows 7 64-bit OS, \_\_\_\_\_ Package.

**Commands:**

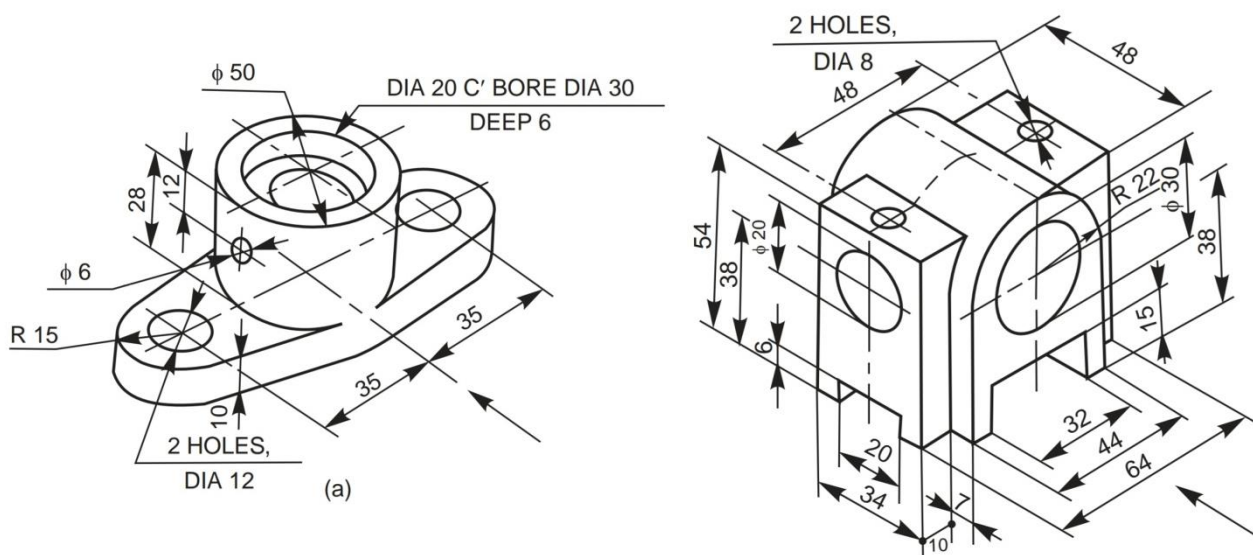
Layers (LA), Line (L), Ortho, Match properties (MA), Text (DT), Text Style (ST), Dimension

**Questions:**

1. Draw the sectional Front view & Left side view along with Top View.



2. Draw the sectional Front & Sectional Left side views along with Top View.



**EXPERIMENT – 03**

**Simple Machine Elements**

**Aim:**

To draft the orthographic views with suitable sections of simple machine parts.

**Apparatus:**

Hardware: Desktop System with i3 processor, 8 GB RAM, Graphics Card & 250 GB HDD.

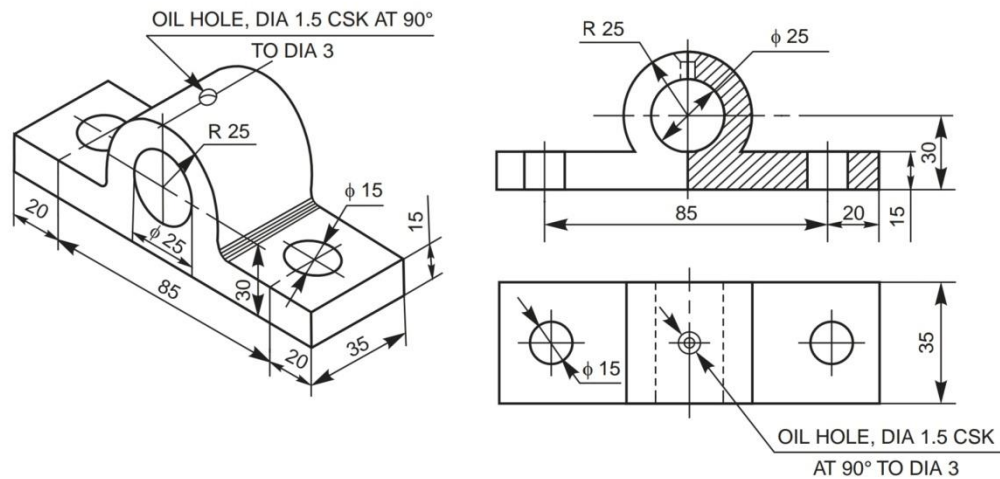
Software: Windows 7 64-bit OS, \_\_\_\_\_ Package.

**Commands:**

Layers (LA), Line (L), Circle (C), Offset (O), Mirror (MI), Hatch (HA), Ortho, Match properties (MA), Text (DT), Text Style (ST), Dimensions

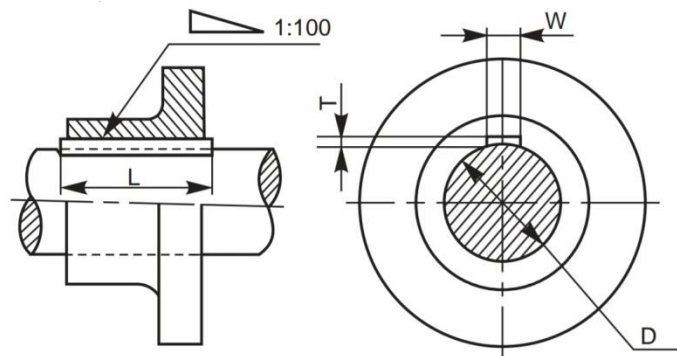
**Machine Parts:**

**Simple Machine Elements.**



**Fig. 12.2** Solid journal bearing

**Keys & Cotters**



**Fig. 6.2** Hollow saddle key

**EXPERIMENT – 04**

**Riveted Fastenings**

**Aim:**

To draft the sectional front view & Broken Top view of rivets as per the question.

**Apparatus:**

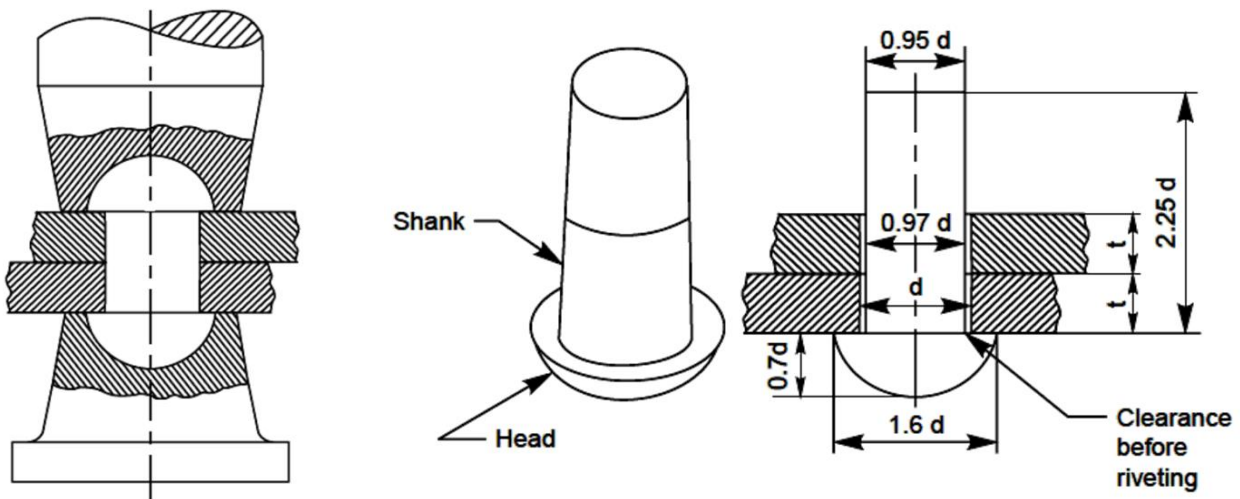
Hardware: Desktop System with i3 processor, 8 GB RAM, Graphics Card & 250 GB HDD.

Software: Windows 7 64-bit OS, \_\_\_\_\_ Package.

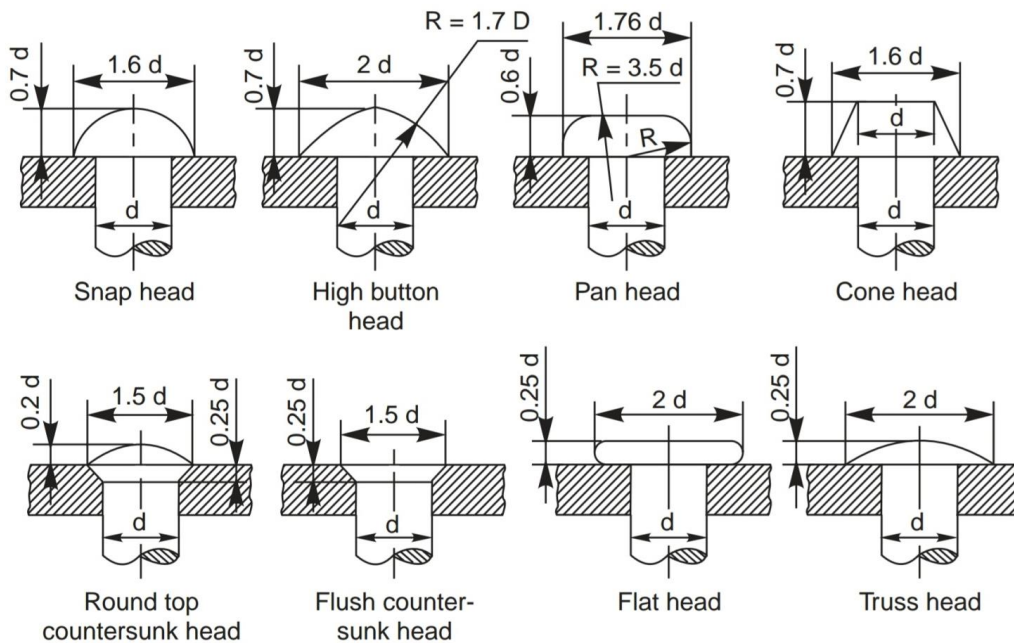
**Commands:**

Layers (LA), Line (L), Circle (C), Offset (O), Mirror (MI), Hatch (HA), Ortho, Match properties (MA), Text (DT), Text Style (ST), Dimensions

**Process of Riveting:**



**Types of Rivet Heads:**



**Other important formulae:**

$t_1 = 1.125t$  - thickness of the single strap plate.

$t_2 = 0.75t$  - thickness of the double strap plate.

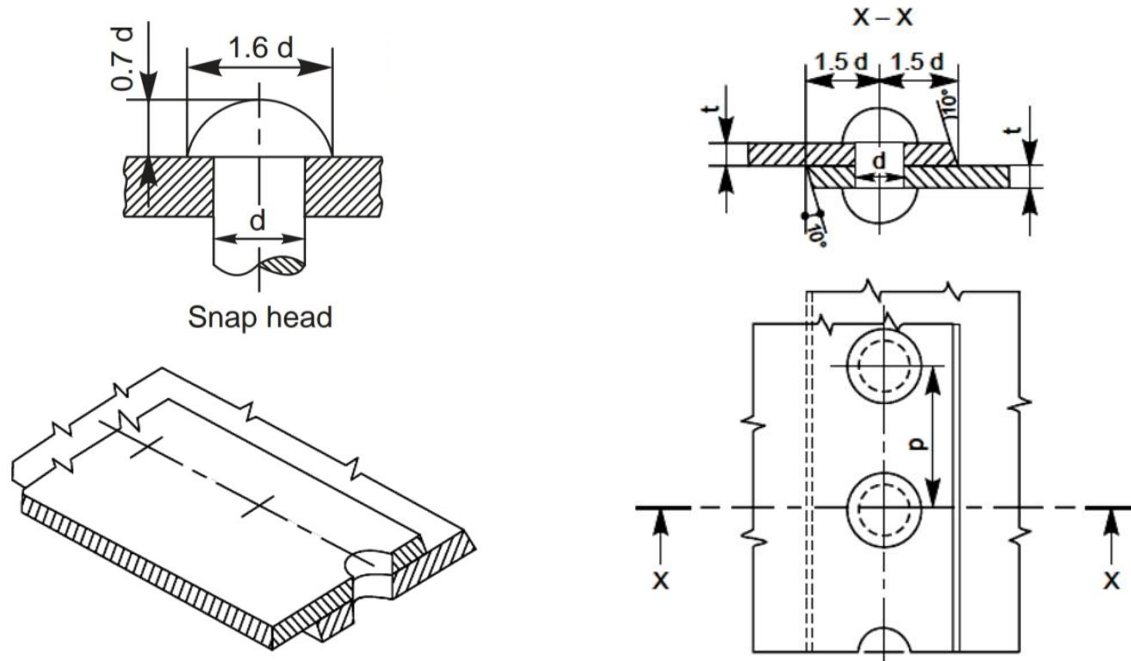
$P = 3d$  - Distance between adjacent rows of rivets

$P_r = 0.8P$  (for chain riveting) - distance between adjacent columns of rivets.

$P_r = 0.6P$  (for zig zag riveting) - distance between adjacent columns of rivets.

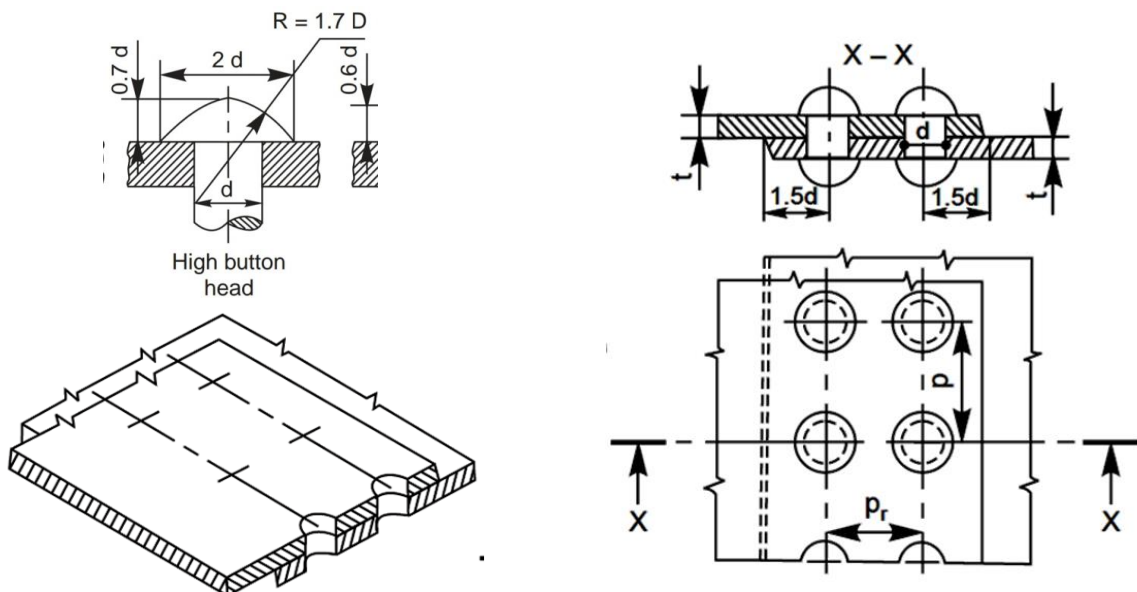
**Question No 1**

Draw sectional front view & broken top view of a **Single riveted lap joint** for sheets of thickness,  $t=16\text{mm}$ . Use **snap head type** of rivet head.



**Question No 2**

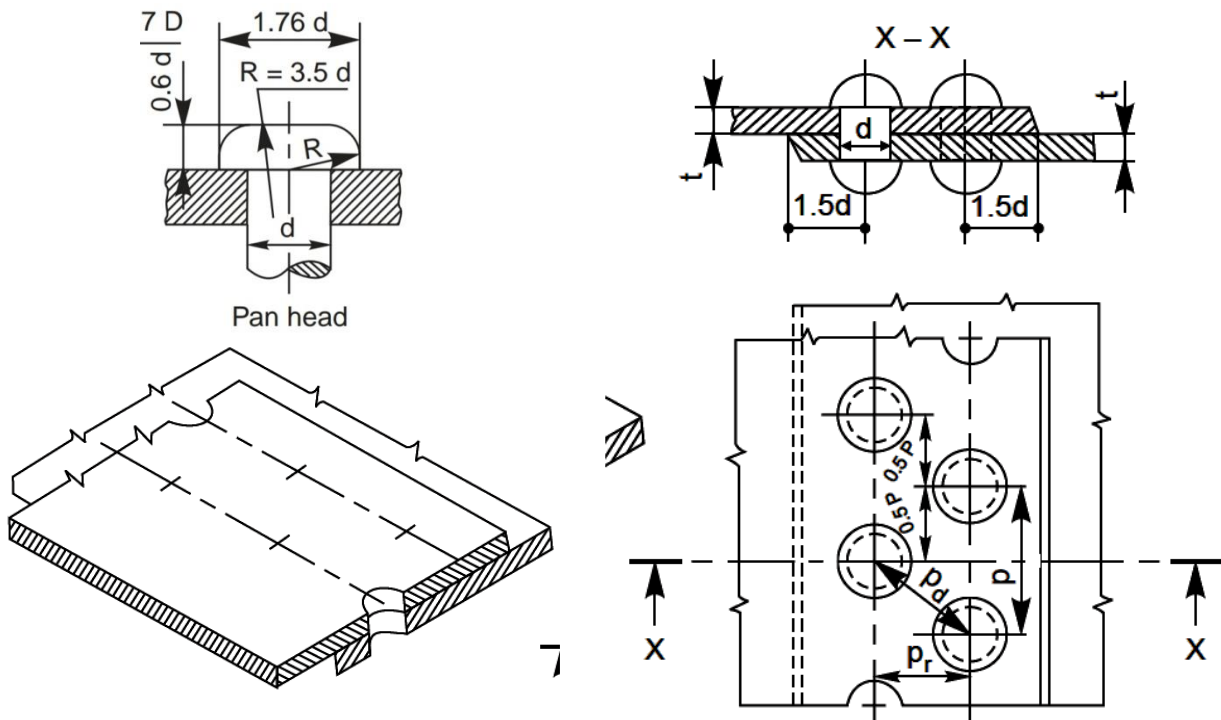
Draw sectional front view & broken top view of a **Double riveted chain lap joint** for sheets of thickness,  $t=12\text{mm}$ . Use high button head type of rivet head.





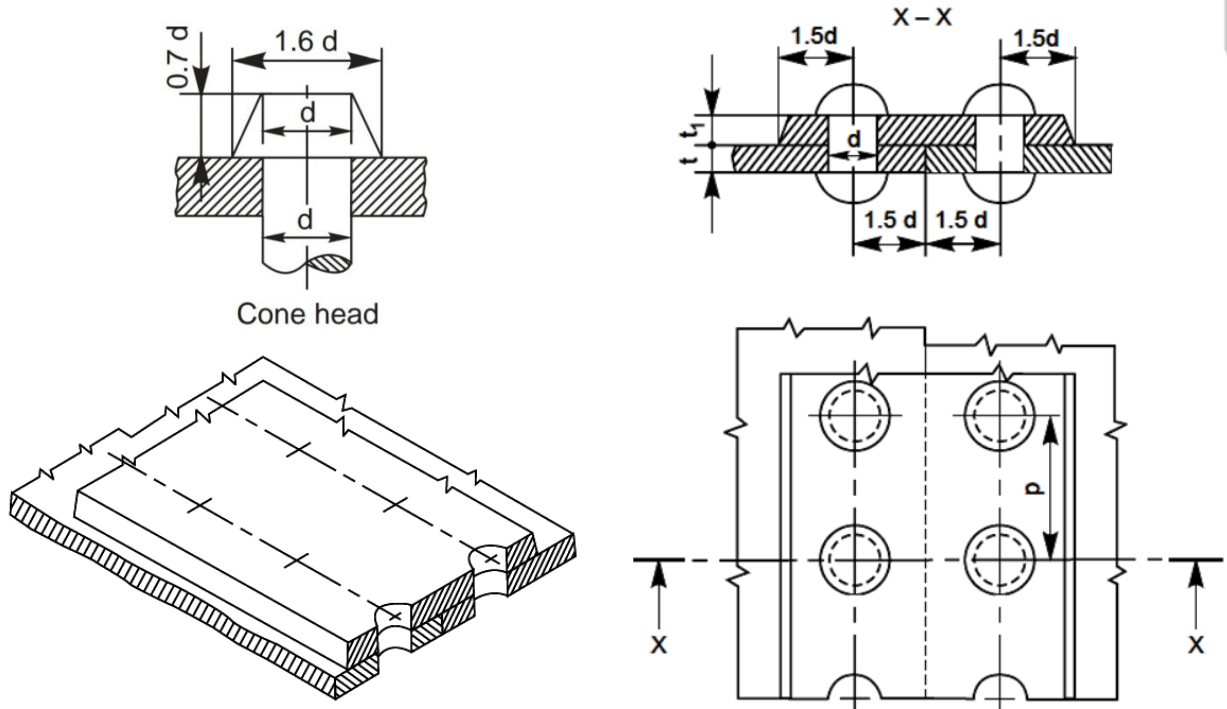
**Question No 3**

Draw sectional front view & broken top view of a **Double riveted zig zag lap joint** for sheets of thickness,  $t=12\text{mm}$ . Use **Pan Head** type of rivet head.



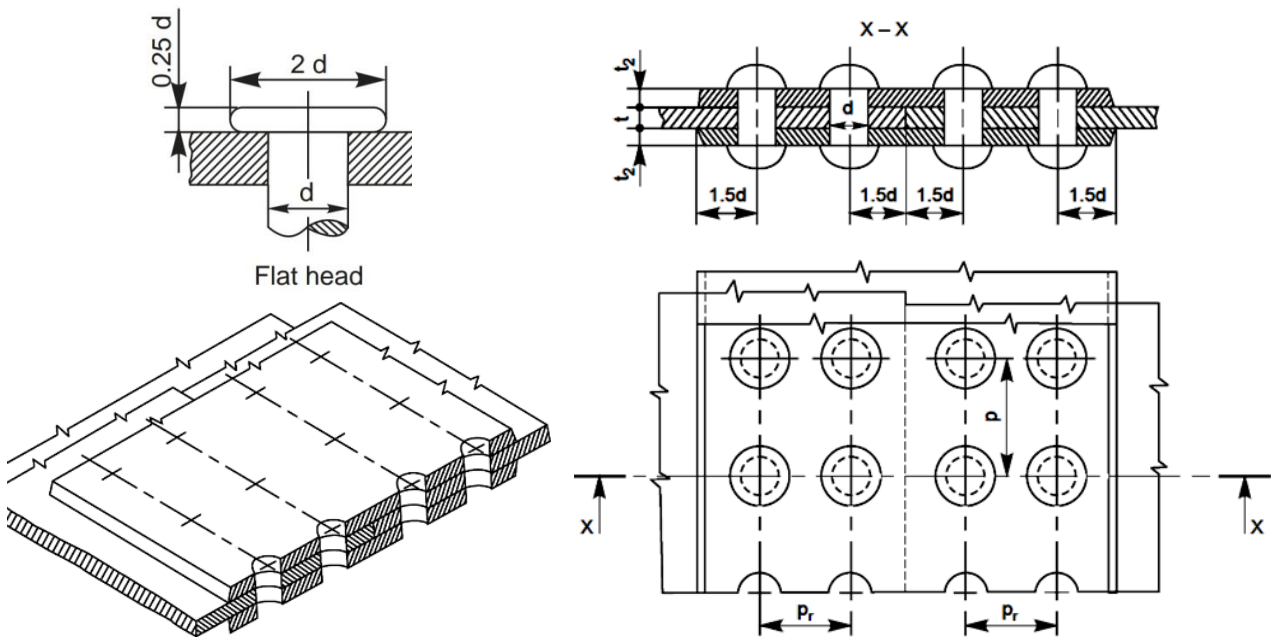
**Question No 4**

Draw sectional front view & broken top view of a **Single strapped Single riveted butt joint** for sheets of thickness,  $t=12\text{mm}$ . Use **Cone Head** type of rivet head.



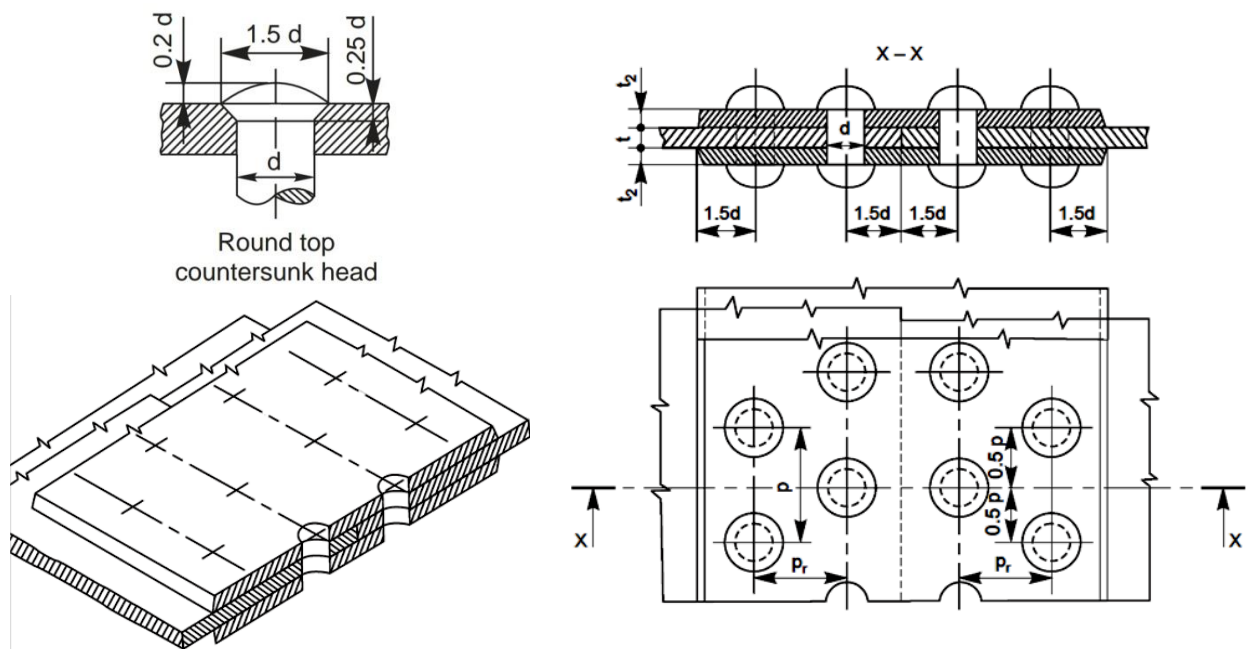
**Question No 5**

Draw sectional front view & broken top view of a **Single strapped Double riveted chain butt joint** for sheets of thickness,  $t=9\text{mm}$ . Use **Flat Head** type of rivet head.



**Question No 6**

Draw sectional front view & broken top view of a **Double strapped double riveted zig zag butt joint** for sheets of thickness,  $t=9\text{mm}$ . Use **Round Top Countersunk** type of rivet head.



### EXPERIMENT – 05

#### Screwed Fastenings

**Aim:**

To draft the orthographic projections of screwed fasteners as per the question.

**Apparatus:**

Hardware: Desktop System with i3 processor, 8 GB RAM, Graphics Card & 250 GB HDD.

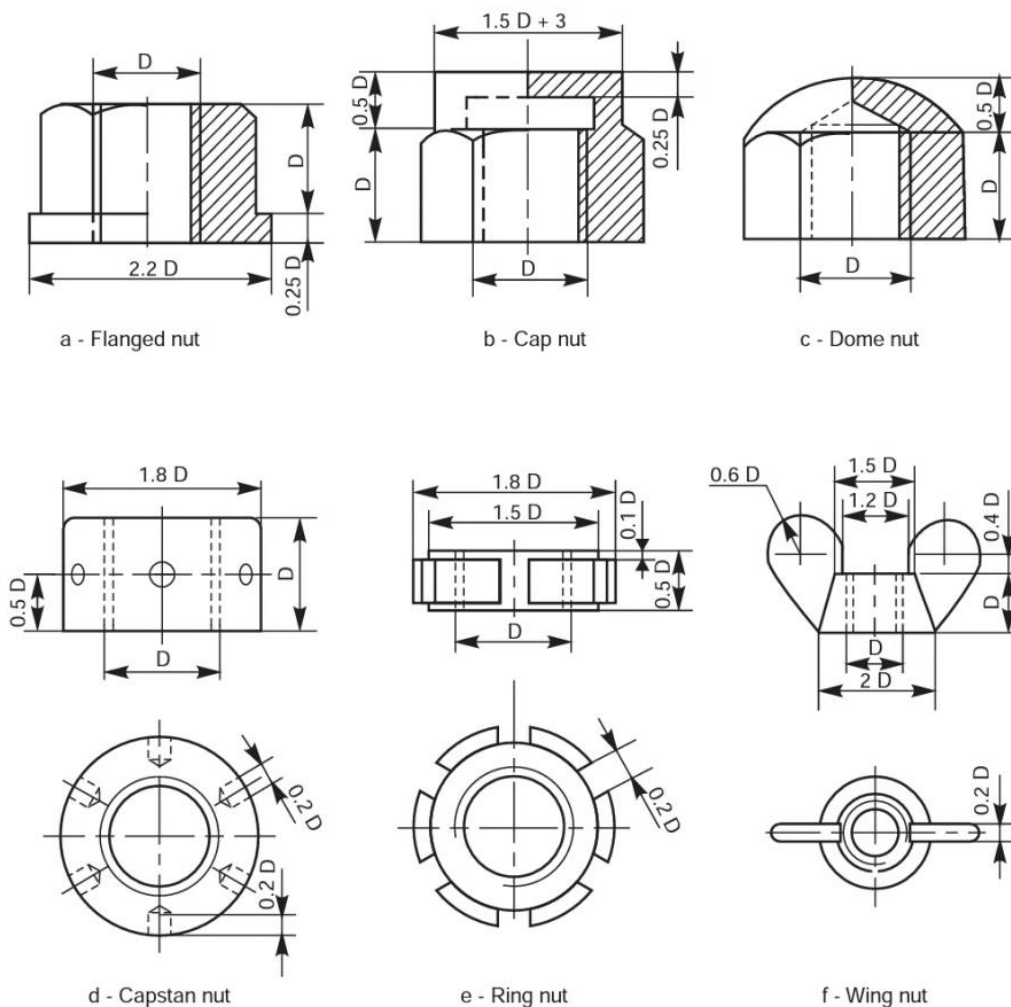
Software: Windows 7 64-bit OS, \_\_\_\_\_ Package.

**Commands:**

Layers (LA), Line (L), Circle (C), Offset (O), Mirror (MI), Hatch (HA), Ortho, Match properties (MA), Text (DT), Text Style (ST), Dimensions

**Questions:**

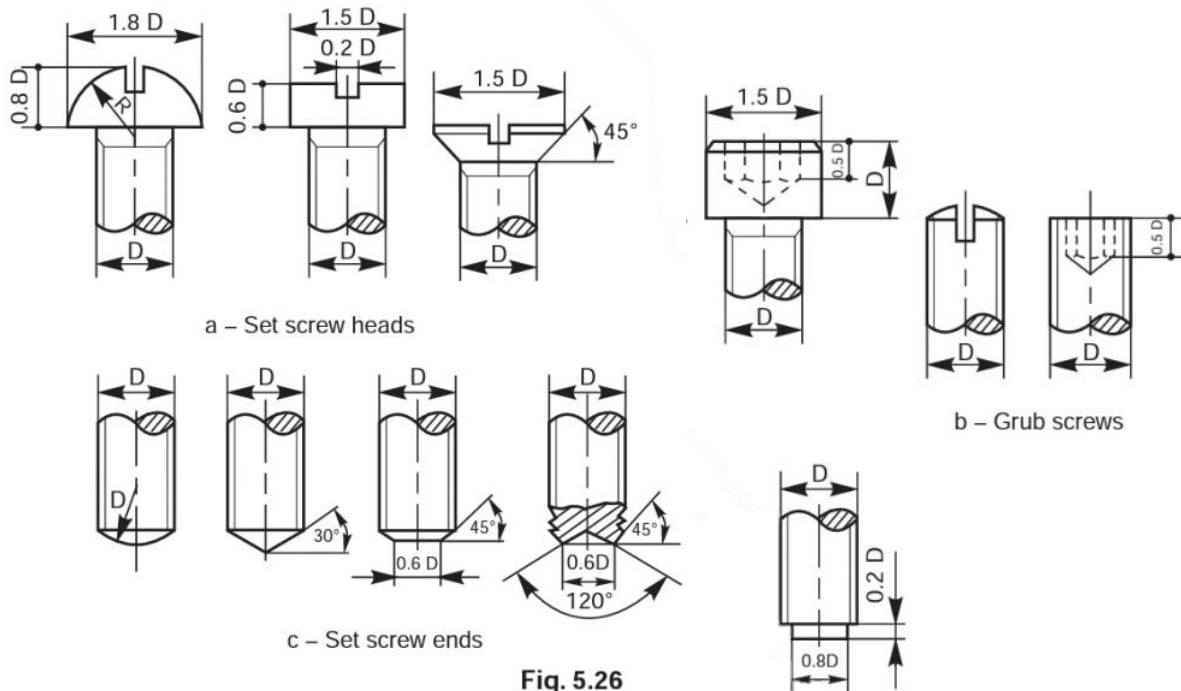
1. Draft the nuts given below using ratios given in the diagram assuming  $D = 20$  mm.



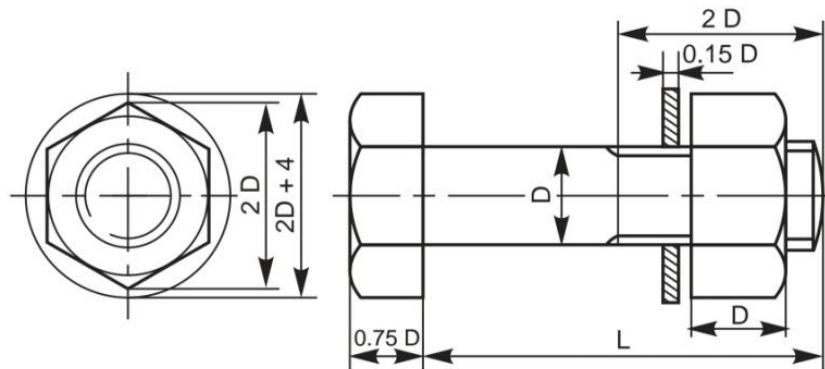
**Fig. 5.23** Other forms of nuts



2. Draft the nuts given below using ratios given in the diagram assuming  $D = 20$  mm.

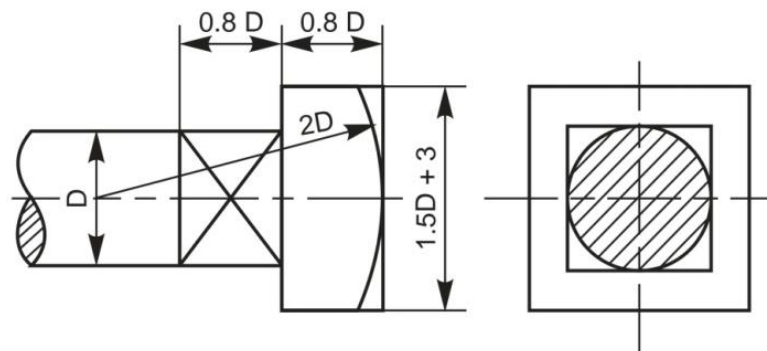


3. Draw the front view top view and side view of a hexagonal bolt and nut assembly.



**Fig. 5.17** A hexagonal headed bolt with a nut and a washer in position

4. Draw the front view, side view and a top view of a square bolt and nut assembly.



**Fig. 5.18** Square headed bolt with square neck

**EXPERIMENT – 06**

**Joints & Couplings**

**Aim:**

To draft the suitably sectioned front view & side views of the joints & couplings as per question.

**Apparatus:**

Hardware: Desktop System with i3 processor, 8 GB RAM, Graphics Card & 250 GB HDD.

Software: Windows 7 64-bit OS, \_\_\_\_\_ Package.

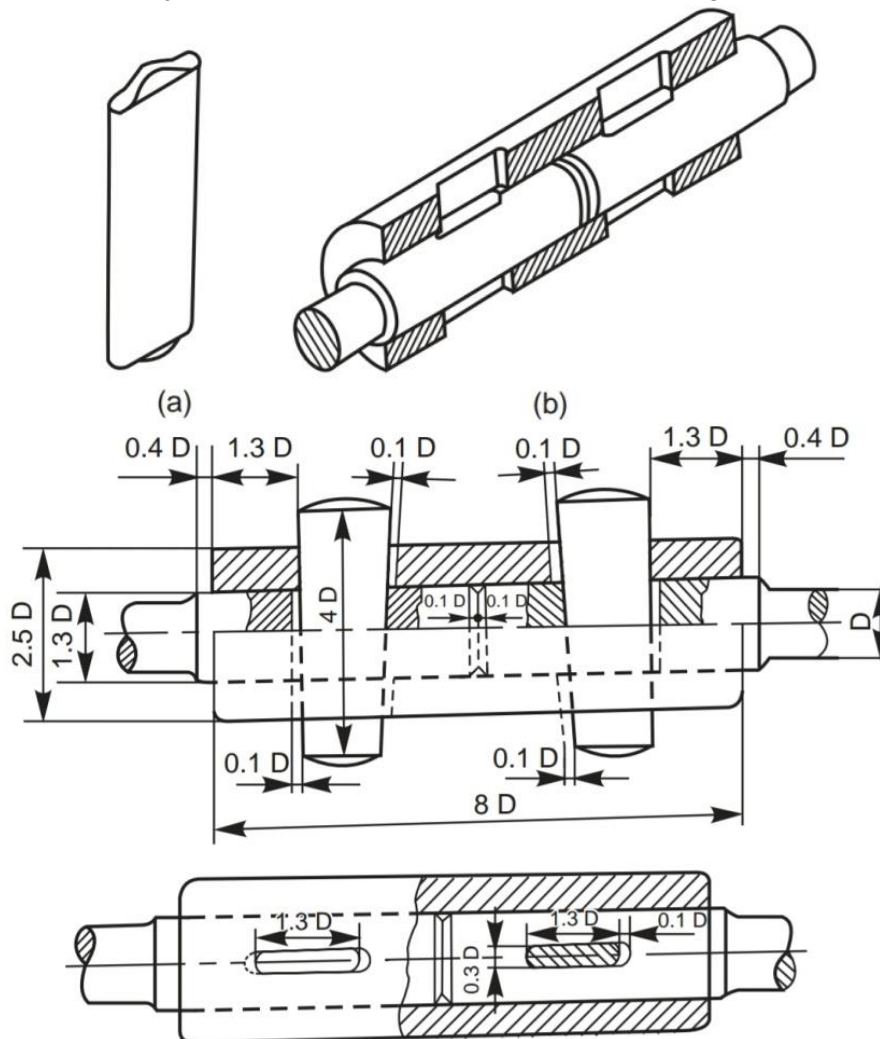
**Commands:**

Layers (LA), Line (L), Circle (C), Offset (O), Mirror (MI), Hatch (HA), Ortho, Match properties (MA), Text (DT), Text Style (ST), Dimensions

**Questions:**

**Double Cottered Joint / Cottered Joint with Sleeve**

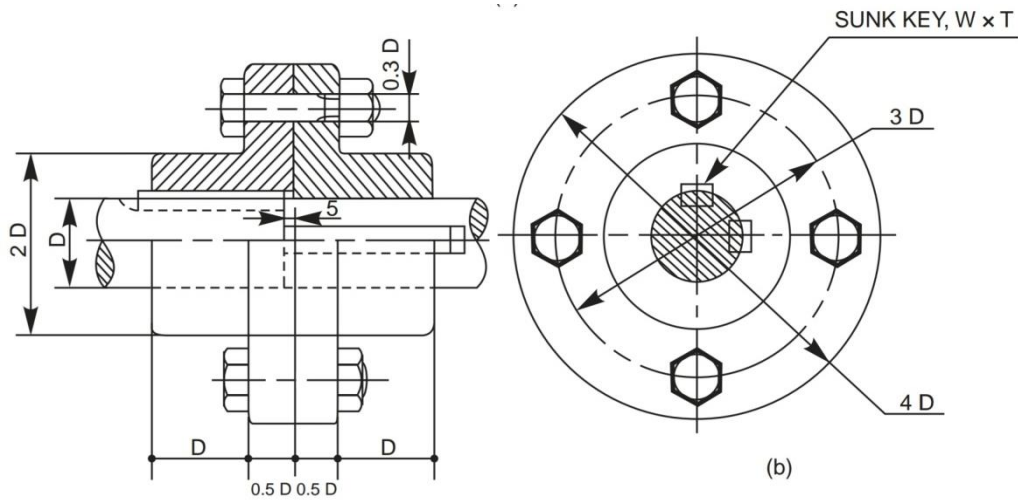
1. Draw a double riveted joint with diameter of shaft as **20mm** assuming suitable ratios.





**Flanged Coupling**

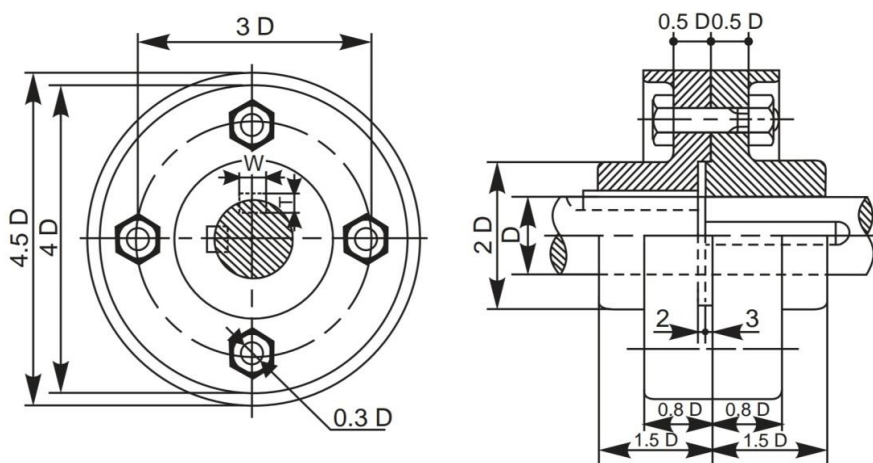
4. Draw a Flanged Coupling for a shaft of diameter 20mm using ratios provided in the diagram below:



**Fig. 7.4** Flanged coupling

**Protected Flanged Coupling**

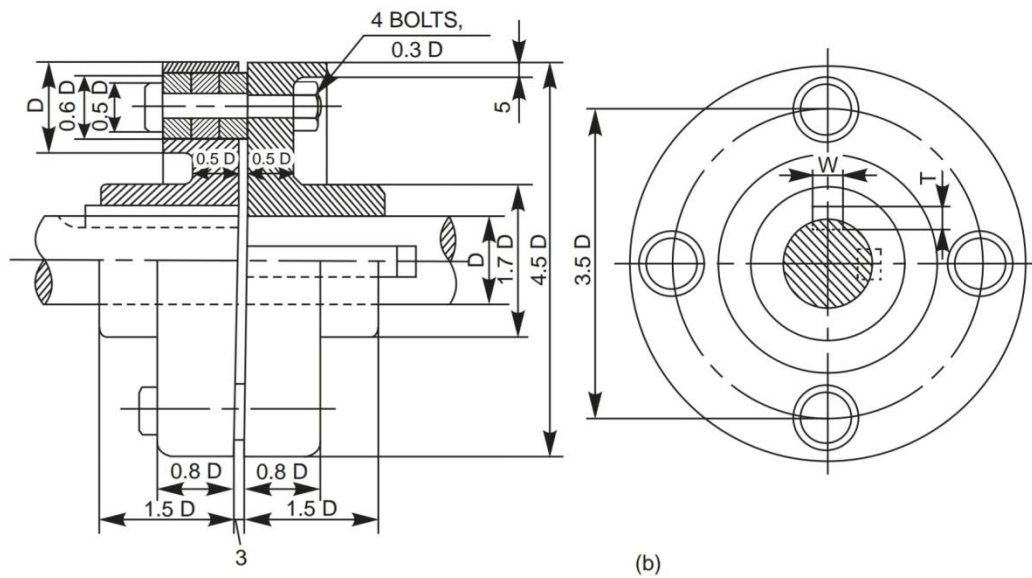
5. Draw a Protected Flanged Coupling for a shaft of diameter 20mm using ratios provided in the diagram below:



**Fig. 7.5** Protected flanged coupling

**Bushed Pin Type Flanged Coupling**

6. Draw a Bushed Pin Type Flanged Coupling for a shaft of diameter 20mm using ratios provided in the diagram below:



**Fig. 7.7** Bushed pin type flanged coupling

**PART II**

**ASSEMBLY DRAWING**  
**(SOLIDWORKS/ CATIA/ PRO-E)**

**EXPERIMENT: 07**

**Stuffing Boxes**

**Aim:**

To model the stuffing box assembly from given dimensions using available CAD package.

**Apparatus:**

Hardware: Desktop System with i3 processor, 8 GB RAM, Graphics Card & 250 GB HDD.

Software: Windows 7 64-bit OS, \_\_\_\_\_ Package.

**Commands / Features used (in following modules):**

Sketcher: Line, Circle, Construction Geometry, Dimensioning, Constraints

Part: Extrude, Revolve, Add, Subtract

Assembly: Axis coincidence

Drawing: Insert View, Insert Projection, Generate Sectional View, Dimensioning

**Question:**

1. Complete the following tasks using Solidworks,
  - a. Model all the parts given below in part module.
  - b. Assemble all the parts using assembly module.
  - c. Generate the half sectional front view, Top View & side view of the assembly using drawing module. Also generate the Bill of Materials & number the parts shown in the assembly using balloons.

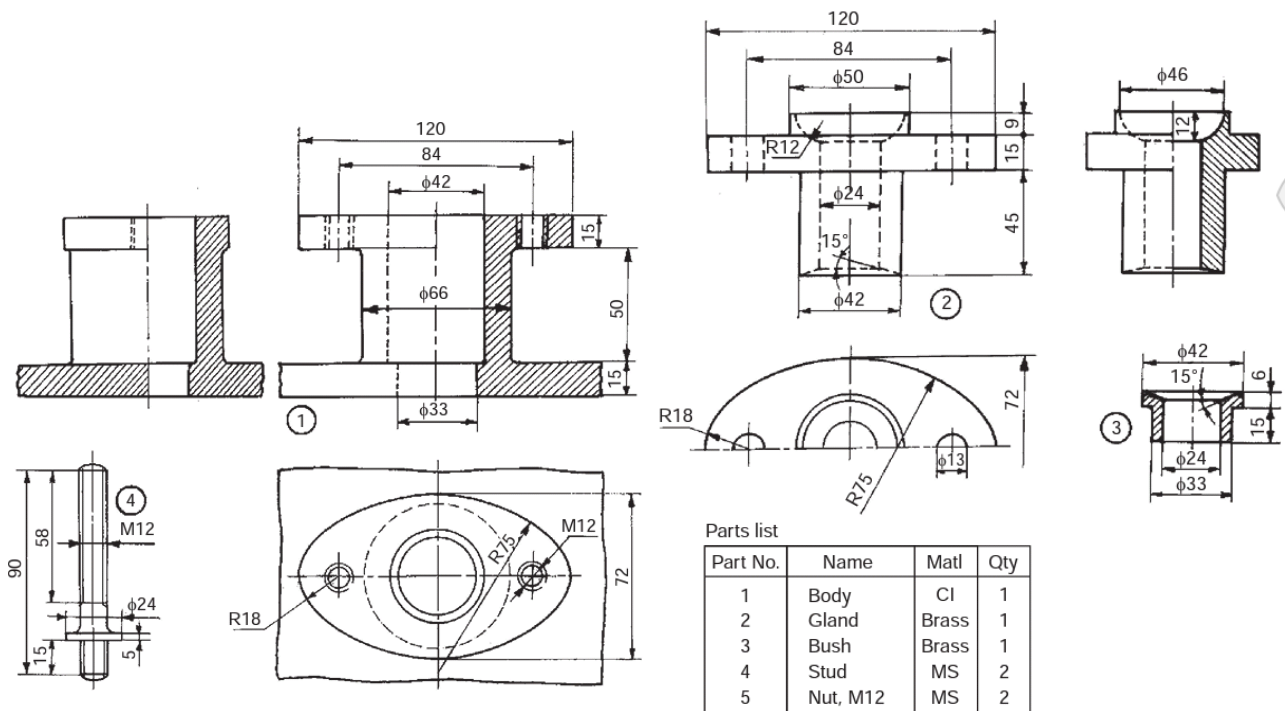


Fig. 18.1 Stuffing box

**Procedure:**

1. Model all the parts given in parts module & apply material as shown in the parts table.
2. Assemble the parts suitably using assembly module.
3. Draft the assembly, mark part numbers using balloons & take print of the same.
4. Note down the following values:
  - a. Total mass of the assembly = \_\_\_\_\_
  - b. Distance between centre of gravity of each part from its lower most point when it is placed vertically? \_\_\_\_\_

**Precautions:**

1. Do not save your files on desktop or C drive. (They will be automatically erased on system restart.)
2. Save your file in the D drive in a folder of your name or roll number.
3. Don't install, uninstall or change any setting the system.
4. Don't tamper or exchange any hardware (mouse/keyboard etc)
5. Inform about any malfunctions to the instructor right away.

**Viva Questions:**

1. What are the applications of Stuffing Box?
2. What type of fitting is used between the following pairs & why?
  - a. Body & Gland
  - b. Body & Bush
  - c. Gland & Piston Shaft
  - d. Bush & Piston Shaft
3. What is the total mass of the assembly after applying the materials mentioned in the Parts Table? \_\_\_\_\_
4. What is the height of centre of gravity of each part from its lower most point when it is placed vertically? \_\_\_\_\_



**EXPERIMENT: 08**

**Cross Heads**

**Aim:**

To model the cross heads assembly from given dimensions using available CAD package.

**Apparatus:**

Hardware: Desktop System with i3 processor, 8 GB RAM, Graphics Card & 250 GB HDD.

Software: Windows 7 64-bit OS, \_\_\_\_\_ Package.

**Commands / Features used (in following modules):**

Sketcher: Line, Circle, Construction Geometry, Dimensioning, Constraints

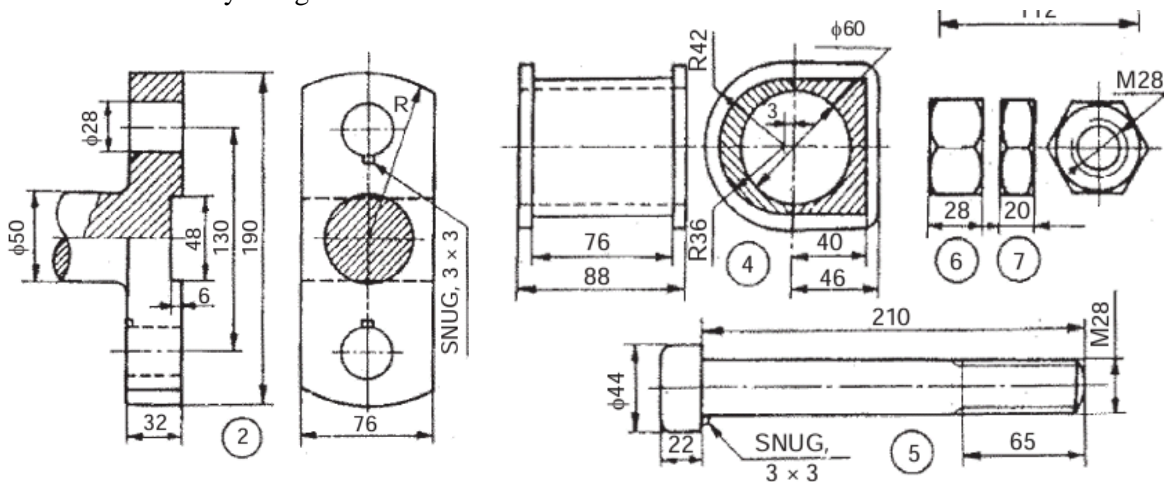
Part: Extrude, Revolve, Add, Subtract

Assembly: Axis coincidence

Drawing: Insert View, Insert Projection, Generate Sectional View, Dimensioning

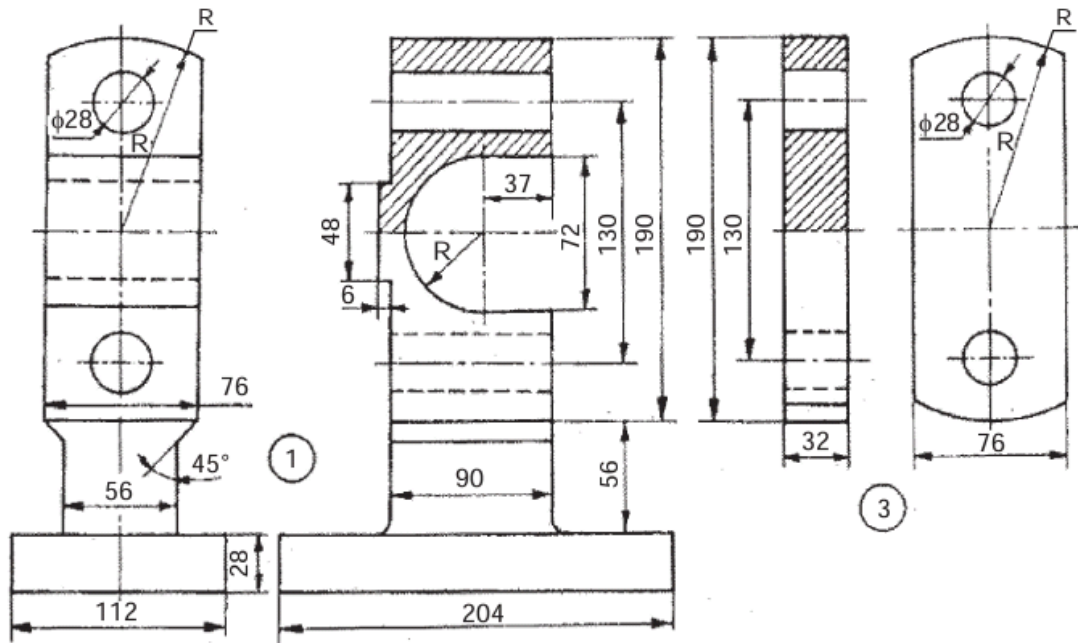
**Question & Part Details:**

2. Complete the following tasks using Solidworks,
  - a. Model all the parts given below in part module.
  - b. Assemble all the parts using assembly module.
  - c. Generate the half sectional front view, Top View & side view of the assembly using drawing module. Also generate the Bill of Materials & number the parts shown in the assembly using balloons.



Parts list

Sl. No.	Name	Matl	Qty
1	Body	CI	1
2	Rod end	MS	1
3	Cover plate	MS	1
4	Brasses	Brass	1
5	Bolt	—	2
6	Nut	—	2
7	Lock nut	—	2



**Procedure:**

1. Model all the parts given in parts module & apply material as shown in the parts table.
2. Assemble the parts suitably using assembly module.
3. Draft the assembly, mark part numbers using balloons & take print of the same.
4. Note down the following values:
  - a. Total mass of the assembly = \_\_\_\_\_
  - b. Distance between centre of gravity of each part from its lowermost point when it is placed vertically? \_\_\_\_\_

**Precautions:**

1. Do not save your files on desktop or C drive. (They will be automatically erased on system restart.)
2. Save your file in the D drive in a folder of your name or roll number.
3. Don't install, uninstall or change any setting the system.
4. Don't tamper or exchange any hardware (mouse/keyboard etc)
5. Inform about any malfunctions to the instructor right away.

**Viva Questions:**

1. What are the applications of Cross Head?
2. What type of fitting is used between the following pairs & why?
 

a. Body & Brasses	c. Bolt & Rod End
b. Bolt & Body	d. Bolt & Cover End
3. What is the total mass of the assembly after applying the materials mentioned in the Parts Table? \_\_\_\_\_
4. What is the height of centre of gravity of each part from its lowermost point when it is placed vertically? \_\_\_\_\_

**EXPERIMENT: 09**

**Eccentrics**

**Aim:**

To model the Eccentrics assembly from given dimensions using available CAD package.

**Apparatus:**

Hardware: Desktop System with i3 processor, 8 GB RAM, Graphics Card & 250 GB HDD.

Software: Windows 7 64-bit OS, \_\_\_\_\_ Package.

**Commands / Features used (in following modules):**

Sketcher: Line, Circle, Construction Geometry, Dimensioning, Constraints

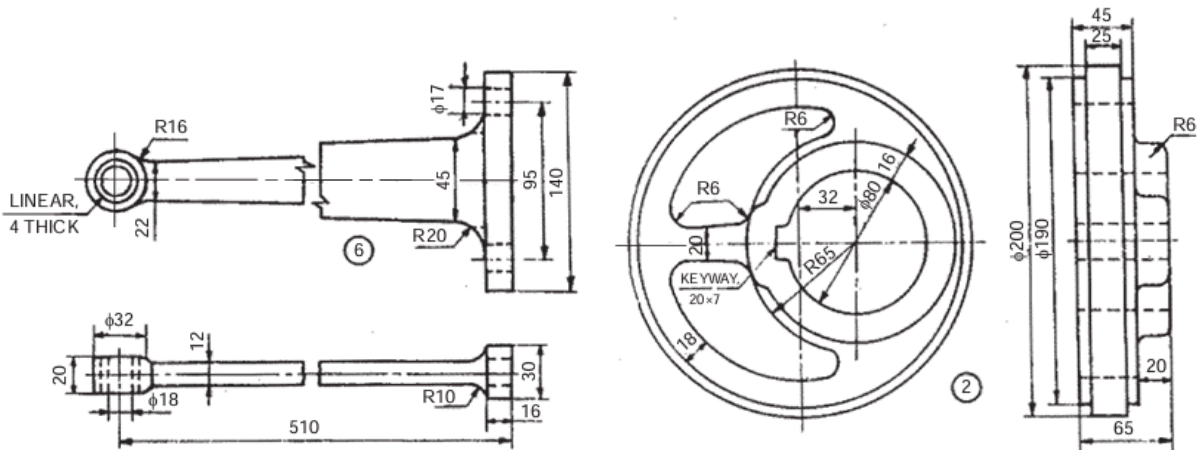
Part: Extrude, Revolve, Add, Subtract

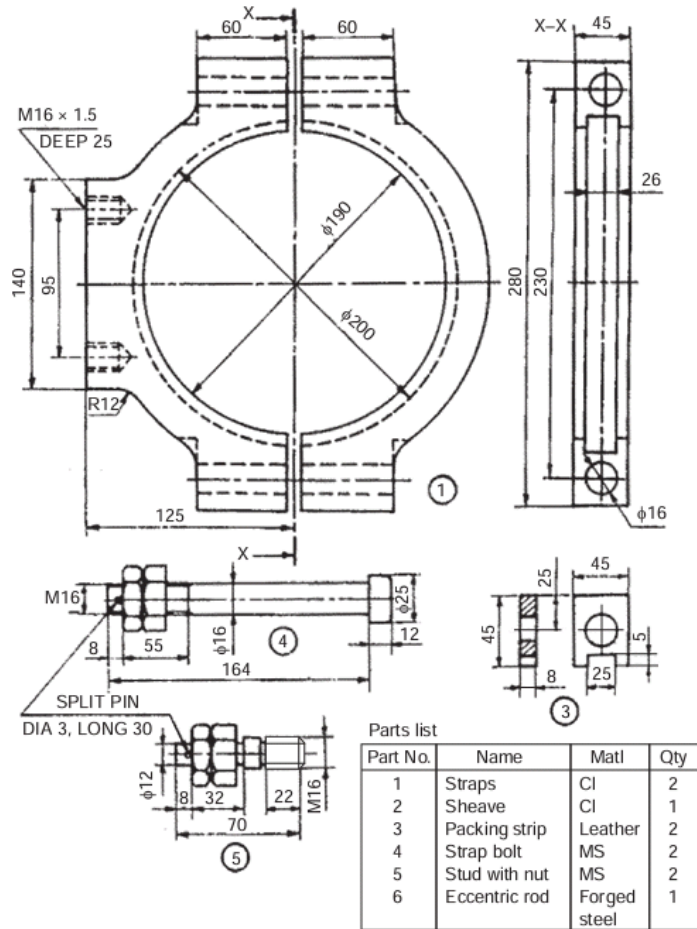
Assembly: Axis coincidence

Drawing: Insert View, Insert Projection, Generate Sectional View, Dimensioning

**Question & Part Details:**

3. Complete the following tasks using Solidworks,
  - a. Model all the parts given below in part module.
  - b. Assemble all the parts using assembly module.
  - c. Generate the half sectional front view, Top View & side view of the assembly using drawing module. Also generate the Bill of Materials & number the parts shown in the assembly using balloons.





**Procedure:**

1. Model all the parts given in parts module & apply material as shown in the parts table.
2. Assemble the parts suitably using assembly module.
3. Draft the assembly, mark part numbers using balloons & take print of the same.
4. Note down the following values:
  - a. Total mass of the assembly = \_\_\_\_\_
  - b. Distance between centre of gravity of each part from its lowermost point when it is placed vertically? \_\_\_\_\_

**Precautions:**

1. Do not save your files on desktop or C drive. (They will be automatically erased on system restart.)
2. Save your file in the D drive in a folder of your name or roll number.
3. Don't install, uninstall or change any setting the system.
4. Don't tamper or exchange any hardware (mouse/keyboard etc)
5. Inform about any malfunctions to the instructor right away.

**Viva Questions:**

1. What are the applications of Eccentrics?
2. What type of fitting is used between the following pairs & why?
  - a. Straps & sheave
  - b. Straps & strap bolt
  - c. Eccentric rod & the ring in it.

3. What is the total mass of the assembly after applying the materials mentioned in the Parts Table? \_\_\_\_\_
4. What is the height of centre of gravity of each part from its lowermost point when it is placed vertically? \_\_\_\_\_

**EXPERIMENT: 10**

**Lathe Tool Post**

**Aim:**

To model the assembly of Lathe tool post from given dimensions using available CAD package.

**Apparatus:**

Hardware: Desktop System with i3 processor, 8 GB RAM, Graphics Card & 250 GB HDD.

Software: Windows 7 64-bit OS, \_\_\_\_\_ Package.

**Commands / Features used (in following modules):**

Sketcher: Line, Circle, Construction Geometry, Dimensioning, Constraints

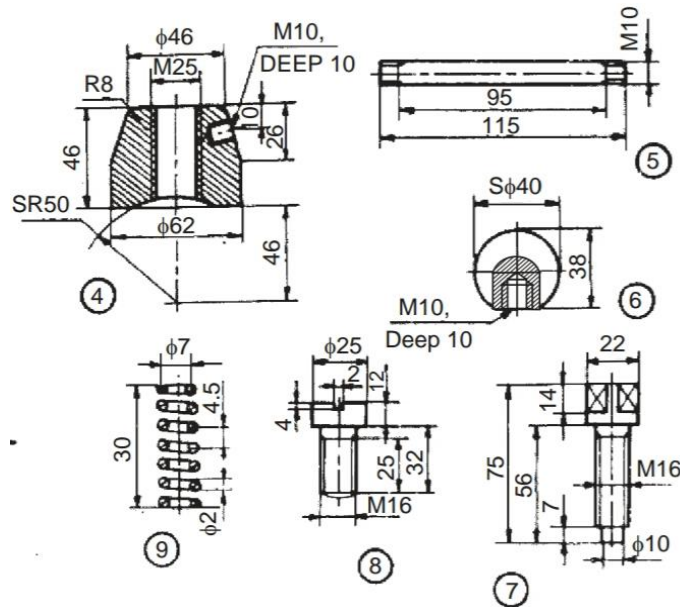
Part: Extrude, Revolve, Add, Subtract

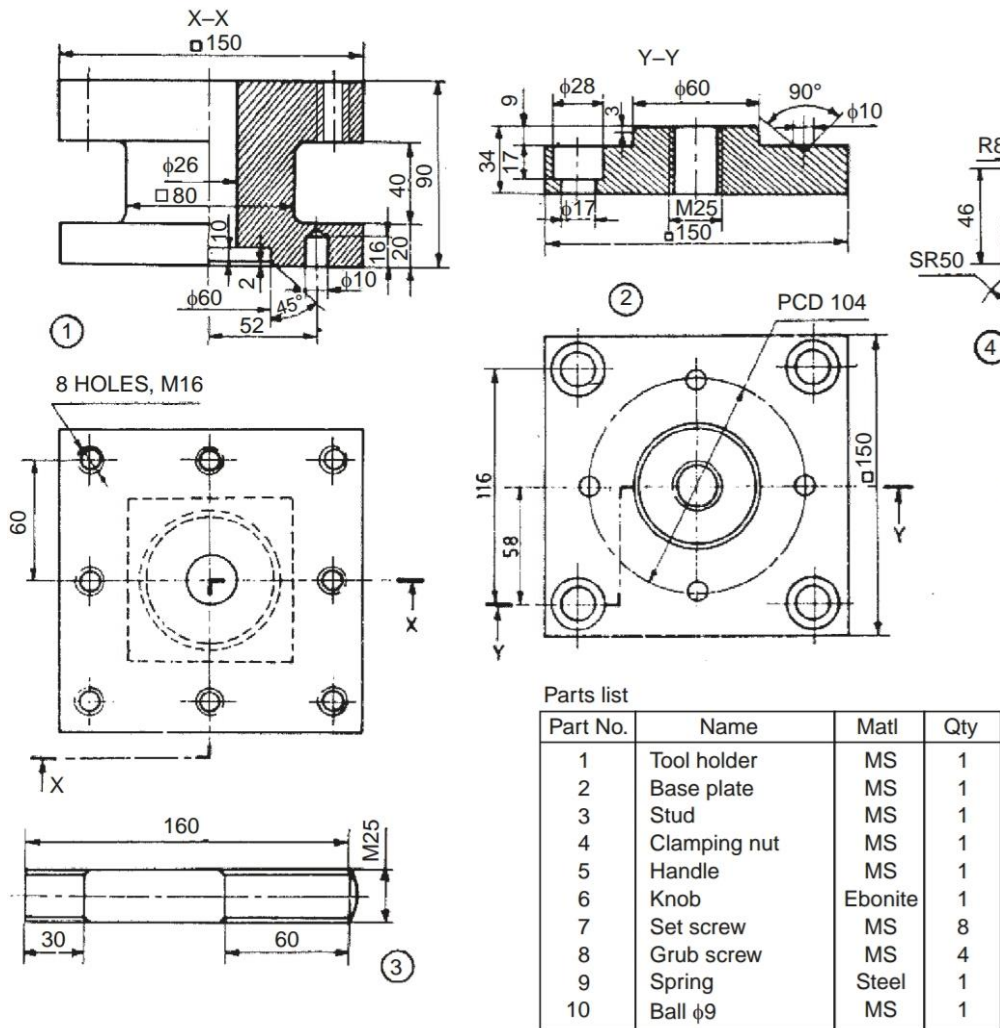
Assembly: Axis coincidence

Drawing: Insert View, Insert Projection, Generate Sectional View, Dimensioning

**Question & Part Details:**

4. Complete the following tasks using Solidworks,
  - a. Model all the parts given below in part module.
  - b. Assemble all the parts using assembly module.
  - c. Generate the half sectional front view, Top View & side view of the assembly using drawing module. Also generate the Bill of Materials & number the parts shown in the assembly using balloons.





**Procedure:**

1. Model all the parts given in parts module & apply material as shown in the parts table.
2. Assemble the parts suitably using assembly module.
3. Draft the assembly, mark part numbers using balloons & take print of the same.
4. Note down the following values:
  - a. Total mass of the assembly = \_\_\_\_\_
  - b. Distance between centre of gravity of each part from its lowermost point when it is placed vertically? \_\_\_\_\_

**Precautions:**

1. Do not save your files on desktop or C drive. (They will be automatically erased on system restart.)
2. Save your file in the D drive in a folder of your name or roll number.
3. Don't install, uninstall or change any setting the system.
4. Don't tamper or exchange any hardware (mouse/keyboard etc)
5. Inform about any malfunctions to the instructor right away.

**Viva Questions:**

1. What are the applications of Eccentrics?
2. What type of fitting is used between the following pairs & why?
  - a. Tool holder & base plate



3. What is the total mass of the assembly after applying the materials mentioned in the Parts Table? \_\_\_\_\_
4. What is the height of centre of gravity of each part from its lowermost point when it is placed vertically? \_\_\_\_\_



**EXPERIMENT: 11**

**Plummer Block**

**Aim:**

To model the Plummer block assembly from given dimensions using available CAD package.

**Apparatus:**

Hardware: Desktop System with i3 processor, 8 GB RAM, Graphics Card & 250 GB HDD.

Software: Windows 7 64-bit OS, \_\_\_\_\_ Package.

**Commands / Features used (in following modules):**

Sketcher: Line, Circle, Construction Geometry, Dimensioning, Constraints

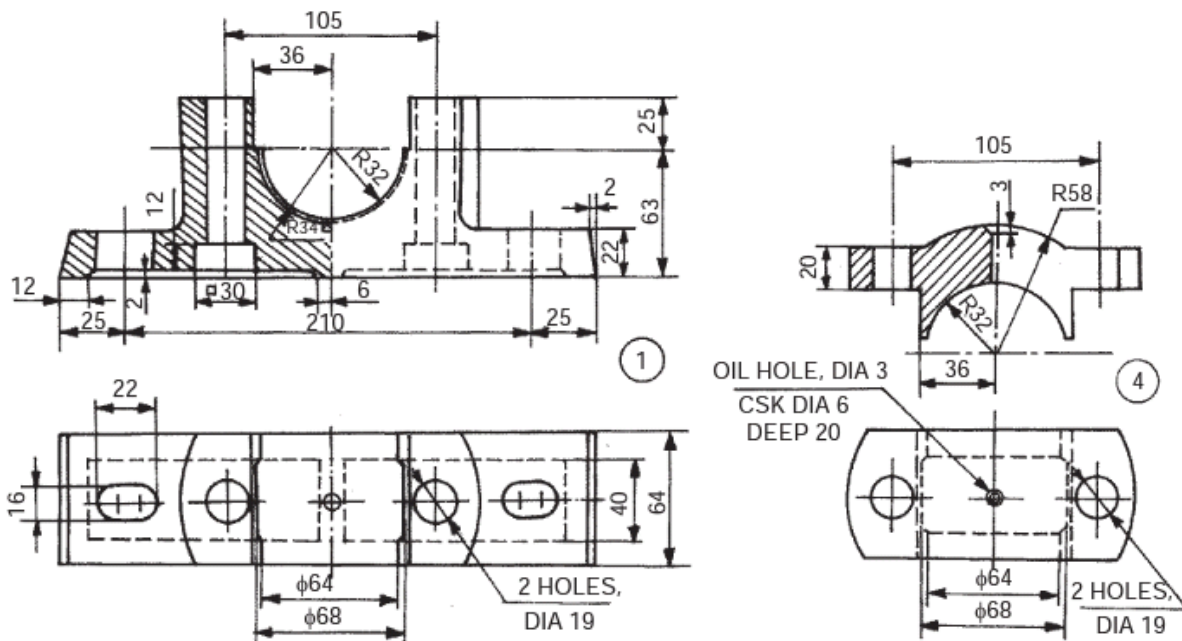
Part: Extrude, Revolve, Add, Subtract

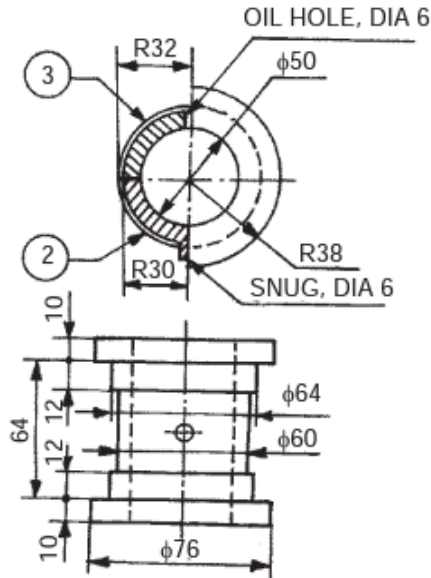
Assembly: Axis coincidence

Drawing: Insert View, Insert Projection, Generate Sectional View, Dimensioning

**Question & Part Details:**

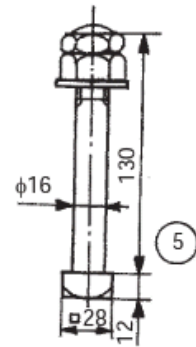
5. Complete the following tasks using Solidworks,
  - a. Model all the parts given below in part module.
  - b. Assemble all the parts using assembly module.
  - c. Generate the half sectional front view, Top View & side view of the assembly using drawing module. Also generate the Bill of Materials & number the parts shown in the assembly using balloons.





Parts list

Sl. No.	Name	Matl.	Qty.
1	Base	CI	1
2	Bearing brass	Bronze	1
3	Bearing brass	Bronze	1
4	Cap	CI	1
5	Bolt with nuts	MS	2



**Procedure:**

1. Model all the parts given in parts module & apply material as shown in the parts table.
2. Assemble the parts suitably using assembly module.
3. Draft the assembly, mark part numbers using balloons & take print of the same.
4. Note down the following values:
  - a. Total mass of the assembly = \_\_\_\_\_
  - b. Distance between centre of gravity of each part from its lowermost point when it is placed vertically? \_\_\_\_\_

**Precautions:**

1. Do not save your files on desktop or C drive. (They will be automatically erased on system restart.)
2. Save your file in the D drive in a folder of your name or roll number.
3. Don't install, uninstall or change any setting the system.
4. Don't tamper or exchange any hardware (mouse/keyboard etc)
5. Inform about any malfunctions to the instructor right away.

**Viva Questions:**

1. What are the applications of Eccentrics?
2. What type of fitting is used between the following pairs & why?
  - a. Base bearing brass
  - b. Bearing brass & shaft
  - c. Base & cap
3. What is the total mass of the assembly after applying the materials mentioned in the Parts Table? \_\_\_\_\_
4. What is the height of centre of gravity of each part from its lowermost point when it is placed vertically? \_\_\_\_\_

## EXPERIMENT: 12

### Screw Jack

**Aim:**

To model the screw Jack assembly from given dimensions using available CAD package.

**Apparatus:**

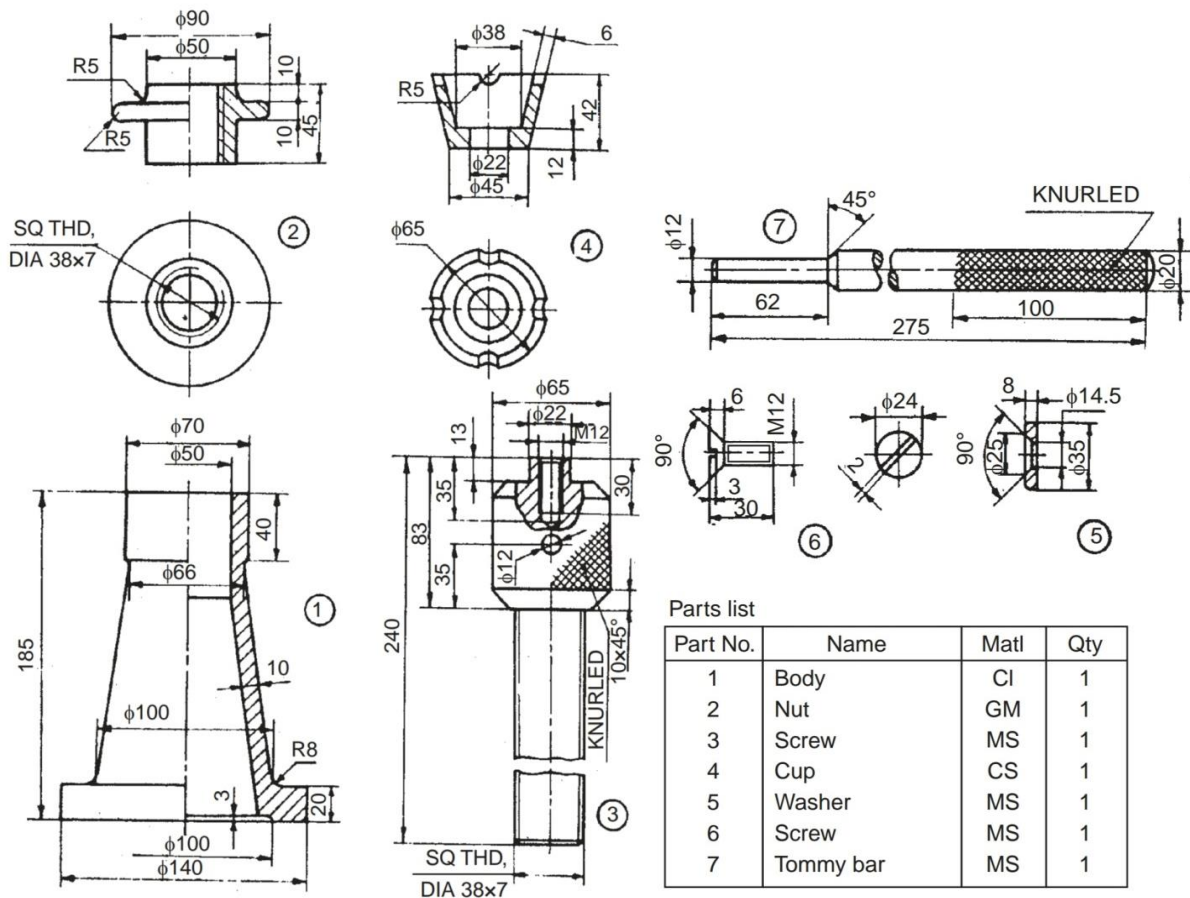
Hardware: Desktop System with i3 processor, 8 GB RAM, Graphics Card & 250 GB HDD.  
Software: Windows 7 64-bit OS, \_\_\_\_\_ Package.

**Commands / Features used (in following modules):**

Sketcher: Line, Circle, Construction Geometry, Dimensioning, Constraints  
Part: Extrude, Revolve, Add, Subtract  
Assembly: Axis coincidence  
Drawing: Insert View, Insert Projection, Generate Sectional View, Dimensioning

**Question & Part Details:**

6. Complete the following tasks using Solidworks,
  - a. Model all the parts given below in part module.
  - b. Assemble all the parts using assembly module.
  - c. Generate the half sectional front view, Top View & side view of the assembly using drawing module. Also generate the Bill of Materials & number the parts shown in the assembly using balloons.



**Procedure:**

1. Model all the parts given in parts module & apply material as shown in the parts table.
2. Assemble the parts suitably using assembly module.
3. Draft the assembly, mark part numbers using balloons & take print of the same.
4. Note down the following values:
  - a. Total mass of the assembly = \_\_\_\_\_
  - b. Distance between centre of gravity of each part from its lowermost point when it is placed vertically? \_\_\_\_\_

**Precautions:**

1. Do not save your files on desktop or C drive. (They will be automatically erased on system restart.)
2. Save your file in the D drive in a folder of your name or roll number.
3. Don't install, uninstall or change any setting the system.
4. Don't tamper or exchange any hardware (mouse/keyboard etc)
5. Inform about any malfunctions to the instructor right away.

**Viva Questions:**

1. What are the applications of Eccentrics?
2. What type of fitting is used between the following pairs & why?
  - a. Body & Nut
  - b. Nut & screw
  - c. Cup & Screw
  - d. Tommy Bar & Screw
3. What is the total mass of the assembly after applying the materials mentioned in the Parts Table? \_\_\_\_\_
4. What is the height of centre of gravity of each part from its lowermost point when it is placed vertically? \_\_\_\_\_

### EXPERIMENT: 13

#### Connecting Rod

**Aim:**

To model the Connecting Rod assembly from given dimensions using available CAD package.

**Apparatus:**

Hardware: Desktop System with i3 processor, 8 GB RAM, Graphics Card & 250 GB HDD.

Software: Windows 7 64-bit OS, \_\_\_\_\_ Package.

**Commands / Features used (in following modules):**

Sketcher: Line, Circle, Construction Geometry, Dimensioning, Constraints

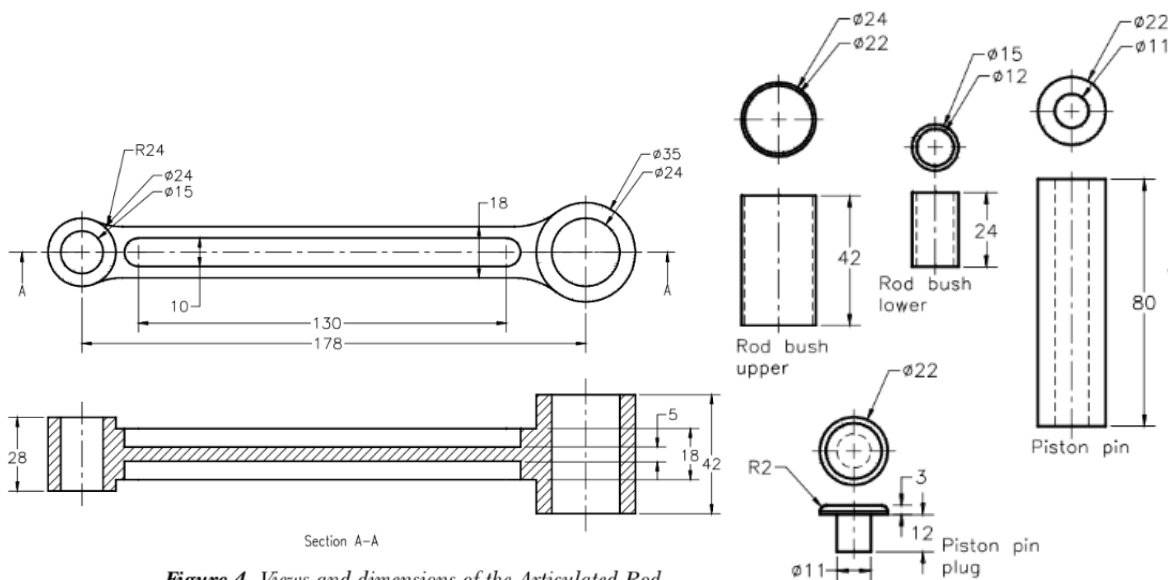
Part: Extrude, Revolve, Add, Subtract

Assembly: Axis coincidence

Drawing: Insert View, Insert Projection, Generate Sectional View, Dimensioning

**Question & Part Details:**

7. Complete the following tasks using Solidworks,
  - a. Model all the parts given below in part module.
  - b. Assemble all the parts using assembly module.
  - c. Generate the half sectional front view, Top View & side view of the assembly using drawing module. Also generate the Bill of Materials & number the parts shown in the assembly using balloons.



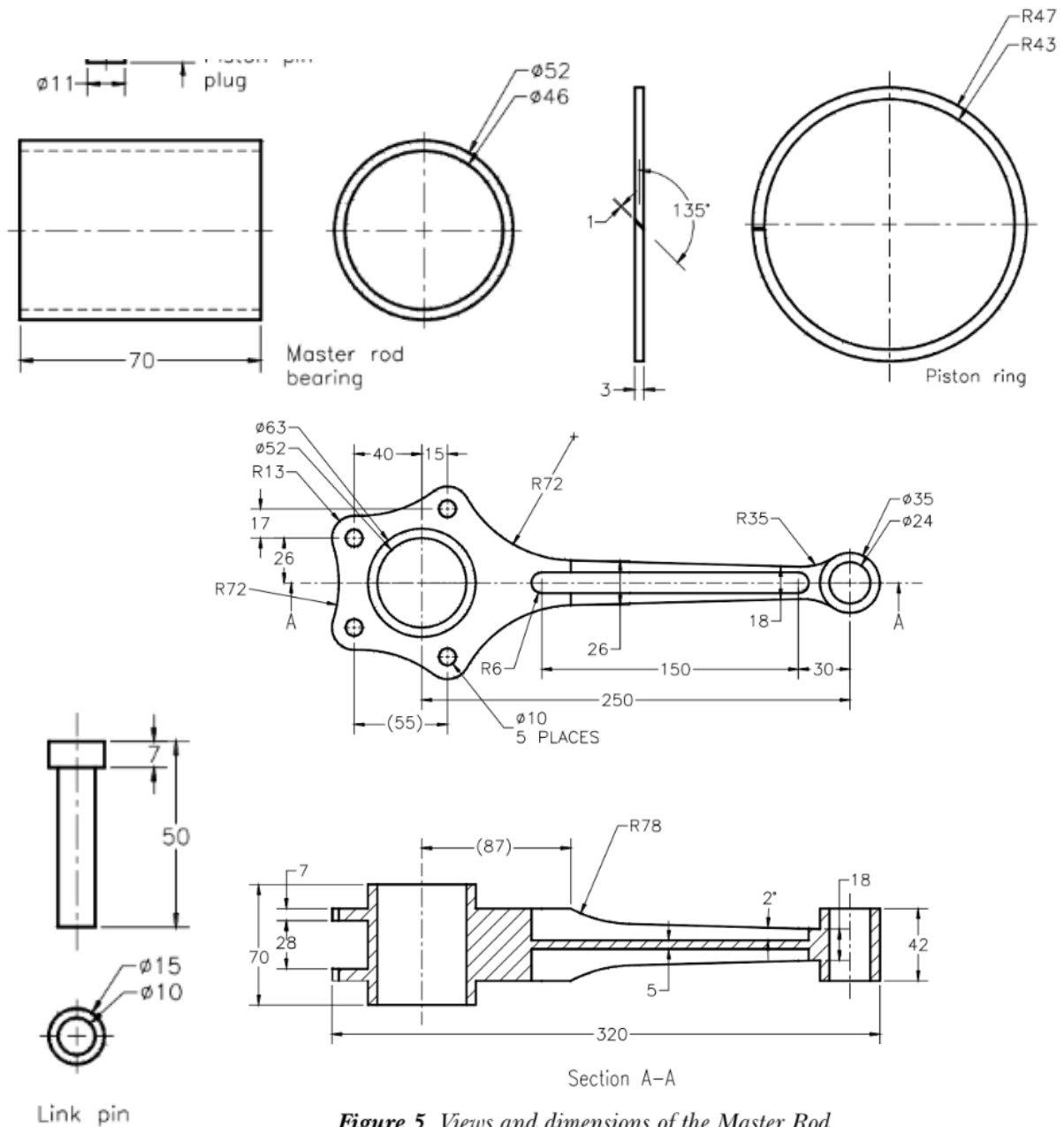


Figure 5 Views and dimensions of the Master Rod

**Procedure:**

1. Model all the parts given in parts module & apply material as shown in the parts table.
2. Assemble the parts suitably using assembly module.
3. Draft the assembly, mark part numbers using balloons & take print of the same.
4. Note down the following values:
  - a. Total mass of the assembly = \_\_\_\_\_
  - b. Distance between centre of gravity of each part from its lowermost point when it is placed vertically? \_\_\_\_\_

**Precautions:**

1. Do not save your files on desktop or C drive. (They will be automatically erased on system restart.)
2. Save your file in the D drive in a folder of your name or roll number.
3. Don't install, uninstall or change any setting the system.

4. Don't tamper or exchange any hardware (mouse/keyboard etc)
5. Inform about any malfunctions to the instructor right away.

**Viva Questions:**

1. What are the applications of Eccentrics?
2. What is the total mass of the assembly after applying the materials mentioned in the Parts Table? \_\_\_\_\_
3. What is the height of centre of gravity of each part from its lowermost point when it is placed vertically? \_\_\_\_\_

## EXPERIMENT: 14

### Rotating Centre

**Aim:**

To model the Rotating Centre assembly from given dimensions using available CAD package.

**Apparatus:**

Hardware: Desktop System with i3 processor, 8 GB RAM, Graphics Card & 250 GB HDD.

Software: Windows 7 64-bit OS, \_\_\_\_\_ Package.

**Commands / Features used (in following modules):**

Sketcher: Line, Circle, Construction Geometry, Dimensioning, Constraints

Part: Extrude, Revolve, Add, Subtract

Assembly: Axis coincidence

Drawing: Insert View, Insert Projection, Generate Sectional View, Dimensioning

**Question & Part Details:**

8. Complete the following tasks using Solidworks,
  - a. Model all the parts given below in part module.
  - b. Assemble all the parts using assembly module.
  - c. Generate the half sectional front view, Top View & side view of the assembly using drawing module. Also generate the Bill of Materials & number the parts shown in the assembly using balloons.

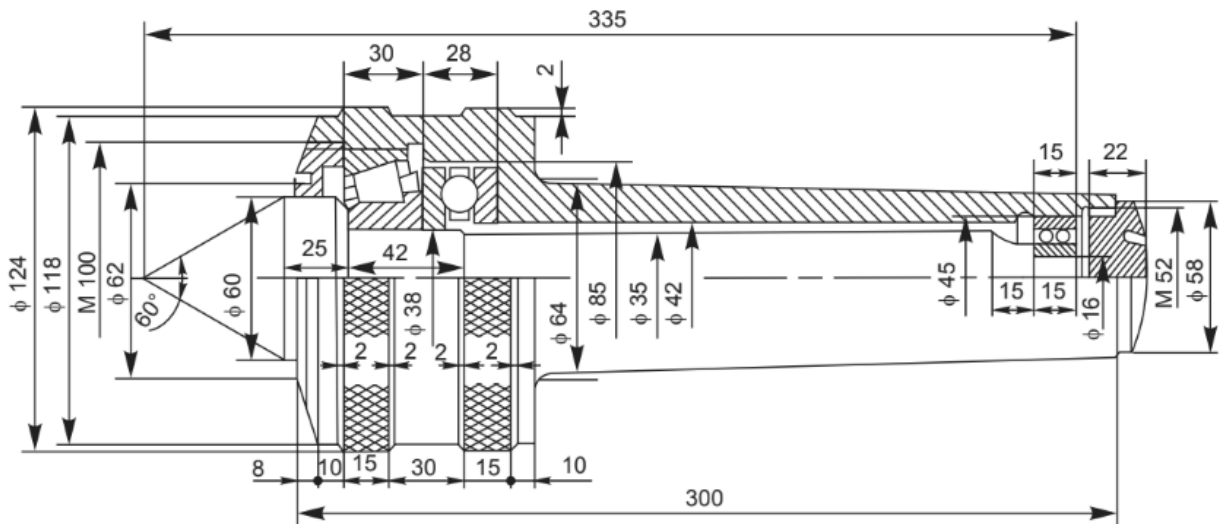


Fig. 12.17 Revolving center

**Procedure:**

1. Model all the parts given in parts module & apply material as shown in the parts table.
2. Assemble the parts suitably using assembly module.
3. Draft the assembly, mark part numbers using balloons & take print of the same.
4. Note down the following values:
  - a. Total mass of the assembly = \_\_\_\_\_



- b. Distance between centre of gravity of each part from its lowermost point when it is placed vertically? \_\_\_\_\_

**Precautions:**

1. Do not save your files on desktop or C drive. (They will be automatically erased on system restart.)
2. Save your file in the D drive in a folder of your name or roll number.
3. Don't install, uninstall or change any setting the system.
4. Don't tamper or exchange any hardware (mouse/keyboard etc)
5. Inform about any malfunctions to the instructor right away.

**Viva Questions:**

1. What are the applications of Eccentrics?
2. What is the total mass of the assembly after applying the materials mentioned in the Parts Table? \_\_\_\_\_
3. What is the height of centre of gravity of each part from its lowermost point when it is placed vertically? \_\_\_\_\_



**Estd: 2008**

# **METHODIST**

## **COLLEGE OF ENGINEERING & TECHNOLOGY**

**Approved by AICTE New Delhi | Affiliated to Osmania University, Hyderabad**  
Abids, Hyderabad, Telangana, 500001