



Estd: 2008

METHODIST

COLLEGE OF ENGINEERING & TECHNOLOGY

Approved by AICTE New Delhi | Affiliated to Osmania University, Hyderabad

Abids, Hyderabad, Telangana, 500001

DEPARTMENT OF MECHANICAL ENGINEERING

LABORATORY MANUAL

**METALLURGY AND
MATERIAL TESTING LAB**

BE III Semester

For the Students admitted in AICTE Scheme

Name:

Roll No:

Branch:.....SEM:.....

Academic Year:



Estd: 2008

METHODIST

COLLEGE OF ENGINEERING & TECHNOLOGY

Approved by AICTE New Delhi | Affiliated to Osmania University, Hyderabad
Abids, Hyderabad, Telangana, 500001

VISION

To produce ethical, socially conscious and innovative professionals who would contribute to sustainable technological development of the society.

MISSION

To impart quality engineering education with latest technological developments and interdisciplinary skills to make students succeed in professional practice.

To encourage research culture among faculty and students by establishing state of art laboratories and exposing them to modern industrial and organizational practices.

To inculcate humane qualities like environmental consciousness, leadership, social values, professional ethics and engage in independent and lifelong learning for sustainable contribution to the society.



Estd: 2008

METHODIST

COLLEGE OF ENGINEERING & TECHNOLOGY

Approved by AICTE New Delhi | Affiliated to Osmania University, Hyderabad

Abids, Hyderabad, Telangana, 500001

DEPARTMENT OF MECHANICAL ENGINEERING

LABORATORY MANUAL

METALLURGY AND MATERIAL TESTING LAB (PC 251 ME)

Prepared by

PART-A

Dr. A. Rajasekhar, Professor & Head, Mech. Engg.

Mrs. I. Sowjanya, Assistant Professor, Mech. Engg.

PART-B

Mr. Y. Madhu M. Reddy, Assistant Professor, Mech. Engg.

Mr. V. Durgesh, Assistant Professor, Mech. Engg.

DEPARTMENT OF MECHANICAL ENGINEERING

VISION

To be a reputed centre of excellence in the field of mechanical engineering by synergizing innovative technologies and research for the progress of society.

MISSION

- To impart quality education by means of state-of-the-art infrastructure.
- To involve in trainings and activities on leadership qualities and social responsibilities.
- To inculcate the habit of life-long learning, practice professional ethics and service the society.
- To establish industry-institute interaction for stakeholder development.

DEPARTMENT OF MECHANICAL ENGINEERING

After 3-5 years of graduation, the graduates will be able to:

PEO1: Excel as engineers with technical skills, and work with complex engineering systems.

PEO2: Capable to be entrepreneurs, work on global issues, and contribute to industry and society through service activities and/or professional organizations.

PEO3: Lead and engage diverse teams with effective communication and managerial skills.

PEO4: Develop commitment to pursue life-long learning in the chosen profession and/or progress towards an advanced degree

DEPARTMENT OF MECHANICAL ENGINEERING

PROGRAM OUTCOMES

Engineering Graduates will be able to:

PO1. Engineering knowledge: Apply the basic knowledge of mathematics, science and engineering fundamentals along with the specialized knowledge of mechanical engineering to understand complex engineering problems.

PO2. Problem analysis: Identify, formulate, design and analyse complex mechanical engineering problems using knowledge of science and engineering.

PO3. Design/development of solutions: Develop solutions for complex engineering problems, design and develop system components or processes that meet the specified needs with appropriate consideration of the public health and safety, and the cultural, societal, and environmental considerations.

PO4. Conduct investigations of complex problems: Formulate engineering problems, conduct investigations and solve using research-based knowledge.

PO5. Modern tool usage: Use the modern engineering skills, techniques and tools that include IT tools necessary for mechanical engineering practice.

PO6. The engineer and society: Apply the contextual knowledge to assess societal, health, safety, legal and cultural issues and the consequent responsibilities relevant to the professional engineering practice.

PO7. Environment and sustainability: Understand the impact of the professional engineering solutions in societal and environmental contexts, and demonstrate the knowledge of, and need for sustainable development.

PO8. Ethics: Apply ethical principles and commit to professional ethics and responsibilities during professional practice.

PO9. Individual and team work: Function effectively as an individual, and as a member or leader in diverse teams, and in multidisciplinary settings.

PO10. Communication: Communicate effectively on complex engineering activities to various groups, ability to write effective reports and make effective presentations.

PO11. Project management and finance: Demonstrate and apply the knowledge to understand the management principles and financial aspects in multidisciplinary environments.

PO12. Life-long learning: Recognize the need for, and have the preparation and ability to engage in independent and life-long learning in the broadest context of technological change.

PROGRAM SPECIFIC OUTCOMES

Mechanical Engineering Graduates will be able to:

PSO1: Apply the knowledge of CAD/CAM/CAE tools to analyse, design and develop the products and processes related to Mechanical Engineering.

PSO 2: Solve problems related to mechanical systems by applying the principles of modern manufacturing technologies.

PSO 3: Exhibit the knowledge and skill relevant to HVAC and IC Engines.

CODE OF CONDUCT

1. Students should report to the concerned labs as per the time table schedule.
2. Students who turn up late to the labs will in no case be permitted to perform the experiment scheduled for the day.
3. After completion of the experiment, certification of the concerned staff in-charge in the observation book is necessary.
4. Staff member in-charge shall award marks based on continuous evaluation for each experiment out of maximum 15 marks and should be entered in the evaluation sheet/attendance register.
5. Students should bring a note book of about 100 pages and should enter the readings/observations into the note book while performing the experiment.
6. The record of observations along with the detailed experimental procedure of the experiment performed in the immediate last session should be submitted and certified by the staff member in-charge.
7. Not more than three students in a group are permitted to perform the experiment on a setup for conventional labs and one student in case of computer labs.
8. The components required pertaining to the experiment should be collected from stores in-charge after duly filling in the requisition form.
9. When the experiment is completed, students should disconnect the setup made by them, and should return all the components/instruments taken for the purpose.
10. Any damage of the equipment or burn-out of components will be viewed seriously either by putting penalty or by dismissing the total group of students from the lab for the semester/year.
11. Students should be present in the labs for the total scheduled duration.
12. Students are required to prepare thoroughly to perform the experiment before coming to Laboratory.

DO'S

1. All the students are instructed to wear protective uniforms, shoes & identity cards before entering into the laboratory.
2. Please follow instructions precisely as instructed by your supervisor. If any part of the equipment fails while being used, report it immediately to your supervisor.
3. Students should come with thorough preparation for the experiment to be conducted.
4. Students will not be permitted to attend the laboratory unless they bring the practical record fully completed in all respects pertaining to the experiment conducted in the previous class.
5. Practical records should be neatly maintained.
6. Students should obtain the signature of the staff-in-charge in the observation book after completing each experiment.
7. Utmost care must be taken to avert any possible injury while working on Whirling of shafts. In case, anything occurs immediately report to the staff members.
8. Enter or Leave the lab only with the permission of lab in-charge.

DON'TS

1. Don't operate any instrument without getting concerned staff member's prior permission.
2. Using the mobile phone in the laboratory is strictly prohibited.
3. Do not leave the experiments unattended while in progress.
4. Do not crowd around the equipment & run inside the laboratory.
5. Do not wander around the lab and distract other students
6. Do not use any machine that smokes, sparks, or appears defective.

COURSE OBJECTIVES

The objectives of this course are to:

1.	Acquire basic knowledge by understanding iron-carbide diagram and its application in engineering
2.	Expose to Metallographic study and analysis of various metals.
3.	Acquires knowledge in determining the hardness of metals before and after various Heat treatment operations.
4.	Understand differences between different heat treatment methods.
5.	Understand the relation between micro structure and properties

COURSE OUTCOMES

CO No.	Course Outcomes	PO
CO 1	Apply the procedure for preparing the sample for metallographic observation.	1, 8, 9, 10 & 12
CO 2	Identify different materials by examining the phases in their micro structure.	1, 5, 8, 9, 10 & 12
CO 3	Analyze the effects of various heat treatment by studying the grain structure	1, 2, 3, 4, 5, 8, 9, 10 & 12.
CO 4	Determine the tensile, compressive and impact strength for various materials	1, 3, 4, 8, 9, 10 & 12.
CO 5	Measure hardness, shear strength and check their suitability for a given design requirement.	1, 3, 4, 8, 9, 10 & 12.
CO 6	Determine the Shear force, bending moment and Young's modulus of different beams under various loading conditions.	1, 3, 8, 9, 10 & 12.

COURSE OUTCOMES VS POs MAPPING

S.NO	PO1	PO2	PO3	PO4	PO5	PO6	PO7	PO8	PO9	PO10	PO11	PO12	PSO1	PSO2	PSO3
C209.1	3	-	-	-	-	-	-	1	1	1	-	1	-	1	-
C209.2	3	-	-	-	1	-	-	1	1	1	-	1	-	1	-
C209.3	3	3	1	2	2	-	-	1	1	1	-	1	-	1	-
C209.4	3	-	2	3	-	-	-	1	1	1	-	1	1	-	-
C209.5	3	-	2	3	-	-	-	1	1	1	-	1	1	-	-
C209.6	3	-	2	-	-	-	-	1	1	1	-	1	1	-	-
C209.1	3	3	1.7	2.6	1.5			1	1	1		1	1	1	

LIST OF EXPERIMENTS

Exp. No.	Experiment Name	Page No.
1.	Study of: Metallurgical Microscope, Iron-Iron Carbide diagram, Procedure for specimen preparation	2-12
2.	Metallographic Study of Pure Iron & Low carbon steel	13-17
3.	Metallographic Study of Medium carbon steel, Eutectoid steel & Hyper Eutectoid steel	18-21
4.	Metallographic Study of Grey cast-iron, White cast-iron, & Black heart Malleable cast iron	22-26
5.	Metallographic Study of Aluminium, Brass & Bronze	27-31
6.	Jominy Quench test or Study of microstructure after heat treatment	32-36
7.	Uni-axial tension test, to draw stress-strain diagram, and estimate modulus of elasticity and % of elongation	39-46
8.	Compression test on bricks and Impact test	47-54
9.	Hardness test: Brinell	55-62
10.	Shear force & Bending moment tests.	63-67
11.	Bending test on fixed beam, simply supported beam	68-75
12.	Spring Test and Torsion Test	76-88

LIST OF ADDITIONAL EXPERIMENTS

1.	Rockwell Hardness Tester	89-94
2.	Deflection Test on Cantilever Beam	95-101
3.	Fatigue Test	102-107

Note: At least ten experiments should be conducted in the Semester

PART-A

METALLURGY LAB

EXPERIMENT –01

STUDY OF METALLURGICAL MICROSCOPE, IRON-IRON CARBIDE DIAGRAM, SPECIMEN PREPARATION

AIM: - To study the working principle of a Metallurgical Microscope, Procedure for mounting and preparation of a Specimen for metallographic examination and Iron-Iron carbide diagram

METALLURGICAL MICROSCOPE: -

Principle: - A horizontal beam of light from the light source is reflected by means of a plane glass reflector downwards through the microscope objective on the surface of the specimen some of this incident light reflected from the specimen surface will be magnified and passing through the plane glass reflector and magnified again by upper lens system of the eye-piece.

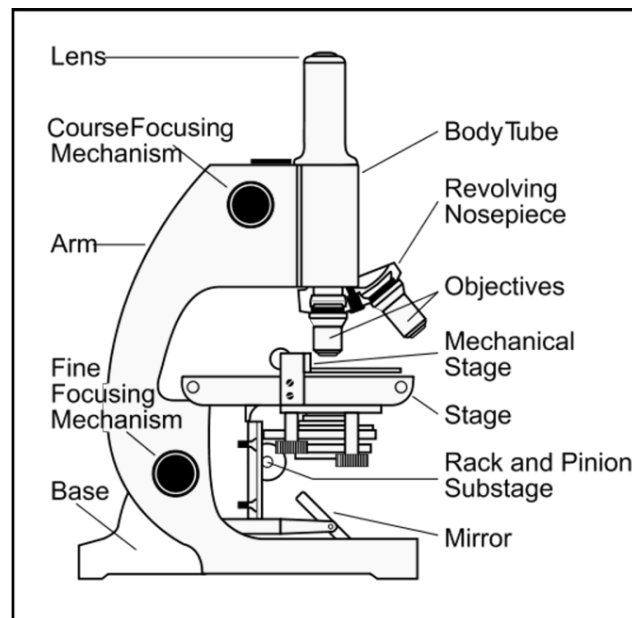

Fig: - Metallurgical Microscope

THEORY: - The science of metallography is essentially the study of the structural characteristic of a constitution of a metal/alloy in relation to the physical and mechanical properties.

Metallography consists of macroscopy and microscopy. Macroscopic examination involves study of metal either by naked eye or with the aid of low magnification (<10X). This type of examination reveals some of the important details such as uniformity of structure and presence of defects.

Construction and Working of Metallurgical Microscope: -

A metallurgical microscope consists of a stand, to which a movable tube is attached containing the optical parts of the microscope, and a device for illuminating the specimen. Light from an electrical bulb falls on a glass reflector kept at 45° to the vertical axis in the movable tube. These light rays get reflected vertically downwards, travel through the objective, and fall on the specimen. The light reflected by flat and polished specimen surface travel through the objective and transparent portion of glass plate and come to the eye piece. The image can be observed through the eye piece, or these rays can be focused on a screen and image can be observed.

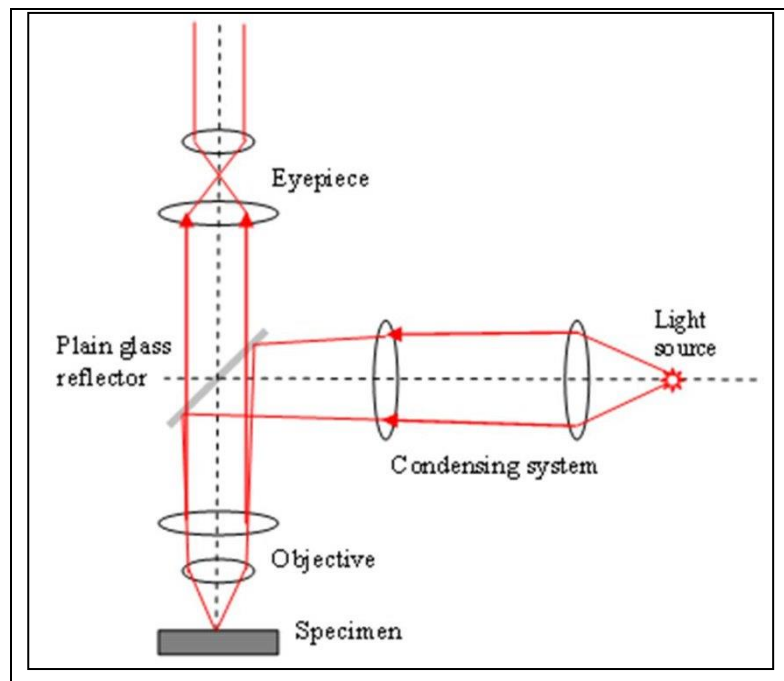

Fig: - Optical features of metallurgical microscope

Some important terms related to all optical metallurgical microscopes are –

a) Magnifying power of objective: -

It is the ability of an objective to magnify the real object by definite number of times without the aid of an eye-piece. The is engraved on the objective mount objective are available with magnifying powers of 5X, 10X, 40X, 50X, 90X or 100X (X sign denotes linear magnification)

b) Magnifying power of eye-piece: -

It is the ability of an eye-piece to magnifying the real object by definite number of turns. This is engraved on the eye-piece mount. Eye-pieces are available with magnifying powers 5X, 10X, 15X, 20X, or 25X.

The total magnification obtained by the combination of given eye-piece and objective depends not only on initial magnifying power but also on the distance by which these two are separated in the microscope. Almost all the objectives are designed for use at a definite tube length, which is about 250mm. When a given combination of objective and eye-piece is used at appropriate tube length. The total magnification is the product of their initial magnification. When the image is projected onto a screen, total magnification is given by $M = D * (M_1 M_2) / 250x$.

M = Magnification on screen,

M_1 = Magnification of objective

M_2 = Magnification of eye piece and

D = Projection distance i.e., the distance from the eye lens of eye piece to the screen in mm.

c) Numerical aperture of the objects:

It is the light collection or light gathering capacity of an objective. It is constant for a given objective and is a function of a design.

Numerical Aperture = $n \sin \mu$

n = refractive index of the immersion medium between objective and specimen

μ = one-half of the objective's opening angle

d) Resolving Power (or) Resolving of an objective: -

It is the ability of an objective to produce sharply defined separate images of closely spaced details in the object. Fineness of details or limit of resolution is the minimum clearance distance that can be seen clearly by that objective at some suitable magnification for a narrow beam of light

Finess details or resolution limit = λ / NA

Where $\lambda \rightarrow$ wave length of illumination

NA \rightarrow numerical aperture of the objective

Resolving power or resolution is inversely proportional to the fineness detail.

Resolving power of a given microscope can be increased by using visible light beam of smaller wave length and by oil immersion objective. Desired light can be obtained by inserting an appropriate filter in the illumination screen.

Uses: The metallurgical microscope is useful in quality control department in Industries to observe & study 1) Differential phases 2) Porosity or defects.

MOUNTING OF SPECIMEN: -

Specimens that are very small or awkwardly shaped should be mounted to favourite, intermediate & final polishing wires small rods steel, sheet metal specimens, thin sections etc. must be approximately mounted in a suitable material or rigidly damped in a mechanical mount Synthetic plastic materials applied in a special mounting press will yield amount of uniform convenient size (usually 1 inch or 1.25 inch or 1.5 inch. in diameter) for handling in subsequent polishing operation. This mounts when properly made are very resistant to attack by etching reagent ordinarily used. The most common thermosetting resin for mounting is 'Bakelite'. Bakelite molding powders are available in variety of colors which simplifies the identification of mounted specimen. The specimen & the correct amount of Bakelite powder is available in variety of cloves which simplifies the identification of mounted specimen. The specimen & the correct amount of Bakelite powder is placed in the cylinder of the mounting press. The temperature is gradually 150°C & a molding pressure of about 4000 PSI is applied simultaneously. Since Bakelite is set & curved when this temperature is reached, the specimen mount may be ejected from the molding die which is still hot.

Lucite is the most common thermosetting plastic resin for mounting. It is completely transparent when properly mounted. This transparency is useful when it is polished or when it is desirable for any other reason to see the entire specimen in the mould mount unlike the thermosetting plastic, the thermosetting resin don't undergo curing at the molding temperature, rather they set on cooling. The specimen & a proper amount of Lucite powder are placed in the mounting press & are subjected to the same temperature & pressure as for Bakelite (150° C, 4000PSI). After this has been reached, the heating coil is removed & cooling fins are placed around the cylinder to cool the mount to about 75°C in about 7 minutes while the molding pressure is maintained. Then the mount be ejected from the mould. Ejecting the mount while still hot, or allowing it to cool slowly in the molding cylinder to ordinary temperature before ejection will cause mount to remain

opaque. Small specimens may be continuously mounted for metallographic preparation in a laboratory made damping device. Thin sheet specimens when mounted in a damping device, are usually alternated with metal. 'Filler' sheet which have approximately the same hardness as these specimens. The use of filler sheet will preserve surface irregularities of the specimen & will prevent to some extent the edges of the specimen from becoming rounded during polishing.

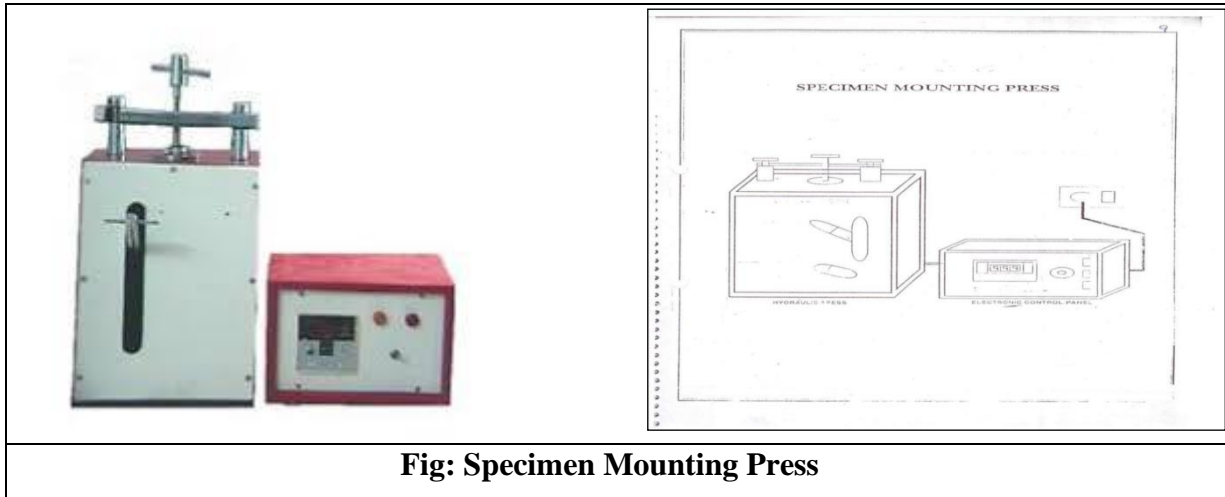

Fig: Specimen Mounting Press

PROCEDURE FOR SPECIMEN PREPARATION: -

Introduction: -

Metallographic study consists of the microscopic study of the structural characteristics of material or an alloy. The microscope is thus the most important tool of a ***metallurgist*** from both, scientific & technical study point view. It is possible to determine grain size & the size, shape & distribution of various phases & inclusions which have a great effect on the mechanical properties of metal. The microstructure will reveal the mechanical & thermal treatment of the metal & it may be possible to predict its behaviour under a given set of conditions.

Experience had indicated the success in microscopic study depends upon the care taken in the preparation of specimen. The most expensive microscope will not reveal the structure of a specimen that has been poorly revealed. The procedure to be followed in the preparation of a specimen is comparatively similar and simple & involves a technique which is developed only after constant practice. The ultimate objective is to produce a flat, scratch free, mirror like surface. The steps required to prepare a metallographic specimen properly are covered in the coming section explained below.

Sampling: -

The choice of sample for microscopic study may be very important. If a failure is to be investigated the sampling should be chosen as close as possible to the area of the failure & should be compared with one taken from the normal section. If the material is soft, such as non-ferrous metals or alloy & non heat treated steels, the section is obtained by manual hack sawing

/power saw. If the material is hard, the section may be obtained by use of an abrasive cut off wheels. This wheel is thin disk of suitable cutting abrasive rotating at high speed. The specimen should be kept cool during the cutting operation.

Rough Polishing: -

Whenever possible the specimen should be of a size & shape that is convenient to handle. A soft sample may be made flat by slowly moving it up to & back across the surface of a flat smooth file. The surface to be examined is made plane using motor-driven emery belt and specimen kept cool by frequent dipping in water during the grinding operation. In all grinding and polishing operation the specimen should be moved perpendicular to the existing scratches this will facilitate, recognition of stage when the deeper scratches are replaced by shallower one characteristic of the finer abrasives. The rough grinding is continued until the surface is flat & free from wire brushes & all scratches due to hacksaw or cut-off wheel are no longer visible.

Intermediate Polishing: -

After the previous processes the specimen is polished on a series of emery paper containing successively finer abrasive (Si-C). The first paper is usually no. 1 than 1/0, 2/0, 3/0, & finally 4/0. The intermediate polishing operation using emery paper is usually done dry. However, in certain cases such as preparation of soft material, Silicon Carbide has greater removal rate & as it is resin bonded, can be used with a lubricant, which prevents overshooting of the sample, minimizes shearing of soft metals & also provides a rising action to flush away surface removal product so the paper won't be clogged.

Fine polishing: -

The time consumed & the success of fine polishing depends largely on the case that we exercised during the previous polishing processes. The final approximation to the flat, scratch free surface is obtained by the use of a wet rotating wheel covered with a special cloth that is charged by carefully sized abrasive particles. A wide range of abrasive is

available for final polishing, while many will do a satisfying job, these appear to be presence of gamma form of Aluminium-oxides (Al_2O_3), for ferrous & copper based materials & Cerium oxide for Aluminium, Magnesium & their alloys, other final polishing abrasives often used are diamond dust, chromium oxide & magnesium oxide etc. A choice of proper polishing cloth depends upon the particular material being polished & the purpose of metallographic study. The cloth may be Selvyt, Velvyt, Microcloth or Miracloth. A cloth to be used for the first time is soaked in water and in wet condition, it is stretched tightly over the lapping wheel and firmly clamped.

Etching: -

The purpose of etching is to make the many structural characteristics of the metal or alloy visible. The process should be such that the various parts of the microstructure may be clearly differentiated. This is to subject the polished surface to chemical action. In the alloys composed of two or more shapes. The components are revealed during etching by a preferential attack of one or more of the constituents by the reagent because of difference in chemical composition of the phases. In uniform single phase alloy contact is obtained and the grain boundaries are made visible because of difference in the rate at which various grains are attacked by the reagent.

This difference in the rate of attack by reagent which is mainly associated with angle of the different grain structure section to the plane of the polished surface. Because of chemical attack of the chemical reagent the grain boundary appears as valleys in the polished surface light from the microscope hitting the side of these valleys will be reflected but of the microscope making the grain boundaries appears dark lines. The selection of the appropriate etching reagent is determined by metal or alloys & the specific structure desired for viewing.

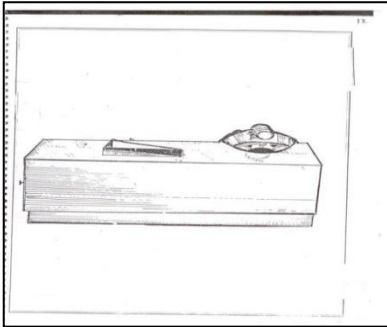
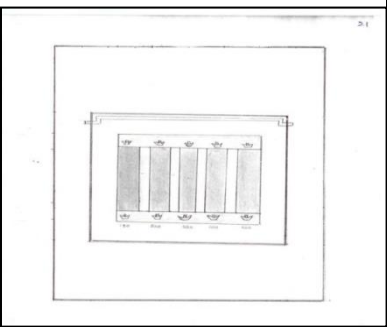
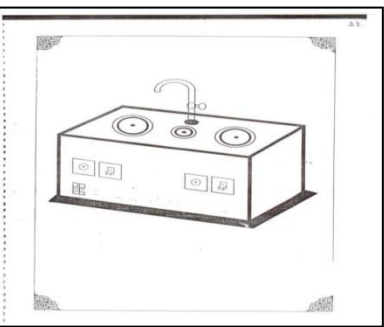
		
Belt Grinding Machine	Plate Polishing Machine	Disc Polishing Machine

Etching reagents are applied to the polished surface of a specimen by means of either immersion or swabbing technique. In immersion technique, the specimen is dipped into the etchant by means of tongs and agitated moderately without touching the bottom surface of the container. In swabbing, the polished surface is swabbed with a soft cotton saturated with etchant. After etching, sample is quickly washed in running water, rinsed in ethyl alcohol and dried in a blast of warm air. The etched specimen is now observed under the microscope at the desired magnification. The following are the some of the commonly used etchants.

Etchant	Composition	Concentration	Conditions	Comments
Nital	Ethanol Nitric acid	100 ml 1-10 ml	Immersion from a few seconds to minutes	Most common etchant for Fe, carbon and alloy steels and cast iron
Keller's Reagent	Distilled water Nitric acid Hydrochloric acid Hydrofluoric acid	190 ml 5 ml 3 ml 2 ml	10-30 second immersion. Use only fresh etchant	Excellent for Aluminium and Titanium alloys
Copper No.1	Nitric acid Distilled water	125 ml 125 ml	1 second to several minutes by immersion or swabbing	Common etchant for copper and copper alloys such as brass, bronze

IRON-IRON CARBIDE DIAGRAM: -

Iron can exist in three different crystalline forms each having limited solubility of carbon. The stability of these depends on temperature and composition. The two high temperature forms of iron are δ ferrite which is BCC (stable above 1394°C) and austenite (γ : stable above 910°C) which is FCC. The room temperature form of iron is α ferrite which is BCC. The solubility of carbon in ferrite is limited. The maximum solubility is around 0.025wt% as against this the solubility of carbon in austenite is a little more. It is about 2wt%. Apart from this iron carbon system may have iron carbide (Fe_3C) called cementite. It has 6.67 wt%. carbon. It is considered as an inter-metallic compound having relatively more complex crystal structure than those of ferrite and austenite. It is a meta-stable phase. It may exist for indefinite periods of time at room temperature. However, on prolonged thermal exposure at 600°C or beyond it transforms into ferrite and graphite. Therefore, iron carbon alloys of commercial importance may be considered as a binary alloy of iron and cementite. Let us first look at its phase diagram. It is also known as iron cementite meta-stable phase diagram. Although it is a binary system there are 5 different phases including the liquid. This is likely to have more than one invariant reaction involving 3 phases.

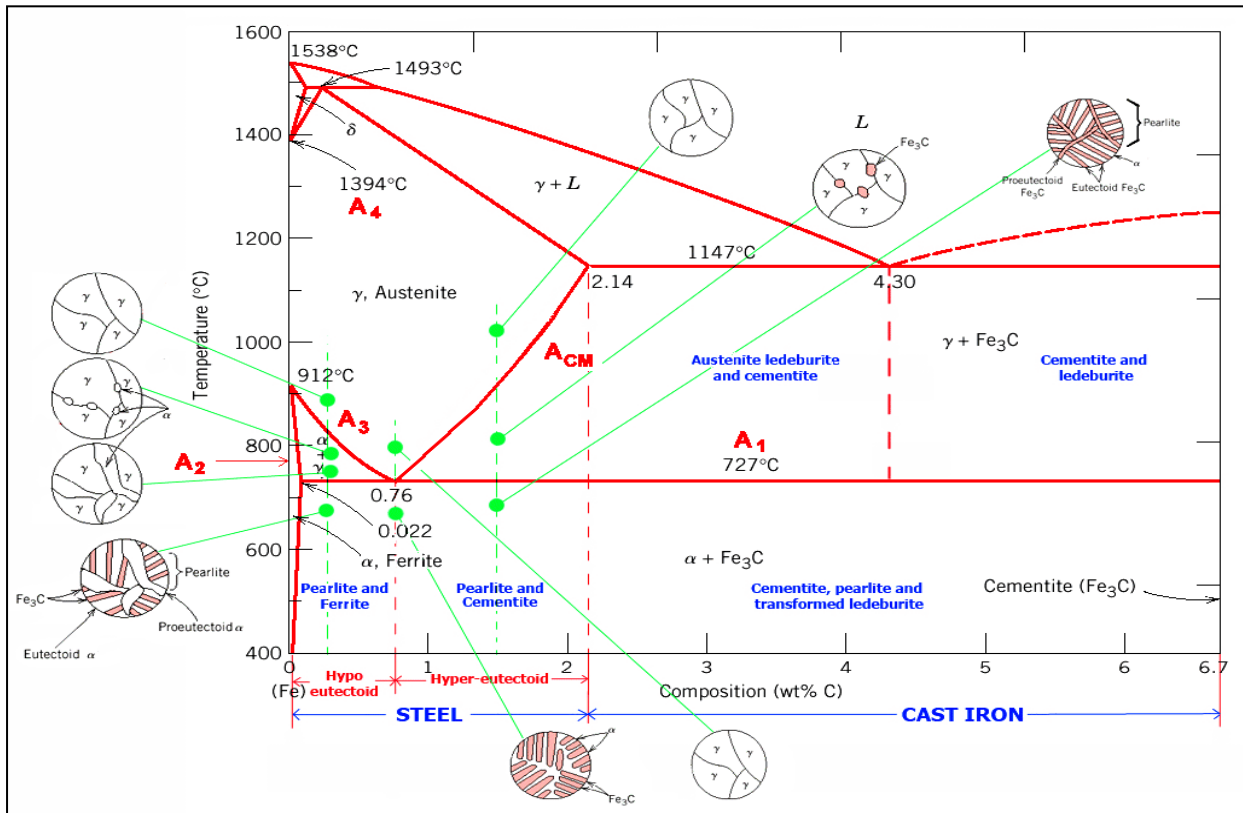

Figure shows a Fe-Fe₃C phase diagram. It has 3 invariant reactions (transformation). The one occurring at 1495°C is the peritectic reaction. The delta ferrite reacts with liquid to form austenite. The one at 1147°C is known as the eutectic reaction where the liquid transforms into a mixture of austenite and cementite. The eutectic mixture of austenite and cementite is known as Ledeburite. The one at 727°C is known as eutectoid transformation where austenite decomposes into a mixture of ferrite and cementite. This is known as Pearlite. On the basis of this diagram iron – carbon alloys having less than 2.0% carbon are known as steel, whereas those having more than 2.0% carbon are known as cast iron. This classification is based on their ability to undergo large plastic deformation. Steel is ductile but cast iron is brittle.

RESULT & CONCLUSIONS: - Thus the Metallurgical Microscope, Procedure for Specimen preparation & mounting and iron-iron carbide diagram has been studied.

VIVA QUESTIONS

1. What is the use of micro study?
2. What is the difference among 1/0, 2/0, 3/0 and 4/0 emery papers?
3. What is lapping?
4. Why does the specimen have to be etched before lapping?
5. What are the different abrasives used in lapping?
6. Why does the specimen have to be etched before micro structural study?
7. What is the etchant used for mild steel? viii. In a microstructure how the grain boundary area appears?
8. Why specimen to be rotated through 90(between. Polishing on 1/0 and 2/0 emery papers?
9. What is etching reagent used for duralumin?
10. Why should a specimen be prepared following the set procedure before its observation under a microscope?

EXPERIMENT – 02

MICRO STRUCTURE OF LOW AND MEDIUM CARBON STEEL

AIM: - To prepare and study the Micro Structure of Low Carbon steel and Medium Carbon Steel.

APPARATUS / EQUIPMENT: -

- Abrasive Cut-Off Wheel Machine,
- Specimen Mounting Press
- Belt Grinding Machine.
- Double disc Polishing Machine.
- Metallurgical Microscope

Consumables/ Raw material: -

Rod or Sample pieces of Mild steel, Low carbon and Medium carbon steel, set of emery papers (220, 320, 400, 600, 1/0, 2/0, 3/0, and 4/0) Bakelite powder, lapping cloth, Alumina powder of different grades.

Etchant: Nital (100 ml ethanol, 1-10 ml Nitric acid)

THEORY: -

Mild Steel, Low Carbon steel, Medium Carbon Steel and High Carbon Steel are types of ferrous materials and are most important to the engineering application because of their wide range of properties and variety of applications. Theoretically, steels are the alloys of iron and carbon in which the carbon content is between 0.008 to 2.0 per cent. The properties and characteristics of steel are according to the carbon content present in it and there is a minor influence on this type of carbon due to the alloying and residual materials.

Plain carbon steel is subdivided into three groups

1. Low carbon steel
2. Medium carbon steel
3. High carbon steel

Low carbon steel: -

In low carbon steel the carbon content is less than 0.30 percent and is the most commonly used grades. They can be machined and welded nicely and their ductility is greater than high carbon steel. They are also called as Structural steels.

Medium carbon steel: -

In medium carbon steel the carbon content is from 0.30 to 0.60 percent carbon. Due to increased carbon content there is an increase in hardness and tensile strength and decrease in ductility and its machining and welding is difficult than low carbon steel due to increased content of carbon. They are also called as Machinery steels.

High carbon steel: -

In high carbon steel the carbon content is in between 0.6 to 1.5 percent. They are hard, wear resistant brittle, difficult to machine and weld. They are also called as Tool steels. The structures and properties can be discussed with the help of Fe-Fe₃C equilibrium diagram.

PROCEDURE: -

- **Selection of the Specimen:** It is essential that the specimen would be selected from the metal which can be representative of the whole mass.
- **Cutting of the Specimen:** The cutting of the selected metal is made with the help of a Saw of trepanning tool and an abrasive wheel for fine sizing.
- **Belt grinding:** One of the faces of the specimen is pressed against the emery belt of the belt grinder so that all scratches on the specimen surface are unidirectional.
- **Intermediate polishing:** The sample is to be polished on 220, 320, 400, 600, 800, 1/0, 2/0, 3/0, and 4/0 emery papers with increasing fineness of the paper. While changing the polish paper, the sample is to be turned by 90⁰ so that new scratches shall be exactly perpendicular to previous scratches.
- **Disc polishing (Fine polishing):** After polishing on 4/0 paper the specimen is to be polished on disc polishing machine. In the disc-polishing machine a disc is rotated by a vertical shaft. The disc is covered by a velvet cloth. Alumina

solution is used as an abrasive. Alumina solution is sprinkled continuously over the disc and specimen is gently pressed against it. In case of Non-Ferrous metal such as Brass, Brasso is used instead of Alumina and water. The polishing should be continued till a mirror polished surface is obtained.

- The sample is then washed with water and dried.
- **Etching:** The sample is then etched with a suitable etching reagent. After etching the specimen should be washed in running water and then with alcohol and finally dried.
- The sample is now ready for studying its microstructure under the microscope.

Precautions: -

- Grinding should be done on the emery papers only in one direction.
- While polishing the specimen uniform pressure should be exerted on the specimen.
- While going to the next grade of emery papers, the specimen has to be rotated through 90°.
- While switching over to new emery paper, specimen should be thoroughly washed with water to remove all loose particles.
- After etching the specimen should be washed away with in a few seconds.
- Operate the Microscope Knobs gently (without jerks)

RESULT & CONCLUSIONS: - Thus the microstructure of the given specimen has been studied.

VIVA QUESTIONS

1. What is Microscopy?
2. Why is it necessary to mount the specimen before grinding and polishing?
3. Which different etching agents are used for specimen preparations?
4. What is the principle of metallurgical Microscope?
5. How is the microstructure of pure Iron?
6. How is the microstructure of pure Copper?
7. How is the microstructure of pure aluminium?
8. How is the microstructure of low carbon steel?
9. How is the microstructure of medium carbon steel?
10. What is the purpose of Etching?
11. How will you identify cast iron, mild steel and high carbon steel?
12. What is High carbon steel?
13. What are the different alloying elements and their effects on the properties of the steel?

EXPERIMENT -03

MICRO STRUCTURE OF EUTECTOID STEEL AND HYPER EUTECTOID STEEL

AIM: - To prepare and study the Micro Structure of Eutectoid Steel and Hyper Eutectoid Steel.

APPARATUS / EQUIPMENT:

- Abrasive Cut-Off Wheel Machine,
- Specimen Mounting Press
- Belt Grinding Machine.
- Double disc Polishing Machine.
- Metallurgical Microscope

Consumables/ Raw material:

Rod or Sample pieces of Eutectoid Steel and Hyper Eutectoid Steel, set of emery papers (220, 320, 400, 600, 1/0, 2/0, 3/0, and 4/0) Bakelite powder, lapping cloth, Alumina powder of different grades.

Etchant: Nital (100 ml ethanol, 1-10 ml Nitric acid)

THEORY: -

Iron carbon alloy containing less than 2% carbon is called steel. Steels with 0.8% C are called eutectoid steels. Steels containing less than 0.8% carbon (eutectoid composition) are called hypo eutectoid steels and those containing between 0.8% and 2% are called hyper eutectoid steels.

PROCEDURE: -

- **Selection of the Specimen:** It is essential that the specimen would be selected from the metal which can be representative of the whole mass.
- **Cutting of the Specimen:** The cutting of the selected metal is made with the help of a Saw of trepanning tool and an abrasive wheel for fine sizing.

- **Belt grinding:** One of the faces of the specimen is pressed against the emery belt of the belt grinder so that all scratches on the specimen surface are unidirectional.
- **Intermediate polishing:** The sample is to be polished on 220, 320, 400, 600, 800, 1/0, 2/0, 3/0, and 4/0 emery papers with increasing fineness of the paper. While changing the polish paper, the sample is to be turned by 90° so that new scratches shall be exactly perpendicular to previous scratches.
- **Disc polishing (Fine polishing):** After polishing on 4/0 paper the specimen is to be polished on disc polishing machine. In the disc-polishing machine a disc is rotated by a vertical shaft. The disc is covered by a velvet cloth. Alumina solution is used as a abrasive. Alumina solution is sprinkled continuously over the disc and specimen is gently pressed against it. In case of Non-Ferrous metal such as Brass, Brasso is used instead of Alumina and water. The polishing should be continued till a mirror polished surface is obtained.
- The sample is then washed with water and dried.
- **Etching:** The sample is then etched with a suitable etching reagent. After etching the specimen should be washed in running water and then with alcohol and finally dried.
- The sample is now ready for studying its microstructure under the microscope.

Precautions: -

- Grinding should be done on the emery papers only in one direction.
- While polishing the specimen uniform pressure should be exerted on the specimen.
- While going to the next grade of emery papers, the specimen has to be rotated through 90° .
- While switching over to new emery paper, specimen should be thoroughly washed with water to remove all loose particles.
- After etching the specimen should be washed away with in a few seconds.
- Operate the Microscope Knobs gently (without jerks)

RESULT & CONCLUSIONS: - Thus the microstructure of the given specimen has been studied

VIVA QUESTIONS

1. What is the microstructure of hypo eutectoid steel?
2. What is the microstructure of hyper eutectoid steel?
3. How does carbon affect the properties of steel?
4. How is steel classified?
5. How will you identify cast iron, mild steel and high carbon steel?
6. What is High carbon steel?
7. What are the different alloying elements and their effects on the properties of the steel?
8. Which type of grains formed after hardening the steel?
9. What is the difference between Wrought iron, Cast iron and Pig iron?
10. Why is heat treatment of steel necessary?

EXPERIMENT- 04

MICROSTRUCTURES OF TYPES OF IRON

AIM: - To identify the different phases and to draw the microstructures of White Cast-iron, Grey Cast-iron and Malleable cast-iron.

APPARATUS / EQUIPMENT: -

- Abrasive Cut-Off Wheel Machine,
- Specimen Mounting Press
- Belt Grinding Machine.
- Double disc Polishing Machine.
- Metallurgical Microscope

Consumables/ Raw material: -

Rod or Sample pieces of white cast iron, set of emery papers (220, 320, 400, 600, 1/0, 2/0, 3/0, and 4/0) Bakelite powder, lapping cloth, Alumina powder of different grades.

Etchant: - Nital (100 ml ethanol, 1-10 ml Nitric acid)

THEORY: -

Cast irons are Iron carbon alloys in which carbon content varies from 2 to 6.67%. Cast irons that contain carbon percentage between 2 to 4.3% it is called hypo eutectic cast iron. If carbon content of cast iron is 4.3% it is called as eutectic cast iron. If the carbon content is above 4.3% it is called hyper eutectic cast iron. In white cast iron most of the carbon is present in combined form as cementite. This is obtained by rapidly cooling the cast iron from its molten state. These are hard and wear resistant. These are used only for hard and wear resistance applications and also used as raw material to produce malleable iron. At room temperature microstructure of Hypo Eutectic C.I consist of dendritic areas of transformed austenite in a matrix of transformed Ledeburite. At room temperature microstructure of eutectic cast iron consists of cementite and pearlite. At room temperature microstructure Hyper eutectic cast iron consists of cementite and pearlite. At room temperature microstructure Hypereutectic C.I consists of dendrites of primary cementite in the matrix of transformed Ledeburite.

Specimen	White cast iron
Composition	2.3 to 3% carbon, 0.5% silicon, 0.4% manganese, 0.05% sulphur, 0.3% phosphorous
Specimen	Grey cast iron
Composition	3.5% carbon, 2% silicon, 0.5% manganese, 0.4% phosphorous, 0.09% Sulphur
Specimen	Grey cast iron
Composition	3.5% carbon, 2% silicon, 0.5% manganese, 0.4% phosphorous, 0.09% Sulphur
Heat treatment	Nil
Etchant	Nital
Etching time	20 seconds

PROCEDURE: -

- **Selection of the Specimen:** It is essential that the specimen would be selected from the metal which can be representative of the whole mass
- **Cutting of the Specimen:** The cutting of the selected metal is made with the help of a Saw of trepanning tool and an abrasive wheel for fine sizing
- **Belt grinding:** One of the faces of the specimen is pressed against the emery belt of the belt grinder so that all scratches on the specimen surface are unidirectional.
- **Intermediate polishing:** The sample is to be polished on 220, 320, 400, 600, 800, 1/0, 2/0, 3/0, and 4/0 emery papers with increasing fineness of the paper. While changing the polish paper, the sample is to be turned by 90° so that new scratches shall be exactly perpendicular to previous scratches.
- **Disc polishing (Fine polishing):** After polishing on 4/0 paper the specimen is to be polished on disc polishing machine. In the disc-polishing machine a disc is rotated by a vertical shaft. The disc is covered by a velvet cloth. Alumina solution is used as a abrasive. Alumina solution is sprinkled continuously over the disc and specimen is gently pressed against it. In case of Non-Ferrous metal such as Brass, Brasso is used instead of Alumina and water. The polishing should be continued till a mirror polished surface is obtained.
- The sample is then washed with water and dried.
- **Etching:** The sample is then etched with a suitable etching reagent. After etching the specimen should be washed in running water and then with alcohol and finally dried.
- The sample is now ready for studying its microstructure under the microscope.

Precautions: -

- Grinding should be done on the emery papers only in one direction.
- While polishing the specimen uniform pressure should be exerted on the specimen.
- While going to the next grade of emery papers, the specimen has to be rotated through 90°.
- While switching over to new emery paper, specimen should be thoroughly washed with water to remove all loose particles.
- After etching the specimen should be washed away within a few seconds.
- Operate the Microscope Knobs gently (without jerks)

RESULT & CONCLUSIONS: - Thus the microstructure of the given specimen has been studied.

VIVA QUESTIONS

1. What are the different types of cast irons?
2. What is the difference between white cast iron and Grey cast iron?
3. What are the important properties of Grey cast iron?
4. Why white cast iron has limited applications?
5. What is the structure of Malleable cast irons?
6. Explain the heat treatment cycles used for black heart and white heart malleable iron?
7. What is the additional metal added for spheroidisation for Hypo and Hyper eutectic cast irons? How do they act?
8. What is chilled cast iron?
9. What is the difference between Ferrite malleable, pearlitic malleable and Pearlitic Ferritic malleable cast irons?
10. Why has Gray cast iron got that name?

EXPERIMENT – 05

MICRO STRUCTURE OF ALUMINIUM, BRASS AND BRONZE

AIM: -To prepare and study the Micro Structure of Aluminium, Brass and Bronze.

APPARATUS / EQUIPMENT: -

- Abrasive Cut-Off Wheel Machine.
- Specimen Mounting Press.
- Belt Grinding Machine.
- Double disc Polishing Machine.
- Metallurgical Microscope.

Consumables/ Raw material:

Rod or Sample pieces of Aluminium, set of emery papers (220, 320, 400, 600, 1/0, 2/0, 3/0, and 4/0) Bakelite powder, lapping cloth, Alumina powder of different grades.

Etchant: Keller's reagent (190 ml distilled water, 5 ml Nitric acid, 5 ml Hydrochloric acid, 2 ml Hydrofluoric acid)

THEORY: -

The best known characteristic of aluminium is its light weight; Aluminium has good malleability and formability, high corrosion resistance and high electrical and thermal conductivity. Pure aluminium has a tensile strength of about 13,000psi. One of the important characteristic of aluminium is its machinability and workability.

Brasses are alloys of copper; contain zinc as a principal alloying element. The equilibrium solubility of Zn in Cu is around 38% and is sharply influenced by cooling rate. Under the conditions of usual cooling rates encountered in industrial practice, the solubility limit may go down to 30%. With Zn additions exceeding the solubility limit, a second phase β is formed. Beta intermediate phase exhibits order-disorder transformation between 453⁰C and 470⁰C. Below this temperature, the structure of β is ordered and above this is disordered. With more than 50 % Zn another phase γ (intermediate phase) is formed.

Bronzes are the alloys of copper containing elements other than zinc. In these alloys, zinc may be present in small amount. Originally the name bronze was used to denote copper-tin alloys.

Commercially important bronzes are aluminium bronzes, phosphor bronzes, tin bronzes, beryllium bronzes and silicon bronzes. Phosphor bronzes, or tin bronzes, are alloys containing copper, tin and phosphorous. The phosphor bronzes contain 0.5 and 11% tin and 0.01 to 0.35% phosphorous

PROCEDURE: -

- **Selection of the Specimen:** It is essential that the specimen would be selected from the metal which can be representative of the whole mass
- **Cutting of the Specimen:** The cutting of the selected metal is made with the help of a Saw of trepanning tool and an abrasive wheel for fine sizing
- **Belt grinding:** One of the faces of the specimen is pressed against the emery belt of the belt grinder so that all scratches on the specimen surface are unidirectional.
- **Intermediate polishing:** The sample is to be polished on 220, 320, 400, 600, 800, 1/0, 2/0, 3/0, and 4/0 emery papers with increasing fineness of the paper. While changing the polish paper, the sample is to be turned by 90^0 so that new scratches shall be exactly perpendicular to previous scratches.
- **Disc polishing (Fine polishing):** After polishing on 4/0 paper the specimen is to be polished on disc polishing machine. In the disc-polishing machine a disc is rotated by a vertical shaft. The disc is covered by a velvet cloth. Alumina solution is used as an abrasive. Alumina solution is sprinkled continuously over the disc and specimen is gently pressed against it. The polishing should be continued till a mirror polished surface is obtained.

The sample is then washed with water and dried.

- **Etching:** The sample is then etched with a suitable etching reagent. After etching the specimen should be washed in running water and then with alcohol and finally dried.

The sample is now ready for studying its microstructure under the microscope

Precautions: -

- Grinding should be done on the emery papers only in one direction.
- While polishing the specimen uniform pressure should be exerted on the specimen.
- While going to the next grade of emery papers, the specimen has to be rotated through 90°.
- While switching over to new emery paper, specimen should be thoroughly washed with water to remove all loose particles.
- After etching the specimen should be washed away with in a few seconds.

RESULT & CONCLUSIONS: - Thus the microstructure of the given specimen has been studied.

VIVA QUESTIONS

1. What are the differences between Brass and Bronze?
2. Brass is an alloy of what?
3. What is the appearance of copper?
4. What is the melting point of Copper?
5. Which bronze alloy is commonly used as bearing alloy?
6. How much tin is contained in a Babbitt metal?
7. Babbitt metals are also known as?
8. What is the melting point of magnesium?
9. What is the melting point of titanium?
10. Which nickel alloy is used as a substitute in tableware and jewellery?

EXPERIMENT – 06

JOMINY QUENCH TEST

AIM: - To study hardness as a function of quench rate and investigate the hardenability of steels.

EQUIPMENT AND MATERIAL REQUIRED: -

1. Furnace that attains required hardening temperature.
2. Jominy end quench apparatus.
3. Brinell's hardness testing machine.
4. Proper tongs and hand gloves.
5. Specimen.

Specimen of Furnace Used: -

Power- 2KW, Voltage-250V

Max temperature- 850° C

Hardness of a material is defined as the ability of a material to resist plastic deformation. Whereas ***Hardenability*** of materials is its ability to get hardened as a result of hardening heat treatment.

A steel that has highest hardenability is one that has martensite, not only at the surface but throughout the entire interior or core of the steel.

The Hardenability of steels depends on

- a. Composition of the steel and method of manufacture
- b. Quenching medium and the method of quenching
- c. Section (thickness) of steel

THEORY: - The test consists of heating a standard steel specimen to a given quenching temperature for a specific period of time followed by a water, quenching at one end under specified conditions. The specimen must be a BS4437 (or) IS: 3848-1966. The quenched specimen is subjected to hardness test of various parts from the quenched end along the length of the piece from the quenched end.

Specimen standards: - BS 3337 (or) IS 3848 - 1966

Process parameters: -

- Water inlet orifice diameter 12.5mm
- Free jet height 62.5mm
- Distance between orifice & bottom
- End of steel bar 12.5mm
- Temp of water 21-25° C
- Quenching time 10 min

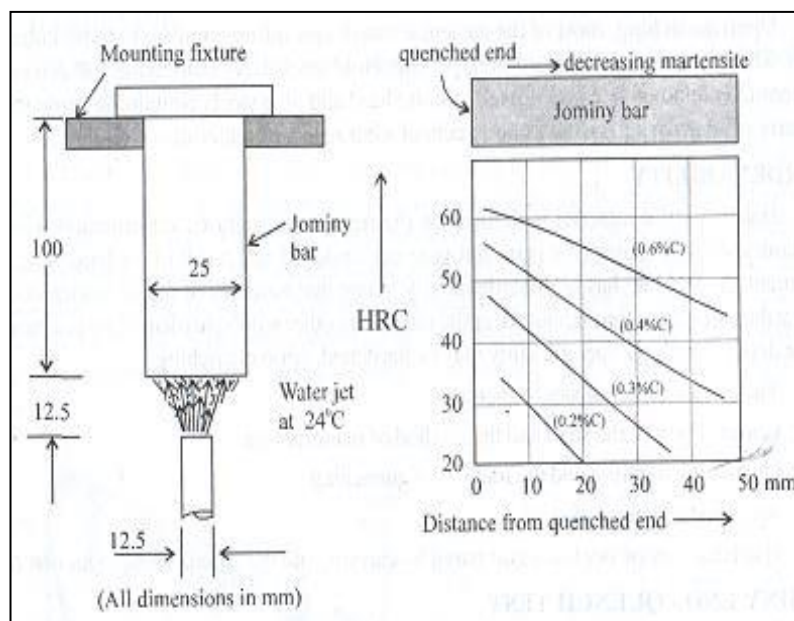

Tabular Column: -

S No.	Distance from Quenched End (mm)	BHN
1	5	
2	10	
3	15	
4	20	
5	25	
6	30	
7	35	
8	40	
9	45	
10	50	





*** Plot the graph of Distance Vs Hardness**

RESULT & CONCLUSIONS: - From Jominy test the hardening curve for specimen is obtained for different steel, kinds, and shapes of the curve varies.

VIVA QUESTIONS

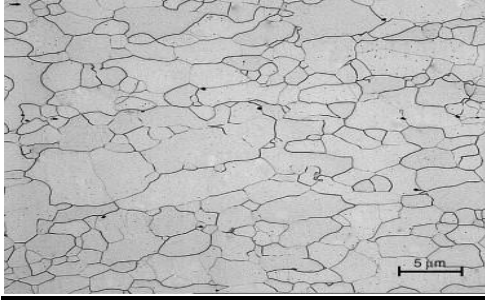
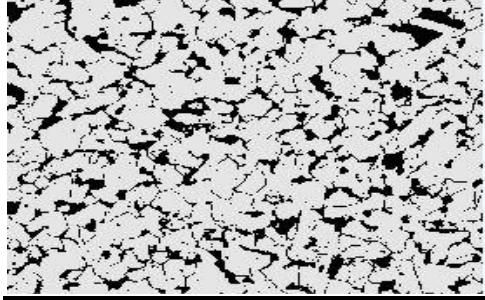
1. What is the difference between Hardness & Hardenability?
2. What is the severity of quench?
3. What is the critical diameter?
4. What is the ideal critical diameter?
5. What is the quenching medium employed in the test?
6. What are the important precautions to be observed in the test?
7. Why is a flat ground on the test specimen?
8. What is the equipment used to measure the hardness of specimens in the experiment?
9. Why does the hardness of steel increase after quench hardening?
10. What are the common heat treatment processes used in industries?

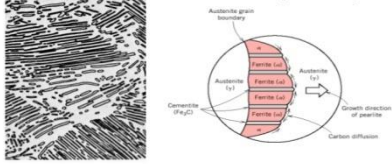
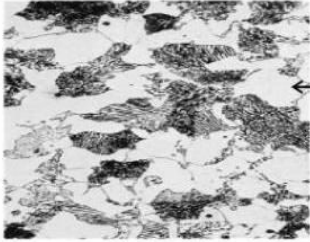
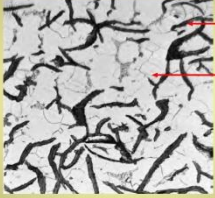
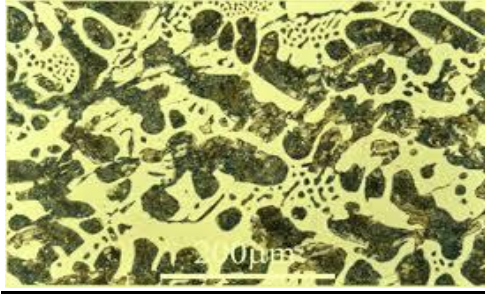
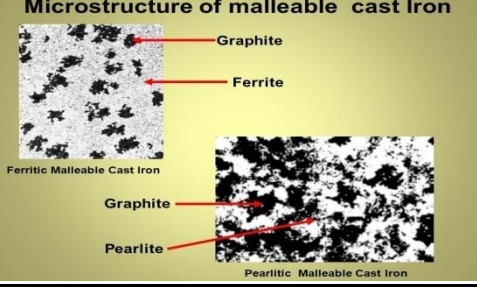
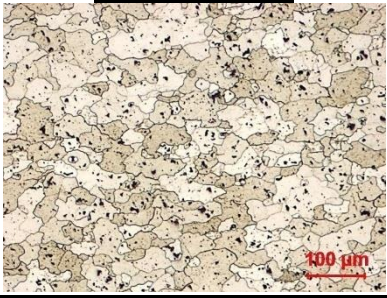
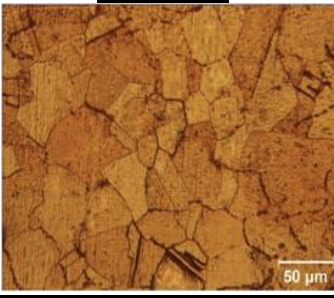
MICROSTRUCTURE IMAGES OF VARIOUS MATERIALS

<p style="text-align: center;"><u>PURE IRON</u></p> 	<p style="text-align: center;"><u>LOW CARBON STEEL</u></p> 	
<p style="text-align: center;"><u>MEDIUM CARBON STEEL</u></p>  <p style="text-align: center;">Medium-carbon AISI/SAE 1040 Steel</p>	<p style="text-align: center;"><u>EUTECTOID STEEL</u></p> <p style="text-align: center;">Microstructure of Eutectoid Steel</p> <p>In the micrograph, the dark areas are Fe₃C layers, the light phase is α-ferrite</p> <p>Pearlite nucleates at austenite grain boundaries and grows into the grain</p> 	
<p style="text-align: center;"><u>HYPO ETECTOID STEEL</u></p>  <p style="text-align: center;">Microstructure of Hypoeutectoid Steel</p>	<p style="text-align: center;"><u>GREY CAST IRON</u></p> <p style="text-align: center;">Microstructure of gray cast iron</p>  <p style="text-align: center;">Ferritic gray iron</p>	
<p style="text-align: center;"><u>WHITE CAST IRON</u></p> 	<p style="text-align: center;"><u>MALLEABLE CAST IRON</u></p> <p style="text-align: center;">Microstructure of malleable cast iron</p>  <p style="text-align: center;">Ferritic Malleable Cast Iron</p> <p style="text-align: center;">Pearlitic Malleable Cast Iron</p>	
<p style="text-align: center;"><u>ALUMINIUM</u></p> 	<p style="text-align: center;"><u>COPPER</u></p> 	<p style="text-align: center;"><u>BRASS</u></p> 

PART-B

MATERIALS TESTING LAB

EXPERIMENT-07

TENSION TEST ON UTM

AIM: -

To find the Modulus of elasticity of the given material of the specimen and also

Find:

- Yield stress
- Ultimate stress
- Breaking stress
- Percentage of elongation
- Percentage reduction in cross-sectional area of the specimen

APPARATUS: -

Universal Testing Machine, Vernier caliper, Steel rule and Specimen.

THEORY: -

In this test the ductile extension of the material is studied at different loads. The specimen (ductile material) is fixed in between the grips of the machine and a gradually increasing pull is applied along its length. The loads are measured on the main dial of the machine and the extensions on the elongation scale. The stress-strain diagram is plotted to study the behaviour of the material at different loads.

The stress-strain diagram for a mild steel specimen is shown in figure. The diagram begins with a straight line O to A, in which stress is directly proportional to strain. Point A marks the limit of proportionality beyond which the curve becomes slightly curved, until point B, the elastic limit of the material. If the load is increased further, yielding takes place; Point C is the point of sudden large extension, known as yield point. After the yield point stress is reached, the ductile extensions take place, the strains increasing at an accelerating rate as represented by C and D. The material becomes perfectly plastic in this region (C to D), which means that it can deform without an increase in the applied load. If the load is further increased, the steel begins to strain harden. During strain hardening, the material appears to regain some of its strength and offers more resistance, thus requiring increased tensile load for further deformation. The point E is the maximum load or ultimate load up to which the bar extends uniformly over its parallel length, but if straining is continued, a local deformation (neck formation) starts at E and after considerable local extension, the specimen breaks at F called breaking stress.

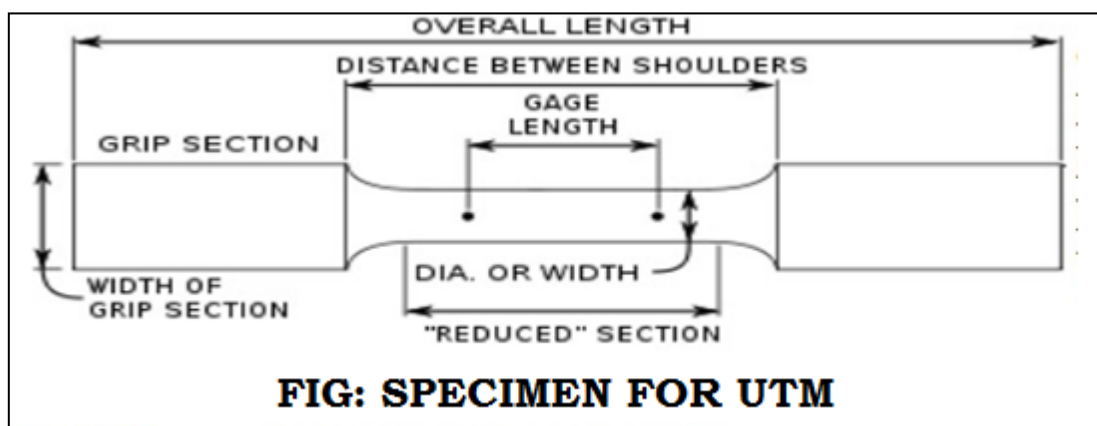
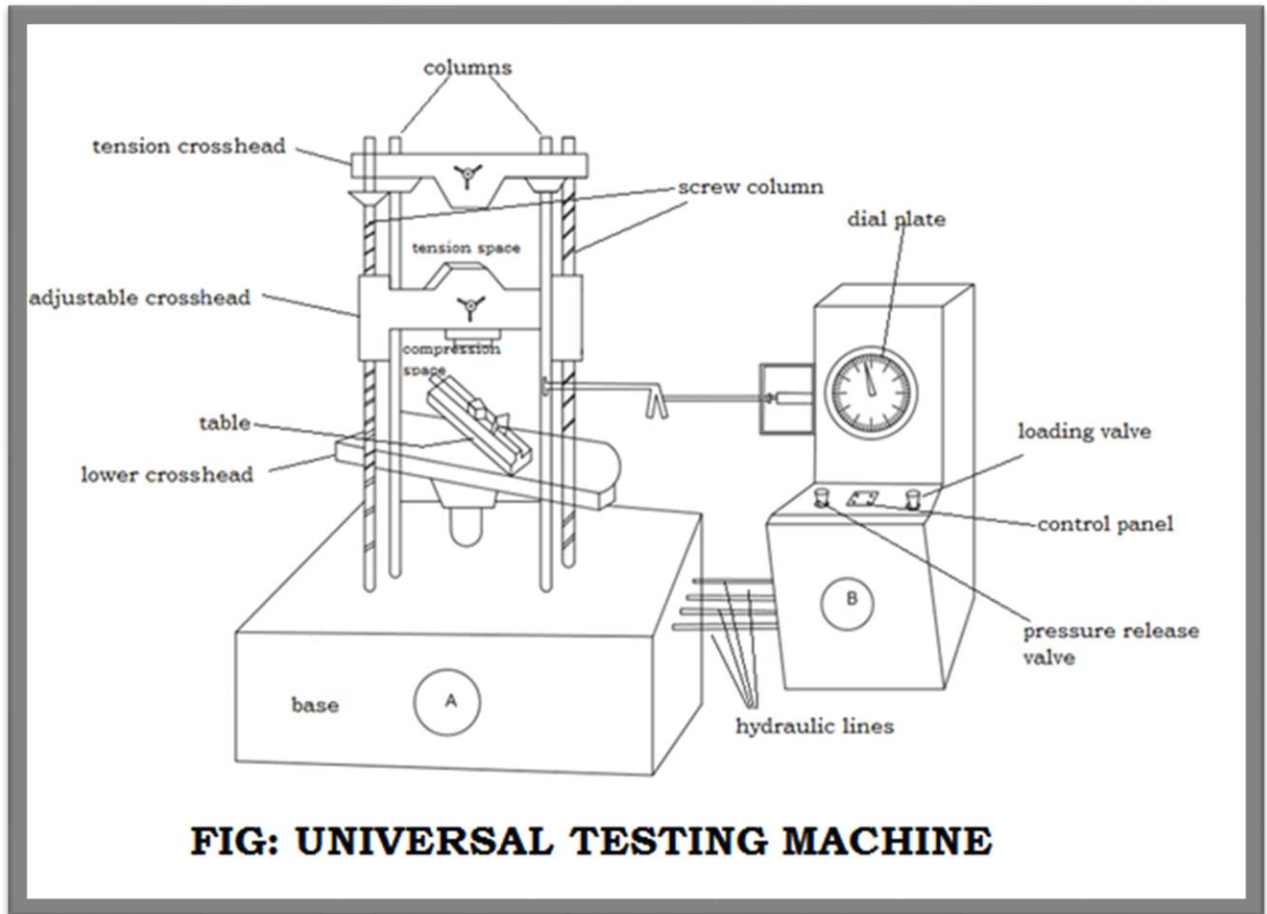

PROCEDURE: -

1. Measure the diameter of the given mild steel rod by Vernier caliper.
2. Mark the gauge length on the rod with steel rule.
3. Fix the specimen securely in the jaws of the machine, i.e., between center and upper cross heads.
4. Switch on the power knob and hydraulic button.
5. Keep the left control valve fully in closed position and now slightly open the right control valve and close it after the lower table is slightly lifted up i.e., when the pointer on the dial starts moving.
6. Turn the right control valve slowly to open position (anti clockwise) until desired loading rate is achieved.
7. Now the specimen is under gradually increasing axial load.
8. Note down the loads and corresponding extensions of the specimen.
9. The load shown by red pointer when the black pointer starts falling down indicates the ultimate load.
10. Note down the breaking load on hearing the breaking sound of the specimen after the load starts falling from ultimate load.
11. Now close the right control valve and open the left control valve (return valve) which allows the oil from the cylinder to go back to the tank so that the working piston comes down.
12. Remove the broken pieces and plot the GRAPH taking stress on Y- axis and corresponding strain on X- axis to find the young's modulus, Yield stress, Ultimate stress, breaking stress etc.

Observations: -

1. Initial (or) original diameter of the specimen, $d_0 =$ mm.
2. Initial (or) original gauge length of the specimen, $l_0 =$ mm.
3. Final (or) neck diameter of the specimen, $d_f =$ mm.
4. Final length of the broken specimen, keeping the broken pieces together $l_f =$ mm.

Tabular Column: -

S. No	Load 'P' (kN)	Elongation 'δl' (mm)	Stress 'σ' = P/A_0	Strain 'ε' = $\delta l/l_0$

Formulas: -

1) The original area of cross-section of the specimen,
 $A_0 = \pi d_0^2/4 = \quad \text{mm}^2.$

2) Stress $\sigma = \text{Load/ Area of cross-section}$
 $= P/A_0 \quad \text{N/mm}^2$

3) Strain $\epsilon = \text{elongation /Original length}$
 $= \delta l/l_0.$

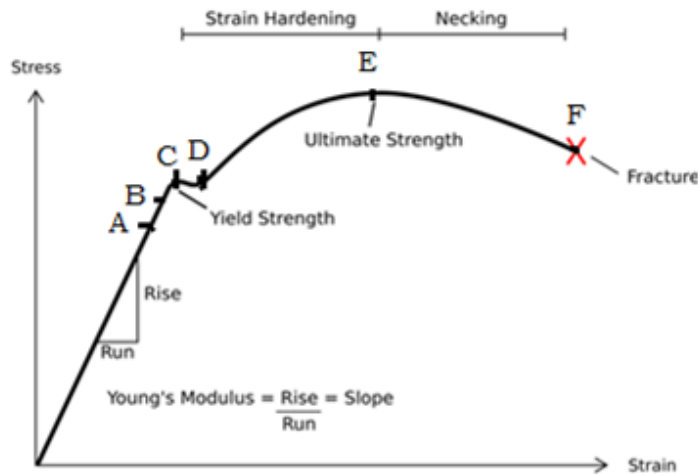

GRAPH: STRESS vs STRAIN FOR DUCTILE MATERIAL

Plot a graph taking stress on Y-axis and corresponding strain on X-axis. Within the proportional limit (i.e., within straight line portion)

Young's modulus = Slope of the straight line portion

i.e., $E = \text{Stress/Strain}$

$E = \sigma / \epsilon \quad \text{N/mm}^2.$

From the GRAPH calculate the following the values.

$$\begin{aligned} \text{(i) Yield strength} &= \frac{\text{Load at yield point}}{\text{area of cross section}} = \frac{N}{\text{mm}^2} \\ &= P_y / A_0 \end{aligned}$$

$$\begin{aligned} \text{(ii) Ultimate strength} &= \frac{\text{maximum tensile load}}{\text{area of cross-section}} = \frac{N}{\text{mm}^2} \\ &= P_u / A_0 \end{aligned}$$

$$\begin{aligned} \text{(iii) Breaking stress} &= \frac{\text{Breaking load}}{\text{Area of cross-section}} = \frac{N}{\text{mm}^2} \\ &= P_b / A_0 \end{aligned}$$

$$\begin{aligned} \text{(iv) Percentage of elongation} &= \frac{\text{final length} - \text{original length}}{\text{original length}} = \% \\ &= \frac{(l_f - l_o)}{l_o} \times 100. \end{aligned}$$

$$\begin{aligned} \text{(v) Percentage of reduction in cross-sectional area} &= \\ &= \frac{\text{original area} - \text{area of fracture}}{\text{original area}} = \% \end{aligned}$$

$$= \frac{(A_o - A_f)}{A_o} \times 100.$$

Precautions: -

1. The loads due to weights (dead weights) of cross-heads must be removed.
2. The gripping of specimen in the jaws must be perfect.
3. Operate the control valves slowly.
4. After completion of the test release the hydraulic load by opening the left control valve.

Space for Calculations: -

RESULTS & CONCLUSIONS: -

1. The Young's modulus of the material, E = N/mm²
2. The Yield stress of the specimen = N/mm²
3. The Ultimate stress = N/mm²
4. The Breaking stress = N/mm²
5. The percentage of elongation = %
6. The percentage reduction in cross-section = %

VIVA QUESTIONS

1. Loading accuracy of the UTM machine is?
2. Which type of motor used in the UTM?
3. Define stress?
4. Define strain?
5. What is the unit of stress?
6. What is the unit of strain?
7. Why we are using only rectangular threading in the UTM is
8. Define young's modulus of elasticity?
9. What is the unit for young's modulus of elasticity?
10. What is the purpose of UTM?
11. Define tensile stress?
12. Define Compressive stress?
13. What is elastic limit?
14. What is the relation between E, K & C?
15. What is linear strain?
16. Define unit stress?
17. Define volumetric strain
18. Define modulus of elasticity?
19. What is the relation between the modulus of elasticity (E) and modulus of Rigidity (G)?

EXPERIMENT-08

IMPACT TEST

AIM: -

To determine the impact strength of specimen by Izod & Charpy impact test

APPARATUS: -

1. Impact testing machine
2. A steel specimen 75 mm x 10mm x 10mm
3. Vernier caliper

M/C Specifications: -

Capacity: Energy range:

i. Charpy: 0-300 J.

ii. Izod: 0-168 J.

Model: ITM-300

THEORY: -

An impact test signifies toughness of material that is ability of material to absorb energy during plastic deformation. Static tension tests of un-notched specimens do not always reveal the susceptibility of a metal to brittle fracture. This important factor is determined by impact test. Toughness takes into account both the strength and ductility of the material. Several engineering materials have to withstand impact or suddenly applied loads while in service.

Impact strengths are generally lower as compared to strengths achieved under slowly applied loads. Of all types of impact tests, the notch bar tests are most extensively used. Therefore, the impact test measures the energy necessary to fracture a standard notch bar by applying an impulse load. The test measures the notch toughness of material under shock loading. Values obtained from these tests are not of much utility to design problems directly and are highly arbitrary. Still it is important to note that it provides a good way of comparing toughness of various materials or toughness of the same material under different condition. This test can also be used to assess the ductile brittle transition temperature of the material occurring due to lowering of temperature.

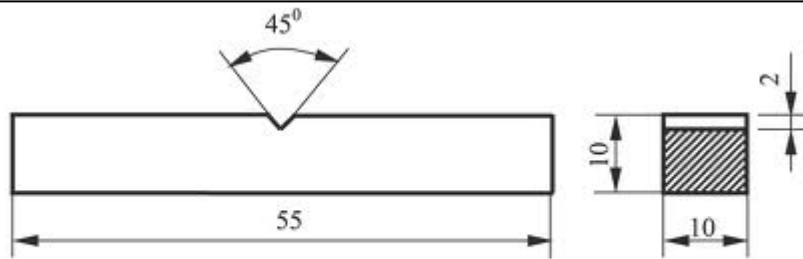

FIG: DIMENSIONS OF SPECIMEN

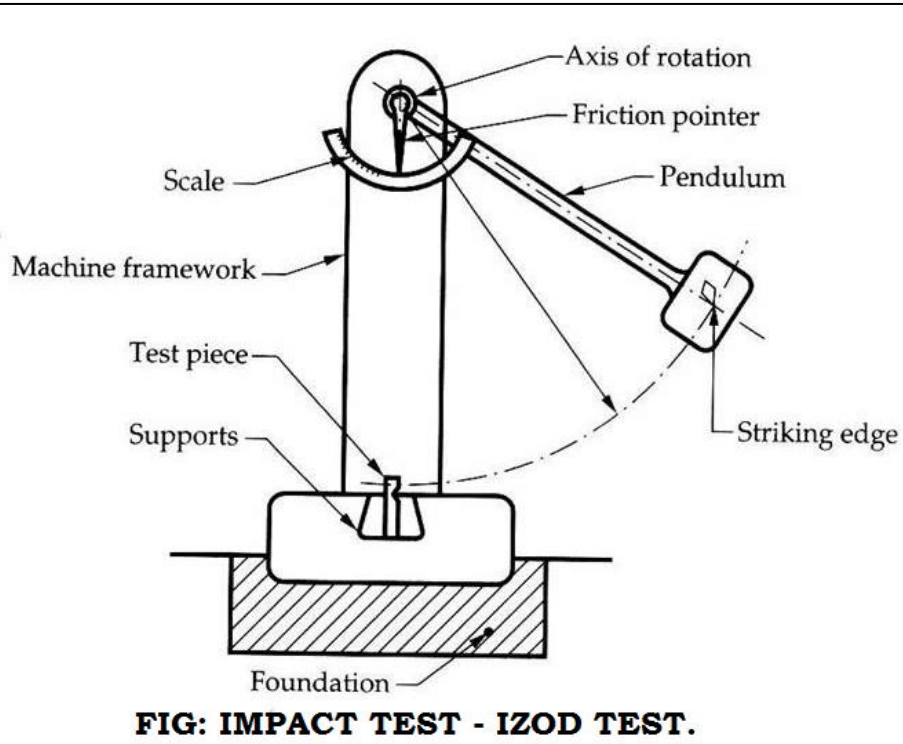

FIG: IMPACT TEST - IZOD TEST.

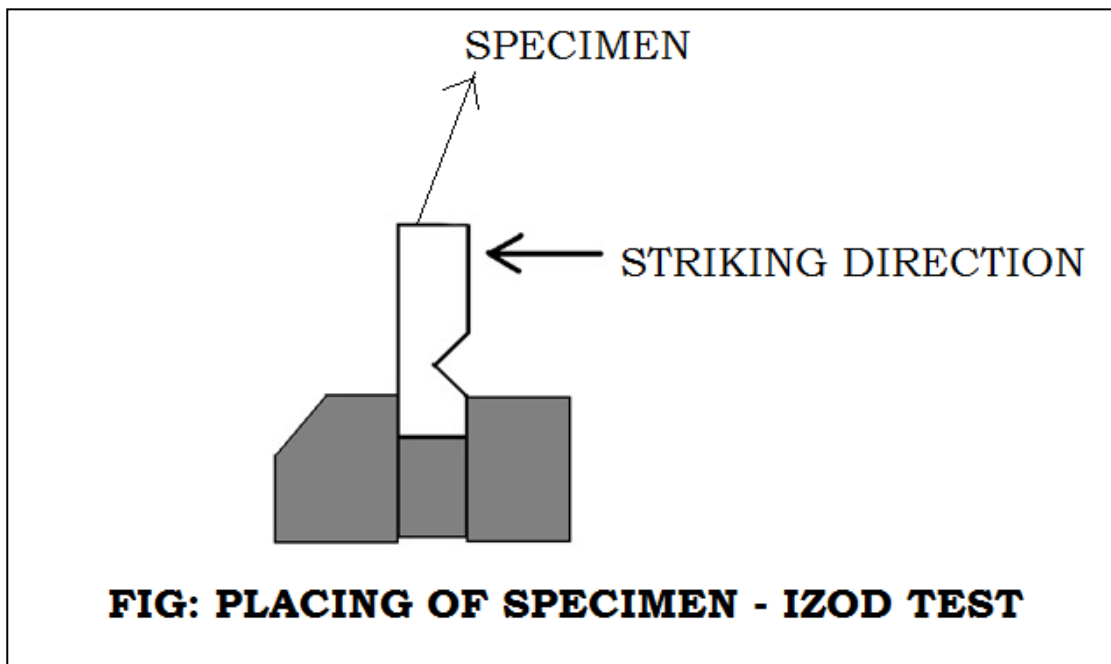

FIG: PLACING OF SPECIMEN - IZOD TEST

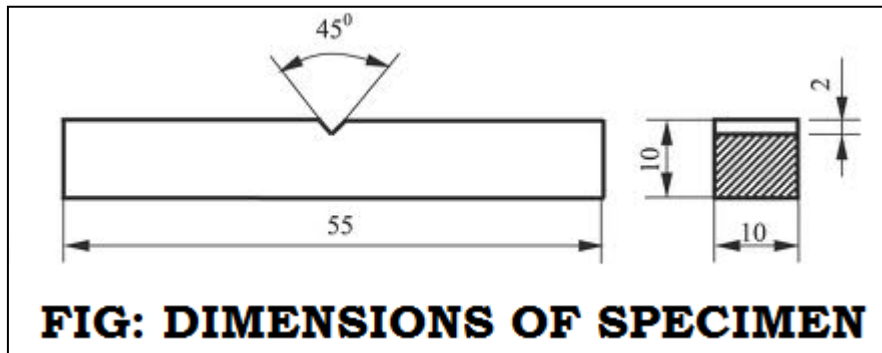

FIG: DIMENSIONS OF SPECIMEN

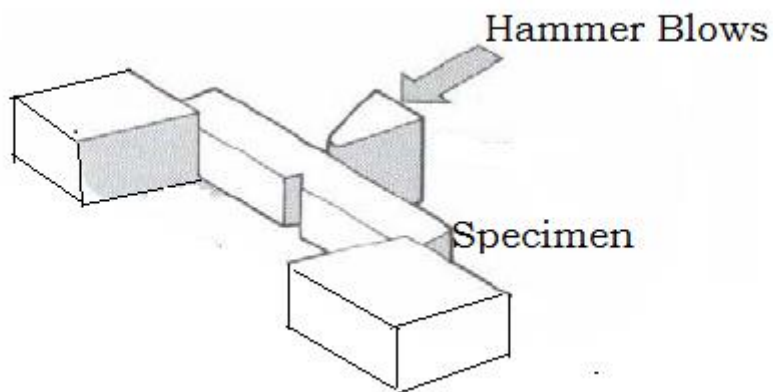

FIG: PLACING OF SPECIMEN

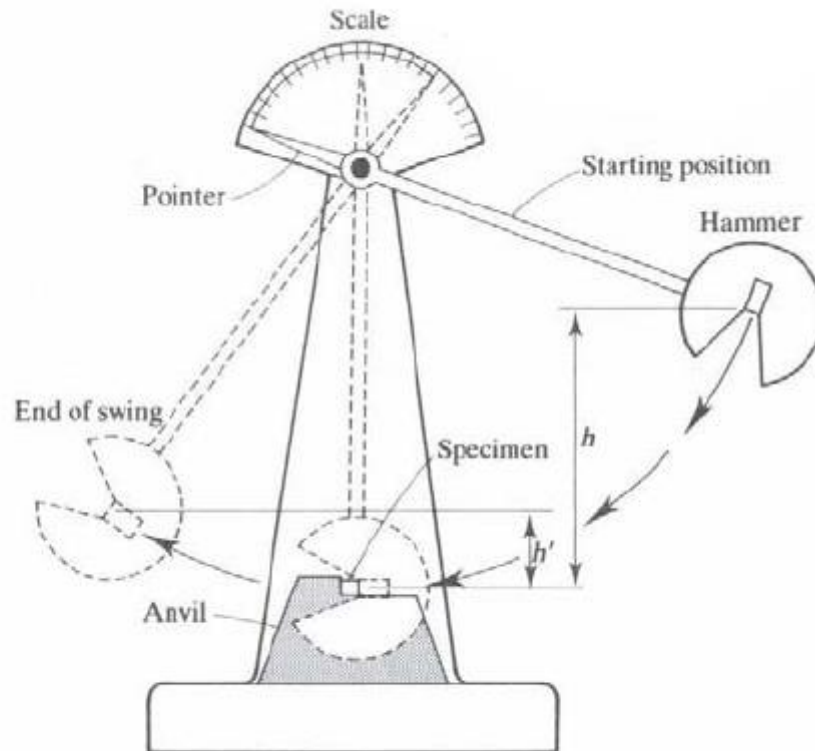

FIG: IMPACT TEST - CHARPY TEST

PROCEDURE: -

1. Measure the dimensions of specimen.
2. Rise the pendulum and keep it in position.
3. Adjust the pointer on 168 N-m reading for Izod test and 300 N-m for Charpy test on the dial which indicates the energy stored in the pendulum.
4. Clamp the specimen in the specimen support with the help of clamping screw and setting gauge. Care is to be taken that the notch on the specimen should face the pendulum striker.
5. Operate the lever so that the pendulum is released and the specimen breaks.
6. Wait till the pendulum reverses its swing and carefully retard the swinging pendulum by operating the pendulum brake.
7. Note down the impact energy.
8. Remove the broken specimen by loosening the clamping screw.

Observations & Tabular Column: -

Izod Test: -

Material of specimen	Scale reading Before fracture (U_1) Joules	Scale reading after fracture (U_2) Joules	Energy absorbed by specimen $K = (U_1 - U_2)$ Joules	Impact strength in 'J/ mm ² '

Charpy Test: -

Material of specimen	Scale reading Before fracture (U_1) Joules	Scale reading after fracture (U_2) Joules	Energy absorbed by specimen $K = (U_1 - U_2)$ Joules	Impact strength in 'J/ mm ² '

Formulas: -

The notch impact strength 'I' is calculated according to the following relation

$$I = \frac{K}{A}$$

Where,

I =impact strength	J / mm ² or N / m
K=impact energy absorbed on repute	J or N-m
A=area of cross section of specimen below the notch before test (or) Area at V-notch =B x D	mm ²
B=Breadth at V-notch	mm
D=Depth at V- notch	mm

Precautions: -

1. Measure the dimensions of the specimen carefully.
2. Hold the specimen (Izod test) firmly.
3. Note down readings carefully.

Space for Calculations: -

RESULTS & CONCLUSIONS: -

IZOD TEST: -

1. The energy absorbed for Mild Steel is found out to be (K) =-----Joules.
2. Impact strength of the specimen, (K/A) = -----J/mm²

CHARPY TEST: -

1. The energy absorbed for Mild Steel is found out to be (K)= -----Joules.
2. Impact strength of the specimen, (K/A) = -----J/mm²

VIVA QUESTIONS

1. Define load?
2. Define impact strength?
3. Define impact load?
4. Define suddenly applied load?
5. Define gradually applied load?
6. How many types of hardness machines we have?
7. Hammer holder is kept for Charpy test at what angle?
8. Hammer holder is kept for Izod test at what angle?
9. What is the purpose of hand break?
10. What is the range of dial gauge for the Izod test?
11. What is the range of dial gauge for the Charpy test?
12. Write down the formula for impact strength.
13. What is the purpose for conducting impact test?
14. What is the unit of impact energy?

EXPERIMENT: 09 **BRINELL HARDNESS TEST**

AIM: -

To find the Brinell Hardness number for the given metal specimen.

APPARATUS: -

Brinell Hardness testing m/c, Optical microscope, Indenters.

THEORY: -

'Hardness' is the property of the material by virtue of which it offers resistance to indentation (i.e., penetration), scratching or to wear. Various techniques have been developed to measure the hardness of materials using different indenter geometries and materials. Because resistance to indentation depends on the shape of the indenter and the load applied, hardness is not a fundamental property. Diameter of the indenter and the applied force depend upon the thickness of the test specimen, because for accurate results, depth of indentation should be less than 1/8th of the thickness of the test pieces. According to the thickness of the test piece increase, the diameter of the indenter and force are changed. The most common standardized hardness tests are Brinell, Rockwell, Vickers, Knoop and Scleroscope tests.

Brinelling is a term used to describe permanent indentations on a surface between contacting bodies. In this Brinell hardness test, a steel or tungsten carbide ball of specified diameter is pressed against a surface with a reasonable load. *The Brinell hardness number (BHN) is defined as the ratio of the load P, to the curved area of indentation.*

$$\text{BHN} = \frac{\text{Load applied (Kgf)}}{\text{Spherical surface area indentation (in mm)}}$$

$$\text{BHN} = \frac{2F}{\pi D (D - \sqrt{D^2 - d^2})}$$

Where P = Load in 'kg-f'

D = Diameter of the ball in 'mm'

d = Diameter of the impression (i.e. indentation) in 'mm'

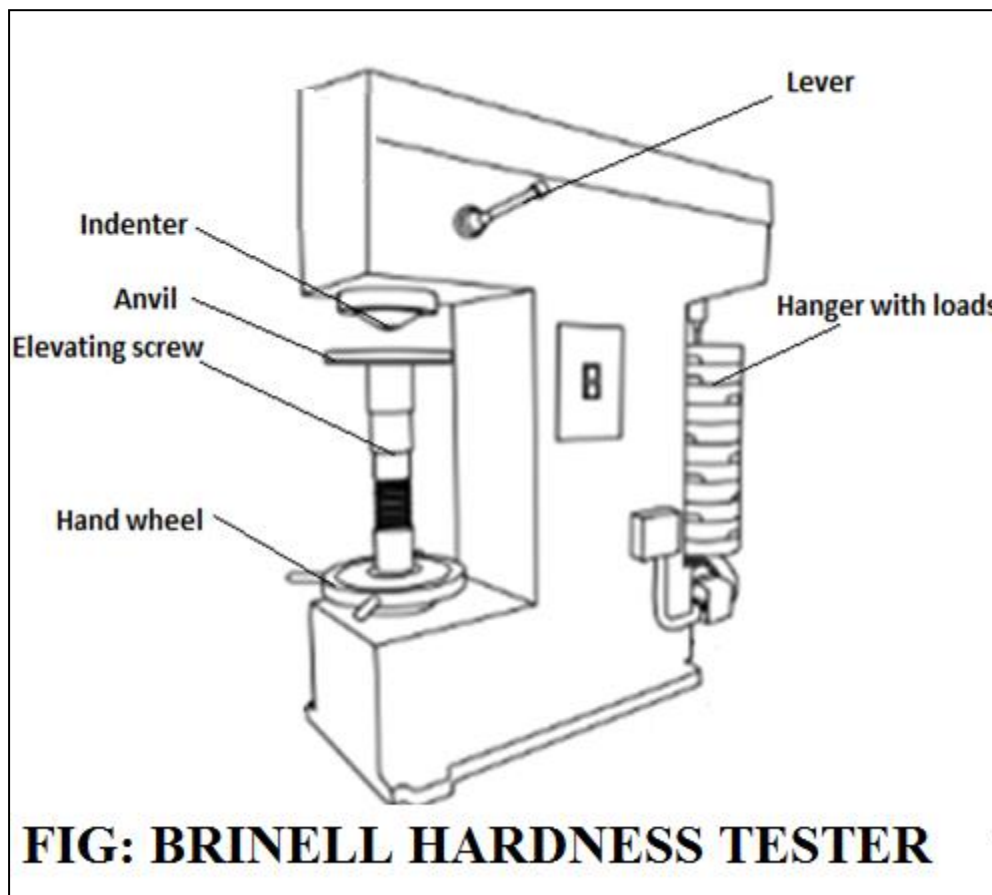
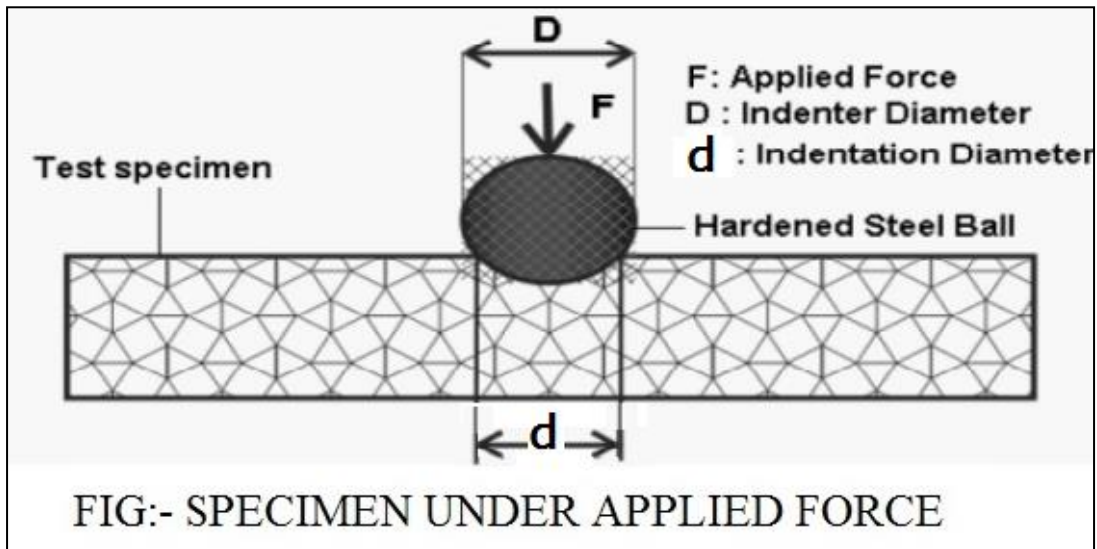

Proof: -

For any sphere of diameter “D” the surface area between any two parallel planes with distance “h” between them = $\pi D \times CE$ (as shown in fig)

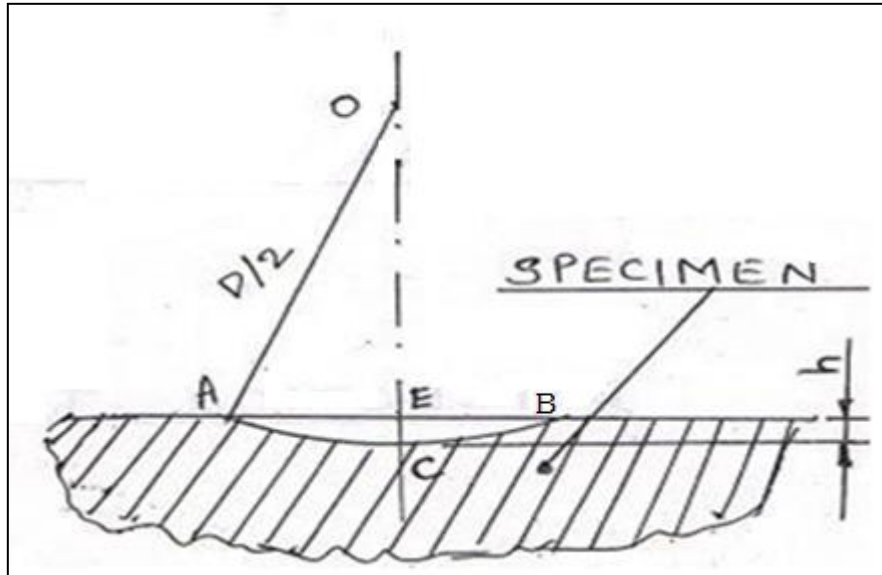

The spherical indentation in the Brinell hardness test is indicated by the portion A-C-B.

$$A = \text{Surface area of portion ACB of spheres} = \pi D \times CE$$

$$\text{But } CE = OC - OE$$

$$CE = D/2 - \sqrt{(OA)^2 - (AE)^2}$$

$$CE = D/2 - \sqrt{(D/2)^2 - (d/2)^2}$$

$$CE = D/2 - \sqrt{(D)^2/4 - (d)^2/4}$$

$$CE = \frac{1}{2} \{ D - \sqrt{(D)^2 - (d)^2} \}$$

$$\text{Surface area of portion ACB of spheres} = \pi D \times CE$$

$$A = \pi D / 2 \{ D - \sqrt{(D)^2 - (d)^2} \}$$

$$\text{Hardness} = \frac{\text{Load applied (Kgf)}}{\text{Spherical surface area indentation (in mm)}}$$

$$\begin{aligned} & \frac{F}{\pi D / 2 \{ D - \sqrt{(D)^2 - (d)^2} \}} &= & \frac{2F}{\pi D \{ D - \sqrt{(D)^2 - (d)^2} \}} \end{aligned}$$

Because the impressions made by the same indenter at different loads are not geometrically similar, the Brinell hardness number depends on the load used, and

consequently the load employed should also be cited with the test results. The Brinell test is generally suitable for materials of low to medium hardness.

The commonly used indenters with corresponding loads for typical materials are given below.

Ball diameter (D)	Load (P) 'kg-f'	Typical application
2.5 mm	$30D^2 = 187.5$	Steels and cast irons
5 mm	$10D^2 = 250$	Copper and aluminium alloys

PROCEDURE: -

1. Select the proper diameter of indenter 'D' and load for the material of the given specimen.
2. Clean the test specimen to be free from any dirt and defects or blemishes.
3. Place the specimen securely on the testing table.
4. Turn the hand wheel in clockwise direction so that the testing table moves up and the indenter will just touch the specimen.
5. Apply the load by shifting the load-lever and wait for 15 seconds. The load will be applied gradually.
6. Release the load by shifting load lever in anti-clockwise direction.
7. Turn back the hand wheel and remove the specimen.
8. Measure the diameter of the impression by optical microscope.
9. Calculate the BHN by using formula.
10. Repeat the same procedure for other material of specimen.

Tabular Column: -

S.No	Material	Load(P) (kg-f)	Diameter of indenter(D) 'mm'	Diameter of indentation (d) 'mm'			Hardness Number BHN in 'kg/mm ² '
				d1	d2	Average d = (d+ d ₂)/2	

Precautions: -

1. Before measurement, operate the load lever several times to rise and lower the weights in order to eliminate air from the hydraulic system.
2. The surface of the test piece should be clean.
3. Operate the load lever slowly for accurate results.
4. See that the surface of specimen is horizontal and is normal to axis of indenter.

Space for Calculations: -

RESULTS & CONCLUSIONS: -

The Brinell Hardness Number for the given materials is -----

VIVA QUESTIONS

1. Define hardness?
2. Define toughness?
3. Define malleability?
4. How many positions does knurling thumbscrew have?
5. What are the positions of knurling thumbscrew?
6. Which type of indenter is used for Rockwell hardness machine?
7. Which is the type of indenter used for Brinell hardness testing machine?
8. Which type of indenter is used for hard materials?
9. Write down equation for calculating hardness number using Brinell hardness test?
10. What are the different types of ferrous materials we have?
11. What are the different types of non-ferrous materials?
12. Define mechanical properties?

EXPERIMENT- 10

SHEAR FORCE AND BENDING MOMENT APPARATUS

AIM: -

To study the relationship between shear force and bending moment at 4 different sections i.e., 25cm, 20cm, 15cm and 10cm from the right support end theoretically and experimental the shear force and bending moment are calculated and tabulated.

THEORY: -

The setup consists of aluminium cross sectional beam of length 810 mm with supporting span of (75 cm – 5 cm = 70 cm). There are 2 spring balances, one vertical spring balance to read the experimental shear force and another horizontal spring balance to read the experimental bending moment. There are 4 points of applying a point load of 1kg @ 25cm, 20cm, 15cm and 10cm from the right support. The readings in different point loading are noted. Using the theoretical and experimental formula we calculate the shear force and bending moment.

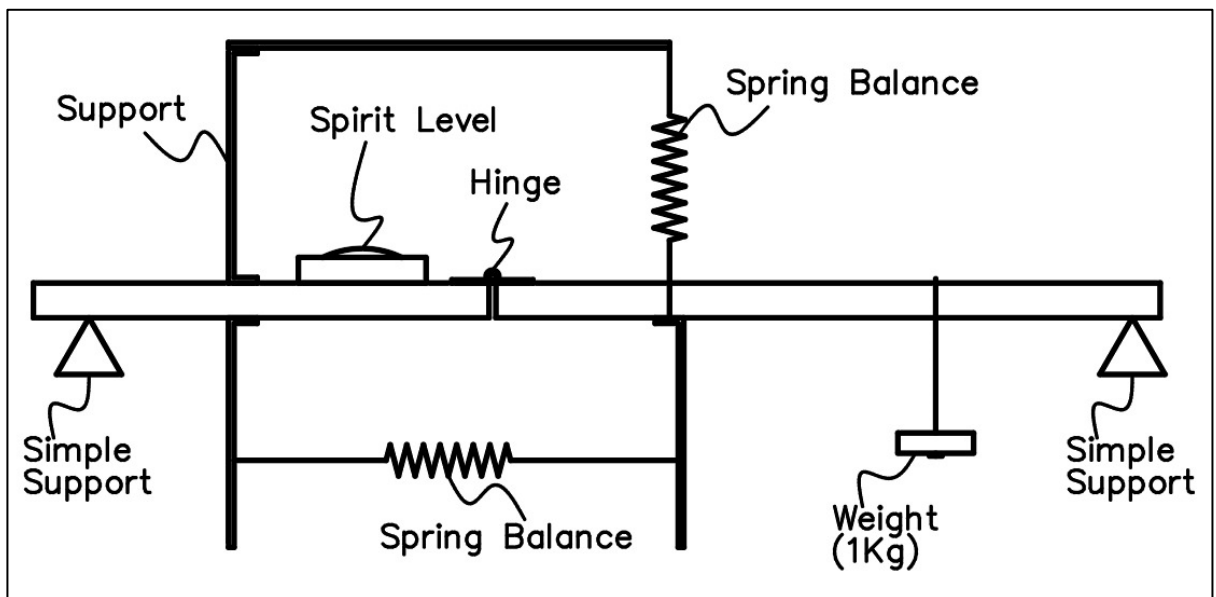

Fig: - Shear Force and Bending Moment Apparatus

Theoretical Calculations: -

$$\text{Shear Force (S.F)} = \left[\frac{W \cdot 9.81}{2} \right] \text{ Newtons.}$$

$$\text{Bending Moment (B.M)} = [\text{S.F} * x] \text{ N-m}$$

Where W is the Load applied in kg.

x = Distance of loading point from right support end.

Experimental Calculations: -

(S.F) = vertical spring Balance reading in Newton's x 0.5 instrument constant

(B.M) = Horizontal spring Balance reading in Newton's x 0.03 instrument constant.

Tabular Column: -

S.NO	LOAD APPLIED in Kgs	VERTICAL BALANCE READING (Newtons)	HORIZONTAL BALANCE READING (Newtons)	Distance (X) in meters
1.	No load with only hanger			
2.	1			
3.	1			
4.	1			
5.	1			

Space for Calculations: -

x = 0.25 m	SF (T) =
	SF (E) =
	BM (T) =
	BM (E) =
x = 0.2 m	SF (T) =
	SF (E) =
	BM (T) =
	BM (E) =
x = 0.15 m	SF (T) =
	SF (E) =
	BM (T) =
	BM (E) =
x = 0.10 m	SF (T) =
	SF (E) =
	BM (T) =
	BM (E) =

RESULTS & CONCLUSIONS: -

VIVA QUESTIONS: -

1. Define Beam.
2. What do u mean by cantilever?
3. What is simply supported beam?
4. Define overhanging beam.
5. Define continuous beam.
6. What do u mean by U.D.L?
7. Define point of contra flexure.
8. Define beam. Name its various types. Name types of loading on the beam.
9. The concavity produced on the beam section about the centre line when downward force acts on it is called as
10. The beam having one end free and one end fixed is called as
11. In bending moment diagram, if no load acts between two sections, then it is represented by
12. The graphical representation of variation of axial load on y axis and position of cross section along x axis is called as

EXPERIMENT: 11 DEFLECTION TEST- SIMPLY SUPPORTED BEAM

AIM: -

To determine the Young's Modulus (E) of given material by conducting the deflection test on simply supported beam.

APPARATUS: -

Knife – Edge Beam supports, loading yoke, slotted weights, weights hanger and dial gauge.

THEORY: -

Young's Modulus is defined as the linear stress required producing unit linear strain, within the elastic limit. Young's modulus can be found by the theory of simple bending equation.

$$\frac{M}{I} = \frac{\sigma}{y} = \frac{E}{R}$$

Where

M= Maximum Bending Moment (N-mm)

I= Moment of Inertia (mm⁴)

σ = Maximum Bending Stress (N/mm²)

y = distance from the Neutral Axis to the outermost layer (mm)

E= Young's Modulus (N/mm²)

R= Radius of Curvature (mm)

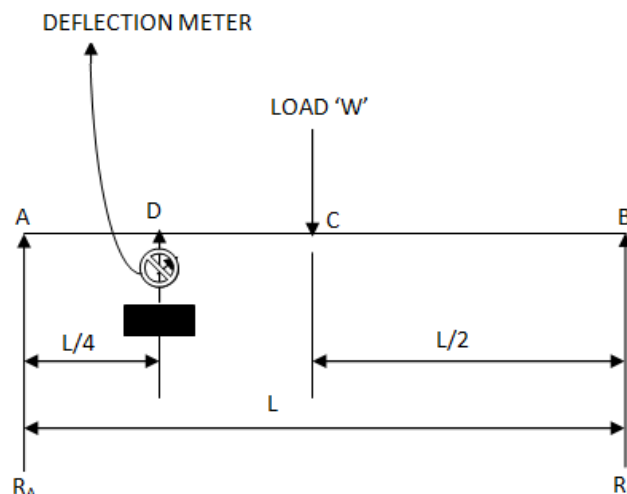

FIG: SIMPLY SUPPORTED BEAM WITH MID SPAN LOADING & QUARTER SPAN DEFLECTION

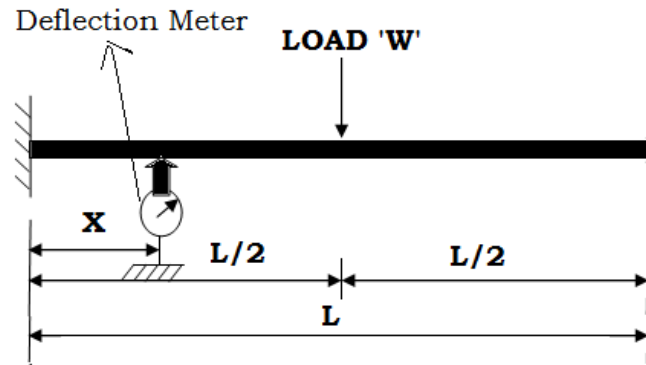

FIG: FIXED BEAM WITH LOAD AT MID-SPAN DEFLECTION AT A DISTANCE 'X' FROM LEFT END

Observations: -

Dimensions of the beam

1. Breadth of the beam = mm
2. Thickness of the beam = mm
3. Length of the beam = mm

Formulae: -

- For a *simply supported beam* with a point *load at mid-span* and *deflection* at different positions as follows.

$$\text{Mid-span deflection (y)} = \frac{W L^3}{48EI}$$

$$\text{Quarter – span deflection (y)} = \frac{11}{768} X \frac{WL^3}{EI}$$

Where,

- y = Deflection mm
- W = weight N
- L = support span length mm
- E = Young's Modulus N/mm²

$$I = \text{moment of inertia} = \frac{bd^3}{12} \text{ mm}^4 \text{ (For Rectangular C/S)}$$

- B = breadth of beam mm
- D = depth of beam mm

The generalized equation for calculating the *deflection at different positions* when *loading at mid-span* as follows.

$$EI y = \frac{Wx^3}{12} - \frac{WL^2x}{16}$$

For example if it is required to calculate deflection at mid-span

i.e., $x = L/2$

$$EI y = \frac{W(\frac{L}{2})^3}{12} - \frac{WL^2\frac{L}{2}}{16}$$

$$EI y = \frac{WL^3}{12 \times 8} - \frac{WL^3}{16 \times 2}$$

$$EI y = \frac{WL^3 - 3WL^3}{96}$$

$$EI y = \frac{-2WL^3}{96}$$

$$y = \frac{-WL^3}{48EI} \text{ ('-ve' sign indicates that deflection is in downward direction)}$$

- For a **fixed beam** with a point **load at mid-span** and deflection at a distance 'X' from left end as follows.

$$\text{Mid-span deflection (y)} = \frac{WL^3}{192EI}$$

$$\text{Deflection (y) at a distance 'X' from left end} = \frac{WX^2}{48EI}(3L-4X)$$

Where,

$$X < L/2$$

	$\delta =$ Deflection	mm
W = weight		N
L = support span length		mm
E = Young's Modulus		N/mm ²
I = moment of inertia = $\frac{bd^3}{12}$ (For Rectangular C/S)		mm ⁴
B = breadth of beam		mm
D = depth of beam		mm

PROCEDURE: -

1. Measure the dimensions (Length, Breadth and Depth) of the test beam.
2. Adjust the knife-edge supports for the required span.
3. Place the test beam over the center of supports.
4. Place the dial gauge under the beam where the deflection is to be measured.
5. Suspend the load hanger at the point where the load is to be noted.
6. Add the loads to the hanger and note the corresponding dial gauge readings for each increasing load.
7. Observe five set of readings
8. Remove the loads and note the corresponding dial gauge readings for each decreasing load.

Tabular Column: -

Simply Supported Beam: -

S. No.	Case	Load(N)	Deflection (y) mm			Deflection (y)	Young's modulus (E) N/mm ²
			Loading	Unloading	Average		

Fixed Beam: -

S. No.	Case	Load(N)	Deflection (y) mm			Deflection (y)	Young's modulus (E) N/mm ²
			Loading	Unloading	Average		

Graph: -

Draw the GRAPH for load and deflection by taking deflection on X-axis and Load on Y-axis.

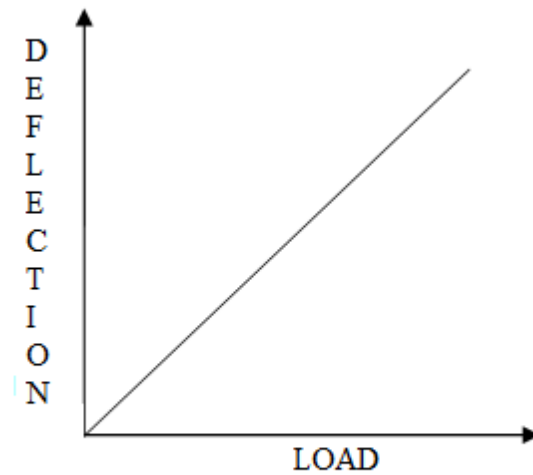

GRAPH: LOAD vs DEFLECTION

Precautions: -

1. Beam should be horizontal
2. The span of the beam should be measured properly
3. The dial gauge spindle knob should be always tightened
4. Loading hanger should be placed at center of the beam length
5. All the errors should be eliminated while taking readings.
6. Elastic limit of the beam should not exceed

Space for Calculations: -

RESULTS & CONCLUSIONS: -

Simply Supported Beam: -

Young's modulus of the given beam material (E) is = N/mm²

Fixed Beam: -

Young's modulus of the given beam material (E) is = N/mm²

VIVA QUESTIONS

1. Define beam?
2. What is meant by bending?
3. How many types of bending are there?
4. Define plane bending
5. Define oblique bending?
6. Explain the types of loads.
7. Define point load.
8. Define UDL?
9. Explain the types of beams.
10. Define Maxwell's reciprocal theorem
11. What is bending equation?
12. What are the units of bending moment?
13. What are the units of moment of Inertia?
14. What are the units for bending stress?
15. What is the Deflection of simply supported beam when a point load acts at its mid-span?
16. Define load?
17. Define cantilever beam?
18. Define over hanging beam?
19. Define simply supported beam?
20. Define fixed beam?
21. Define continuous beam?

EXPERIMENT: 12/A **COMPRESSION TEST ON SPRING**

AIM: -

To determine the stiffness and rigidity modulus of the given spring by conducting compression test.

APPARATUS: -

Open coiled helical spring, steel rule and Vernier caliper.

THEORY: -

Springs are elastic member which distort under load and regain their original shape when load is removed. They are used in railway carriages, motor cars, scooters, motorcycles, rickshaws, governors etc. According to their uses the springs perform the following Functions:

- ➔ To absorb shock or impact loading as in carriage springs.
- ➔ To store energy as in clock springs.
- ➔ To apply forces to and to control motions as in brakes and clutches.
- ➔ To measure forces as in spring balances.

To change the variations characteristic of a member as in flexible mounting of motors. The spring is usually made of either high carbon steel (0.7 to 1.0%) or medium carbon alloy steels. Phosphor bronze, brass, 18/8 stainless steel and Monel and other metal alloys are used for corrosion resistance spring. Several types of spring are available for different application. Springs may classify as helical springs, leaf springs and flat spring depending upon their shape. They are fabricated of high shear strength materials such as high carbon alloy steels spring form elements of not only mechanical system but also structural system. In several cases it is essential to idealize complex structural systems by suitable spring.

The compression test is similar to tensile test and all the mechanical properties as determined in the tensile test can be determined. When an axial compressive load 'W' is applied on a spring, every section of spring wire is subjected to a twisting moment $W \times R$, Where 'R' is the mean radius of the coil. If 'δ' is the deflection of spring due to compressive load then, the stiffness of spring,

$$\text{Stiffness, } K = \frac{W}{\delta}$$

For openly coiled spring,
$$\delta = \frac{64WR^3n}{Gd^4}$$

Tension Test: -

Outer diameter of the spring, $D_o =$ mm
 Inner diameter of the spring, $D_i =$ mm
 Diameter of the wire, $d =$ mm
 Mean radius of the spring, $R = \frac{D_o - D_i}{4} + \frac{D_i}{2} =$ mm
 No of complete turns, $n =$

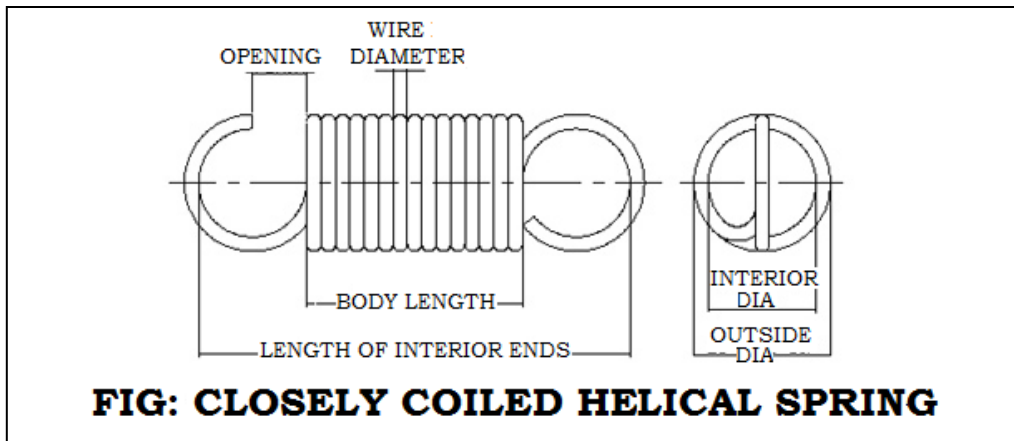

PROCEDURE: -

1. Measure the diameter of wire of the spring by means of vernier caliper.
2. Measure the spring coil diameter by means of vernier caliper.
3. Count the number of turns of the spring.
4. Insert the spring in the spring testing machine.
5. Load the spring and note the corresponding axial deflection in compression.
6. Increase the load and take the corresponding axial deflection reading.
7. Plot a curve between load and deflection.
8. The slope of the curve gives the stiffness of the spring.
9. Find the rigidity modulus of the spring material.

Tabular Column: -

Compression Test: -

S. No.	Applied Load		Deflection (δ) mm			Stiffness (k) N/mm	Rigidity modulus (G) N/mm ²
			Loading	Unloading	Average		
	Kg	N					

Tension Test: -

S. No.	Applied Load		Deflection (δ) mm			Stiffness (k) N/mm	Rigidity modulus (G) N/mm ²
	Kg	N	Loading	Unloading	Average		

Graph: -

A graph between load (W) and deflection (δ) is drawn, from the graph at a particular value of W the corresponding value of δ is noted. By using this value rigidity modulus of spring material is calculated.

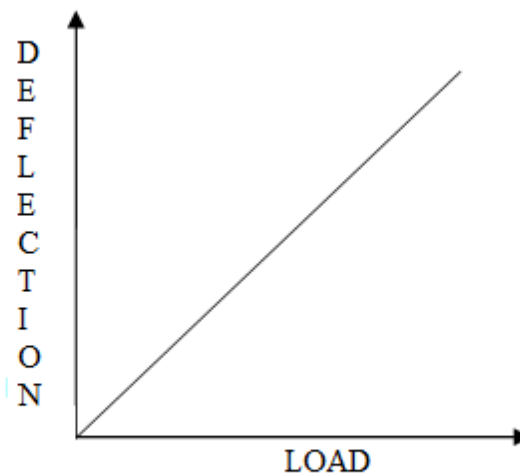

GRAPH: LOAD vs DEFLECTION

Precautions: -

1. Dimensions should be measure accurately with the help of Vernier Calipers.
2. Deflection from the scale should be noted carefully and accurately.
3. Apply the load within the elastic limit.

Space for Calculations: -

RESULTS & CONCLUSIONS: -

Compression Test: -

Stiffness of the spring, $k =$ N/mm

Modulus of rigidity, $G =$ N/mm²

From GRAPH the value of $G =$ N/mm²

Tension Test: -

Stiffness of the spring, $k =$ N/mm

Modulus of rigidity, $G =$ N/mm²

From GRAPH the value of $G =$ N/mm²

VIVA QUESTIONS

1. The load required to produce a unit deflection in the spring is called
2. In spring balances, the spring is used
3. The most important property for the spring material is
4. The springs in brakes and clutches are used
5. In a watch, the spring is used to store energy. The energy is released
6. A spring used to absorb shocks and vibrations is
7. The spring used in mechanical toys is
8. The laminated springs are given initial curvature
9. If a close-coiled helical spring is subjected to load W and the deflection produced is, then stiffness of the spring is given by
10. When a close-coiled helical spring is subjected to an axial load, it is said to be under.
11. A close –coiled helical spring is cut into two equal parts. The stiffness of the resulting springs will be
12. Two close-coiled helical springs are equal in all respects except the number of turns. If the number of turns are in the ratio of 2:3, then the stiffness of the spring will be in the ratio of

EXPERIMENT: 12/B TORSION TEST

AIM: -

To determine the Rigidity Modulus of the given specimen by conducting Torsion test.

APPARATUS: -

- A torsion testing machine along with angle of twist measuring attachment.
- Standard specimen of mild steel or cast iron.
- Steel rule.
- Vernier caliper or a micrometer.

THEORY: -

For transmitting power through a rotating shaft it is necessary to apply a turning force. The force is applied tangentially and in the plane of transverse cross section. The torque or twisting moment may be calculated by multiplying two opposite turning moments. It is said to be in pure torsion and it will exhibit the tendency of shearing off at every cross section which is perpendicular to the longitudinal axis.

Torsion Equation: -

Torsion equation is given by below

$$\frac{T}{J} = \frac{\tau}{R} = \frac{G\theta}{L}$$

Where

T = maximum twisting torque	N-mm
J = polar moment of inertia= $\pi d^4/32$ (for circular C/S)	mm ⁴
τ = shear stress	N/mm ²
G = modulus of rigidity	N/mm ²
θ = angle of twist	radians
L = length of shaft under torsion	mm

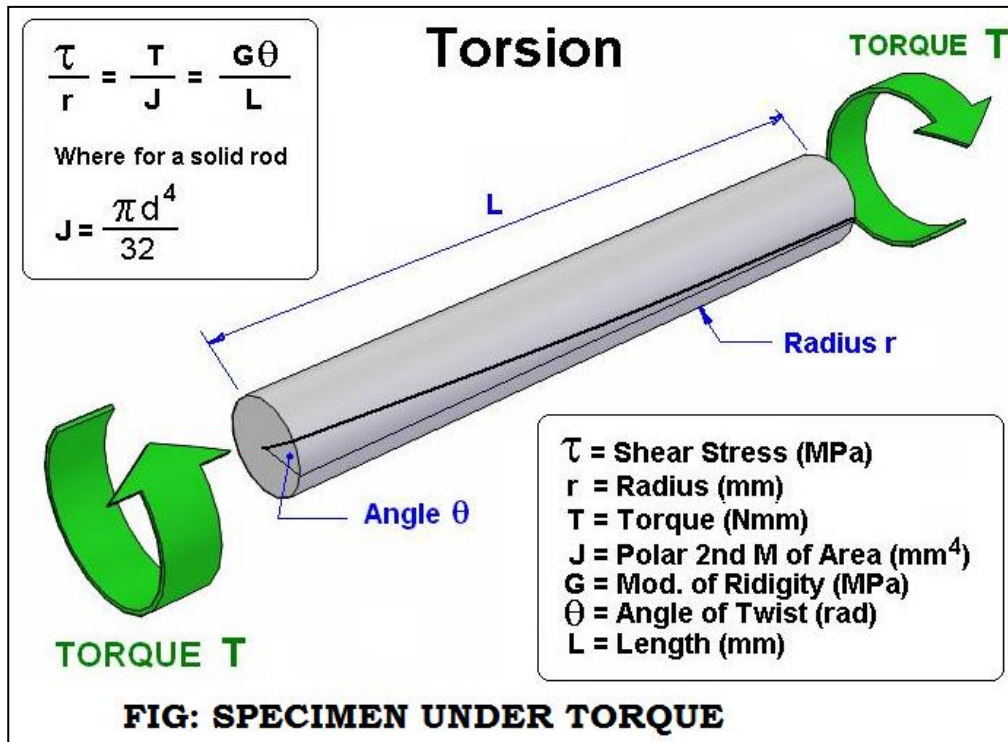

PROCEDURE: -

1. Select the driving dogs to suit the size of the specimen and clamp it in the machine by adjusting the length of the specimen by means of a sliding spindle.
2. Measure the diameter at about three places and take the average value.
3. Choose the appropriate range by capacity change lever
4. Set the maximum load pointer to zero.
5. Set the protractor to zero for convenience and clamp it by means of knurled screw.
6. Carry out straining by rotating the hand wheel in either direction.
7. Load the machine in suitable increments.
8. Then load out to failure as to cause equal increments of strain reading.
9. Plot a torque- twist (T- θ) GRAPH.
10. Read off co-ordinates of a convenient point from the straight line portion of the torque twist (T- θ) GRAPH and calculate the value of G by using relation.

Observations: -

Gauge length of the specimen, L =

Diameter of the specimen, d =

Polar moment of inertia, $J = \pi d^4/32 = \dots\dots\dots$

Tabular Column: -

Sl. No.	Torque, Angle of twist Kg-cm	Torque, N - mm	Angle of twist		Modulus Rigidity, G N/mm ²
			Degrees	Radians	

Graph: -

Torque vs. Angle of Twist

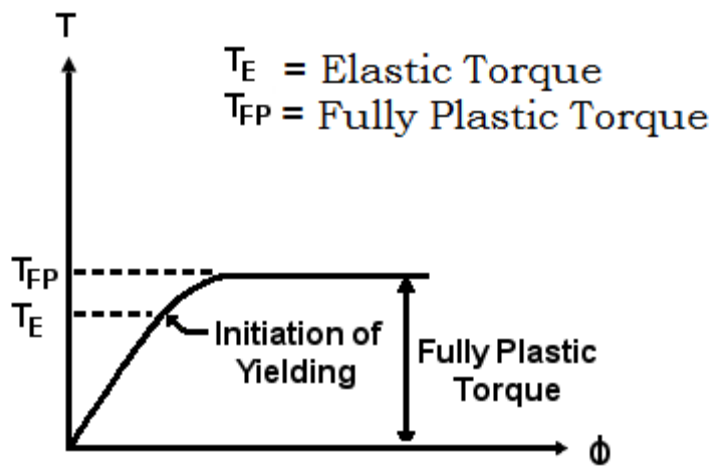

GRAPH: TORQUE vs ANGLE OF TWIST

Precautions: -

- 1) Measure the dimensions of the specimen carefully
- 2) The specimen should be properly gripped between the jaws.
- 3) Measure the Angle of twist accurately for the corresponding value of Torque.
- 4) After breaking the specimen stop the machine.

Space for Calculations: -

RESULTS & CONCLUSIONS: -

The modulus of rigidity of given material is-----N/mm²

VIVA QUESTIONS

1. Define torsion?
2. What is the formula torsion equation for circular shafts?
3. Write assumptions for torsion on shafts.
4. What are the effects of torsion?
5. Define modulus of rigidity?
6. Define angle of twist?
7. Define shaft?
8. What are the torque carrying engineering members?
9. Write formula to calculate polar moment of inertia (J)?
10. Write the formula to calculate power transmitted by the shaft?
11. Define torsional rigidity?
12. Define polar moment of inertia?
13. Define moment of inertia?

EXPERIMENT-13

ROCKWELL HARDNESS TEST

AIM: -

To find the Rockwell Hardness number for the given metal specimen

APPARATUS: -

Rockwell Hardness testing m/c, Test specimens, Indenters.

THEORY: -

'Hardness' is the property of the material by virtue of which it offers resistance to indentation (i.e., penetration), scratching or to wear. Various techniques have been developed to measure the hardness of materials using different indenter geometries and materials. Because resistance to indentation depends on the shape of the indenter and the load applied, hardness is not a fundamental property. The most common standardized hardness tests are Brinell, Rockwell, Vickers, Knoop and Scleroscope tests.

The Rockwell Hardness Number, which is read directly from a dial on the testing machine, is expressed as follows:

If the Hardness number is '55' using the 'C' scale, then it is written as '55HRC'

There are several Rockwell test scales that use different loads, indenter materials and indenter geometries. Some of the most common hardness scales and the indenters with loads are listed below.

Scale	Indenter	Load in kg-f	Dial	Application
A	Diamond	60	Black	Carbides, Thin steel, Case hardened steel
B	1/16" Ball	100	Red	Aluminium alloys, Copper alloys, Unhardened steels etc.,
C	Diamond	150	Black	Hard cast irons, Pearlitic malleable iron, Deep case hardened steel, Titanium etc.,

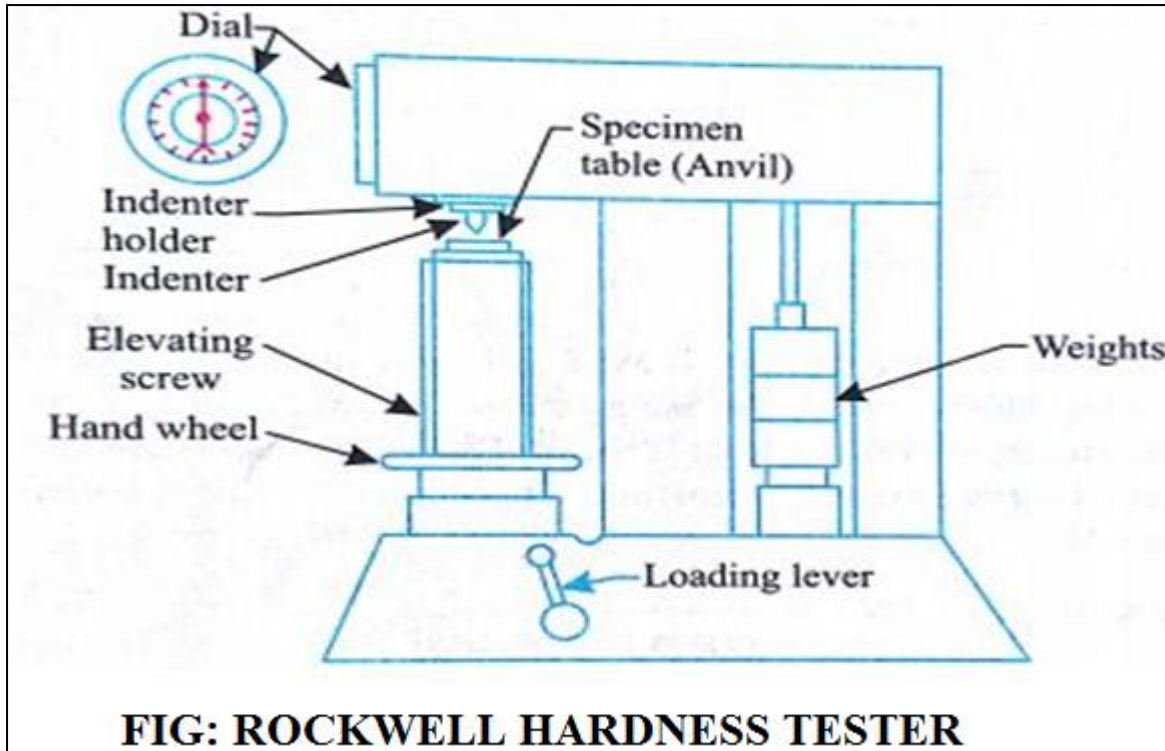

FIG: ROCKWELL HARDNESS TESTER

PROCEDURE: -

1. Select the proper diameter of indenter and load, for the material of the given specimen.
2. Place the specimen securely on the testing table.
3. Turn the hand wheel in clockwise direction so that the testing table moves up and the indenter will push into the specimen.
4. Continue the movement of hand wheel until the small pointer comes to red dot.
5. Now, turn the 'load lever' in clockwise direction slowly, so that the total load is brought into action.
6. When the long pointer of dial gauge reaches a steady position, the loads may be released by moving back the load lever in anti-clockwise direction.
7. Read the figure against the long pointer. That is the direct reading of the hardness of the specimen.
8. Turn back the hand wheel and remove the specimen.
9. Repeat the same PROCEDURE for other material of the specimens.

Tabular Column: -

S. No	Material	Rockwell scale of weights placed			TRIAL NUMBER			Rockwell Hardness Number
		Indenter	Load	Scale	T1	T2	T3	

Precautions: -

1. Select the proper indenter and load to suit the material under the test.
2. Before measurement, operate the load lever several times to rise and lower the weights in order to eliminate air from the hydraulic system.
3. Operate the load lever slowly for accurate results.
4. See that the surface of the specimen is horizontal and is normal to the axis of the indenter.
5. Don't apply the minor load beyond the Red dot.

Space for Calculations: -

RESULT & CONCLUSIONS: -

The Hardness number of the given specimen was found and its value is-----

VIVA QUESTIONS

1. Define hardness?
2. Define toughness?
3. Define malleability?
4. How many positions does knurling thumbscrew have?
5. What are the positions of knurling thumbscrew?
6. Which type of indenter is used for Rockwell hardness machine?
7. Which is the type of indenter used for Brinell hardness testing machine?
8. Which type of indenter is used for hard materials?
9. Write down equation for calculating hardness number using Brinell hardness test?
10. What are the different types of ferrous materials we have?
11. What are the different types of non-ferrous materials?
12. Define mechanical properties?

EXPERIMENT-14 **DEFLECTION TEST- CANTILEVER BEAM**

AIM: -

To determine the Young's Modulus (E) of given material by conducting the deflection test on cantilever beam.

APPARATUS: -

Cantilever Beam, loading yoke, slotted weights, weights hanger and dial gauge

THEORY: -

Young's Modulus is defined as the linear stress required producing unit linear strain, within the elastic limit. Young's modulus can be found by the theory of simple bending equation.

$$\frac{M}{I} = \frac{\sigma}{y} = \frac{E}{R}$$

Where

M= Maximum Bending Moment (N-mm)

I= Moment of Inertia (mm⁴)

σ = Maximum Bending Stress (N/mm²)

y = distance from the Neutral Axis to the outermost layer (mm)

E= Young's Modulus (N/mm²)

R= Radius of Curvature (mm)

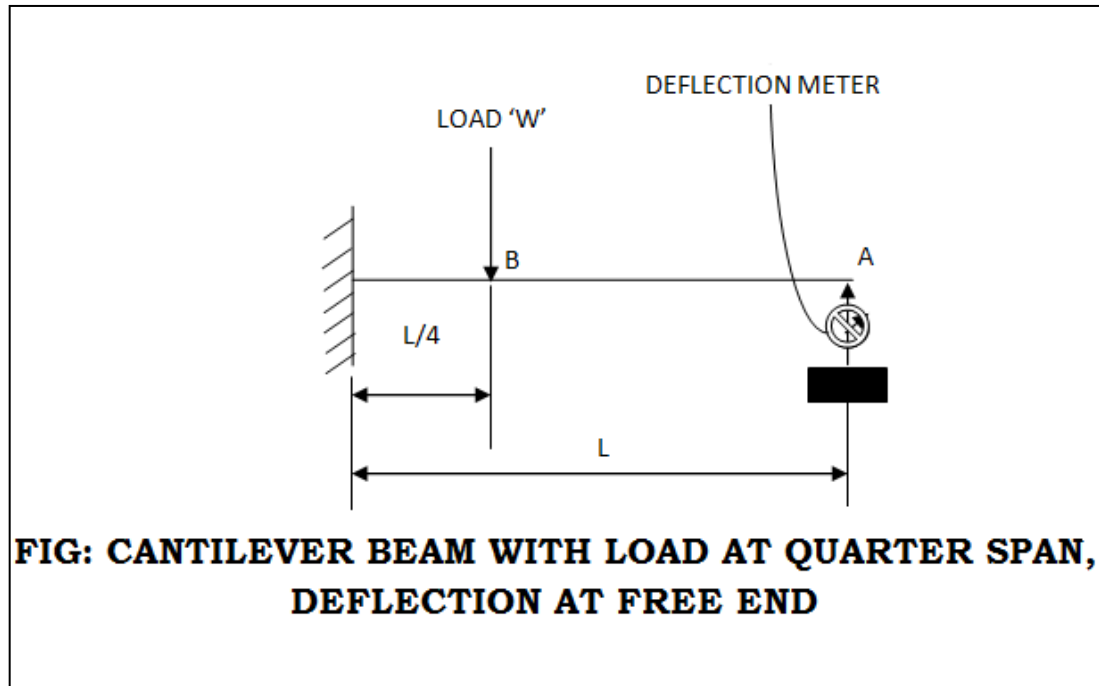

PROCEDURE: -

1. Measure the dimensions (Length, Breadth and Depth) of the test beam.
2. Place the dial gauge under the beam where the deflection is to be measured.
3. Suspend the load hanger at the point where the load is to be noted.
4. Add the loads to the hanger and note down the corresponding dial gauge readings for each increasing load.
5. Observe five set of readings
6. Remove the loads and note down the corresponding dial gauge readings for each decreasing load.

Observations: -

The generalized equation for calculating the *deflection at free end* when *loading at different positions* as follows.

$$y = \frac{Wa^2}{2EI}(L - a) + \frac{Wa^3}{3EI}$$

Where

a= Distance of the load from fixed end.

→When the point load is acting at the free end i.e., a=L,

$$\text{Then } y = \frac{WL^3}{3EI}$$

→When the point load is acting at the quarter span i.e., $a=L/4$,

$$\text{Then } y = \frac{11WL^3}{384EI}$$

Tabular Column: -

S. No.	Case	Load(N)	Deflection (δ) mm			Deflection (δ)	Young's modulus (E) N/mm ²
			Loading	Unloading	Average		

Graph: -

Draw the GRAPH between load and deflection, taking deflection on X-axis and Load on Y-axis.

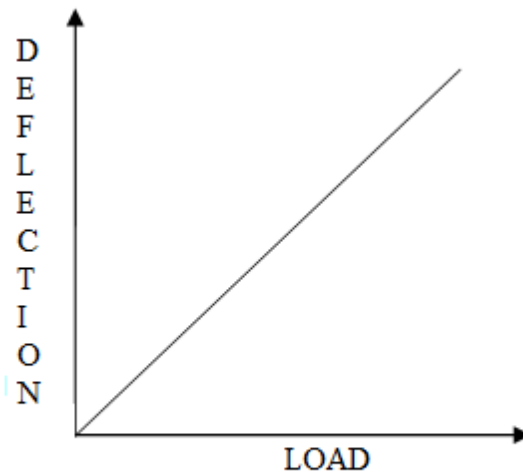

GRAPH: LOAD vs DEFLECTION

Precautions: -

1. Beam should be horizontal
2. The span of the beam should be measured properly
3. The dial gauge spindle knob should be always tightened
4. Loading hanger should be placed at center of the beam length
5. All the errors should be eliminated while taking readings.
6. Elastic limit of the beam should not exceed

Space for Calculations: -

RESULT & CONCLUSIONS: -

Young's modulus of the given beam material (E) is =

N/mm²

VIVA QUESTIONS

1. Define beam?
2. What is meant by bending?
3. How many types of bending are there?
4. Define plane bending
5. Define oblique bending?
6. Explain the types of loads.
7. Define point load.
8. Define UDL?
9. Explain the types of beams.
10. Define Maxwell's reciprocal theorem
11. What is bending equation?
12. What are the units of bending moment?
13. What are the units of moment of Inertia?
14. What are the units for bending stress?
15. What is the Deflection of simply supported beam when a point load acts at its mid-span?
16. Define load?
17. Define cantilever beam?
18. Define over hanging beam?
19. Define simply supported beam?
20. Define fixed beam?
21. Define continuous beam?

EXPERIMENT-15

FATIGUE TEST

AIM: -

To determine the fatigue limit of Aluminium by conducting fatigue test on it.

APPARATUS: -

Fatigue specimens

Micrometer or Vernier caliper

Permanent pen

Fatigue testing machine

THEORY: -

Fatigue - the process of progressive localized permanent structural change occurring in a material subjected to conditions that produce fluctuating stresses and strains at some point or points and that may culminate in cracks or complete fracture after a sufficient number of fluctuation

A method for determining the behaviour of materials under fluctuating loads. A specified mean load (which may be zero) and an alternating load are applied to a specimen and the number of cycles required to produce failure (fatigue life) is recorded. Generally, the test is repeated with identical specimens and various fluctuating loads. Loads may be applied axially, in torsion, or in flexure. Depending on amplitude of the mean and cyclic load, net stress in the specimen may be in one direction through the loading cycle, or may reverse direction. Data from fatigue testing often are presented in an S-N diagram which is a plot of the number of cycles required to cause failure in a specimen against the amplitude of the cyclical stress developed. The cyclical stress represented may be stress amplitude, maximum stress or minimum stress. Each curve in the diagram represents a constant mean stress. Most fatigue tests are conducted in flexure, rotating beam, or vibratory type machines

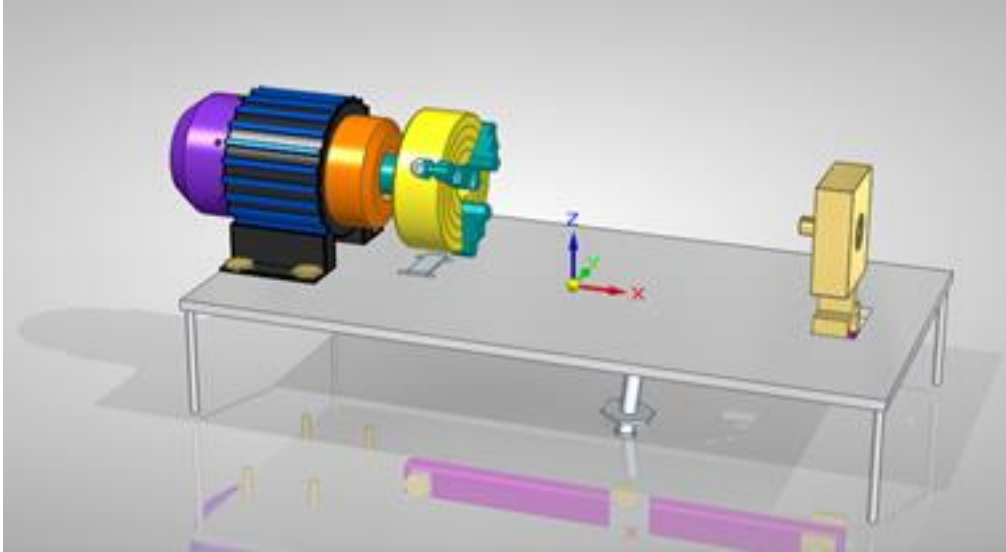

Fig: Fatigue Testing Machine

PROCEDURE: -

1. Measure dimension of aluminum specimen provided and record in table.
2. If the distance from the load end to the minimum diameter of the specimen is 185mm, the bending stress, σ can be calculated the bending stress for a load P (N) is shown in equation

$$\sigma = 125.7 * P * 32 / \pi D^3$$

3. Conduct the fatigue test at room temperature using the fatigue testing machine. Fit one end of the specimen to a motor and fit the other end to a bearing hung with a known weight, indicating the stress applied to the specimen.
4. Start the motor to rotate the specimen at a constant speed. The revolution counter is used to record the number of cycles to which the specimen fails. Record the result in table.
5. Change the weights used and follow the experiment in 2.2. Again, record the results in table.
6. Construct the S-N curves of the aluminum specimen.
7. Investigate fracture surfaces of broken fatigue specimen and sketch the result in table.
8. Analyze, discuss the obtained results. Give conclusions.

Precautions: -

The specimen should be straight in the two jaws

Care should be taken while handling the experiment

Tabular Column: -

S. NO.	SPEED	WEIGHT	TIME	NO.OF CYCLES LEAD TO FAILURE

Space for Calculations: -

RESULTS & CONCLUSIONS: -

By following above sequence of procedure we have determined the fatigue life of aluminium and the value is_____

VIVA QUESTIONS: -

1. In what terms, fatigue life is measured?
2. Fatigue curves are popularly known as _____ curves.
3. What term is used for the maximum stress at which material fail on a specified number of cycle?
4. Word “endurance limit” is used for _____
5. Which ferrous material doesn't show fatigue limit?
6. What is the reason for fatigue failure?
7. What is the relation between stress at the tension side and diameter of the fatigue test specimen?
8. Magnitude of compressive stress on the fatigue test specimen is ____ tensile stress magnitude.
9. Endurance limit has unit Kg-f.
10. Nylon has a linear S-N curve.



Estd: 2008

METHODIST

COLLEGE OF ENGINEERING & TECHNOLOGY

Approved by AICTE New Delhi | Affiliated to Osmania University, Hyderabad

Abids, Hyderabad, Telangana, 500001