



**METHODIST**  
**COLLEGE OF ENGINEERING & TECHNOLOGY**  
(An UGC-AUTONOMOUS INSTITUTION)

Estd : 2008

Accredited by NAAC with A+ and NBA  
Affiliated to Osmania University & Approved by AICTE



# LABORATORY MANUAL

## ELEMENTS OF ELECTRICAL & ELECTRONICS ENGINEERING

### LABORATORY

B.E, I Semester (Autonomous): 2021-22

NAME: \_\_\_\_\_

ROLL NO: \_\_\_\_\_

BRANCH: \_\_\_\_\_

SEM: \_\_\_\_\_

**DEPARTMENT OF ELECTRICAL AND ELECTRONICS ENGINEERING**

---

*Empowering youth- Architects of Future World*



**METHODIST**  
**COLLEGE OF ENGINEERING & TECHNOLOGY**  
(An UGC-AUTONOMOUS INSTITUTION)



Estd : 2008

Accredited by NAAC with A+ and NBA  
Affiliated to Osmania University & Approved by AICTE

## VISION

To produce ethical, socially conscious and innovative professionals who would contribute to sustainable technological development of the society.

## MISSION

To impart quality engineering education with latest technological developments and interdisciplinary skills to make students succeed in professional practice.

To encourage research culture among faculty and students by establishing state of art laboratories and exposing them to modern industrial and organizational practices.

To inculcate humane qualities like environmental consciousness, leadership, social values, professional ethics and engage in independent and lifelong learning for sustainable contribution to the society.



**METHODIST**  
**COLLEGE OF ENGINEERING & TECHNOLOGY**  
(An UGC-AUTONOMOUS INSTITUTION)

Estd : 2008

Accredited by NAAC with A+ and NBA  
Affiliated to Osmania University & Approved by AICTE



# **DEPARTMENT OF ELECTRICAL AND ELECTRONICS ENGINEERING**

## **LABORATORY MANUAL**

### **ELEMENTS OF ELECTRICAL & ELECTRONICS ENGINEERING LABORATORY**

**Prepared**

**By**

Mr. E.Saidulu,

Assistant Professor



**METHODIST**  
**COLLEGE OF ENGINEERING & TECHNOLOGY**  
(An UGC-AUTONOMOUS INSTITUTION)



Estd : 2008

Accredited by NAAC with A+ and NBA  
Affiliated to Osmania University & Approved by AICTE

## DEPARTMENT OF ELECTRICAL AND ELECTRONICS ENGINEERING

### VISION

To become a reputed centre for imparting quality education in Electrical and Electronics Engineering with human values, ethics and social responsibility.

### MISSION

- To impart fundamental knowledge of Electrical, Electronics and Computational Technology.
- To develop professional skills through hands-on experience aligned to industry needs.
- To undertake research in sunrise areas of Electrical and Electronics Engineering.
- To motivate and facilitate individual and team activities to enhance personality skills.



**METHODIST**  
**COLLEGE OF ENGINEERING & TECHNOLOGY**  
(An UGC-AUTONOMOUS INSTITUTION)



Estd : 2008

Accredited by NAAC with A+ and NBA  
Affiliated to Osmania University & Approved by AICTE

## DEPARTMENT OF ELECTRICAL AND ELECTRONICS ENGINEERING

### PROGRAM EDUCATIONAL OBJECTIVES

BE-Electrical Engineering graduates shall be able to:

- **PEO1.** Utilize domain knowledge required for analyzing and resolving practical Electrical Engineering problems.
- **PEO2.** Willing to undertake inter-disciplinary projects, demonstrate the professional skills and flair for investigation.
- **PEO3.** Imbibe the state of the art technologies in the ever transforming technical scenario.
- **PEO4.** Exhibit social and professional ethics for sustainable development of the society.



**METHODIST**  
**COLLEGE OF ENGINEERING & TECHNOLOGY**  
(An UGC-AUTONOMOUS INSTITUTION)

Estd : 2008

Accredited by NAAC with A+ and NBA  
Affiliated to Osmania University & Approved by AICTE



## DEPARTMENT OF ELECTRICAL AND ELECTRONICS ENGINEERING

### PROGRAM OUTCOMES

Engineering Graduates will have ability to:

- **PO1. Engineering knowledge:** Apply the knowledge of mathematics, science, engineering fundamentals, and an engineering specialization to the solution of electrical and electronics engineering problems.
- **PO2. Problem analysis:** Identify, formulate, review research literature, and analyze complex electrical and electronics engineering problems reaching substantiated conclusions using first principles of mathematics, natural sciences, and engineering sciences.
- **PO3. Design/development of solutions:** Design solutions for complex electrical and electronics engineering problems and design system components or processes that meet the specified needs with appropriate consideration for the public health and safety, and the cultural, societal, and environmental considerations.
- **PO4. Conduct investigations of complex problems:** Use research-based knowledge and research methods including design of experiments, analysis and interpretation of data, and synthesis of the information to provide valid conclusions.
- **PO5. Modern tool usage:** Create, select, and apply appropriate techniques, resources, and modern engineering and IT tools including prediction and modelling to complex electrical and electronics engineering activities with an understanding of the limitations.
- **PO6. The engineer and society:** Apply reasoning informed by the contextual knowledge to assess societal, health, safety, legal and cultural issues and the consequent responsibilities relevant to the professional electrical and electronics engineering practice.
- **PO7. Environment and sustainability:** Understand the impact of the professional engineering solutions in societal and environmental contexts, and demonstrate the knowledge of, and need for sustainable development.
- **PO8 Ethics:** Apply ethical principles and commit to professional ethics and responsibilities and norms of the electrical and electronics engineering practice.
- **PO9. Individual and team work:** Function effectively as an individual, and as a member or leader in diverse teams, and in multidisciplinary settings.
- **PO10. Communication:** Communicate effectively on complex engineering activities with the engineering community and with society at large, such as, being able to comprehend and write effective reports and design documentation, make effective presentations, and give and receive clear instructions.
- **PO11. Project management and finance:** Demonstrate knowledge and understanding of the engineering and management principles and apply these to one's own work, as a member and leader in a team, to manage projects and in multidisciplinary environments.
- **PO12. Life-long learning:** Recognize the need for, and have the preparation and ability to engage in independent and life-long learning in the broadest context of technological change.

### PROGRAM SPECIFIC OUTCOMES

At the end of B.E program Electrical and Electronics Engineering graduates will be able to:

- **PSO1.** Provide effective solutions in the fields of Power Electronics, Power Systems and Electrical Machines using MATLAB/MULTISIM.
- **PSO2.** Design and develop various Electrical and Electronics Systems, particularly Renewable Energy Systems.
- **PSO3.** Demonstrate the overall knowledge and contribute for the betterment of the society.



## DEPARTMENT OF ELECTRICAL AND ELECTRONICS ENGINEERING

### I. PREREQUISITE(S):

| Level | Credits | Semester | Prerequisites                                    |
|-------|---------|----------|--|
| UG    | 1       | 1        | Elements of Electrical & Electronics Engineering |

### II. SCHEME OF INSTRUCTIONS:

| Lectures | Tutorials | Practicals | Credits |
|----------|-----------|------------|---------|
| 0        | 0         | 2          | 1       |

### III. SCHEME OF EVALUATION & GRADING:

| S. No        | Component   | Duration | Maximum Marks |
|--------------|---|----------|---------------|
|              | <b>Continuous Internal Evaluation (CIE)</b>                 |          |               |
| 1.           | Internal Examination – I and II                             |          |               |
|              | <b>CIE (Total)</b>  |          |               |
| 2.           | <b>Semester End Examination</b><br>(University Examination) |          |               |
| <b>TOTAL</b> |   |          |               |

|                      |      |            |            |            |            |            |      |        |
|----------------------|------|------------|------------|------------|------------|------------|------|--------|
| <b>% Marks Range</b> | >=90 | 80 to < 90 | 70 to < 80 | 60 to < 70 | 50 to < 60 | 40 to < 50 | < 40 | Absent |
| <b>Grade</b>         | S    | A          | B          | C          | D          | E          | F    | Ab     |
| <b>Grade Point</b>   | 10   | 9          | 8          | 7          | 6          | 5          | 0    | -      |







**METHODIST**  
**COLLEGE OF ENGINEERING & TECHNOLOGY**  
(An UGC-AUTONOMOUS INSTITUTION)



Estd : 2008

Accredited by NAAC with A+ and NBA  
Affiliated to Osmania University & Approved by AICTE

## DEPARTMENT OF ELECTRICAL AND ELECTRONICS ENGINEERING

### LABORATORY CODE OF CONDUCT

1. Students should report to the labs concerned as per the scheduled time table.
2. Students, who report late to the labs, will not be permitted to perform the experiment scheduled for the day.
3. Students to bring a 100 pages note book to enter the readings /observations while performing the experiment.
4. After completion of the experiment, certification of the staff in-charge concerned, in the observation book is necessary.
5. Staff member in-charge shall evaluate for --- marks, each experiment, based on continuous evaluation which will be entered in the continuous internal evaluation sheet.
6. The record of observations, along with the detailed procedure of the experiment performed in the immediate previous session should be submitted for certification by the staff member in-charge.
7. Not more than three students in a group would be permitted to perform the experiment on the equipment-based lab set up. However only one student is permitted per computer system for computer-based labs.
8. The group-wise division made at the start of the semester should be adhered to, and no mix up with any other group would be allowed.
9. The components required, pertaining to the experiment should be collected from the stores in-charge, after duly filling in the requisition form / log register.
10. After the completion of the experiment, students should disconnect the setup made by them, and return all the components / instruments taken for the purpose, in order.
11. Any damage of the equipment or burn-out of components will be charged at cost as a penalty or the total group of students would be dismissed from the lab for the semester/year.
12. Students should be present in the lab for the total time duration, as scheduled.
13. Students are required to prepare thoroughly, before coming to Laboratory to perform the experiment.
14. Procedure sheets / data sheets provided to the students, if any, should be maintained neatly and returned after the completion of the experiment.



**METHODIST**  
**COLLEGE OF ENGINEERING & TECHNOLOGY**  
(An UGC-AUTONOMOUS INSTITUTION)



Estd : 2008

Accredited by NAAC with A+ and NBA  
Affiliated to Osmania University & Approved by AICTE

## DEPARTMENT OF ELECTRICAL AND ELECTRONICS ENGINEERING

### DO's AND DON'Ts IN THE LABORATORY

#### Do's:

1. Always check to see that the power switch is OFF before plugging into the outlet.
2. Also, turn instrument or equipment OFF before unplugging from the outlet.
3. The lab timetable must be followed strictly.
4. Be PUNCTUAL for your laboratory session.
5. Experiment must be completed within the given time.
6. Noise must be kept to a minimum.
7. Handle all apparatus with care.
8. All bags must be left at the indicated place.
9. Shoes and apron must be worn at all times.
10. Be as neat as possible. Keep the work area and workbench clear of items not used in the experiment.

#### Don'ts:

1. No ungrounded electrical or electronic apparatus is to be used in the laboratory unless it is double insulated or battery operated.
2. When unplugging a power cord, pull on the plug, not on the cable.
3. Students are strictly PROHIBITED from taking out any items from the laboratory.

#### Before Leaving Lab:

- Return all the equipment to authority concerned.
- Switch off the main power to the lab bench.
- Please check the laboratory notice board regularly for updates.



## DEPARTMENT OF ELECTRICAL AND ELECTRONICS ENGINEERING

### CONTENTS

| Sl. No.                       | Name of Experiment   | Page No. |
|-------------------------------|--|----------|
| 1                             | Verification of KVL, KCL, Superposition Theorem.   |          |
| 2                             | Verification of Thevenin's and Norton's Theorems.  |          |
| 3                             | Loading of transformer- measurement of primary and Secondary voltages and currents and power.  |          |
| 4                             | Three phase transformers- star and delta connections. Voltage and current relations.   |          |
| 5                             | OCC characteristics of DC Generator.   |          |
| 6                             | Load test on DC shunt Motor.   |          |
| 7                             | Measurement of phase voltage/ current, line voltage/current and power in a balanced three phase circuit connected in star and delta. |          |
| 8                             | V-I Characteristics of silicon and Germanium diodes and measurement of static and dynamic resistances.                               |          |
| 9                             | V-I Characteristics of silicon and Germanium diodes of Zener diode and measurement of static and dynamic resistances.                |          |
| 10                            | Input and output Characteristics of BJT in CB configuration.   |          |
| <b>Additional Experiments</b> |  |          |
| 11                            | Swinburne's test.  |          |
| 12                            | OC & SC test on 1- $\Phi$ transformer.   |          |

## Expt. No.1.Verification of KVL and KCL, Superposition theorem

### (a) Verification of Kirchhoff's Law:

**Aim:** To verify Kirchhoff's Current law (KCL) and Kirchhoff's Voltage law (KVL).

#### **Apparatus:**

| S. No | Equipment Name               | Type      | Range       | Qty.        |
|-------|------------------------------|-----------|-------------|-------------|
| 1     | Regulated power supply (RPS) | DC supply | (0 – 30) V  | 1 No        |
| 2     | Voltmeter (V)                | MC        | (0 – 30) V  | 3 No        |
| 3     | Ammeter (A)                  | MC        | (0 – 20) mA | 3 No        |
| 4     | Resistors (R)                |           |             |             |
| 5     | Connecting wires             |           |             | As per req. |
| 6     | Connecting wires             |           |             | As per req. |

#### **Theory:**

Kirchhoff's laws relate the currents at various junctions and voltages across various components in a closed circuit. The current law emphasises **the law of conservation of charge**, where as the voltage law establishes **the law of conservation of energy**.

#### **KVL:**

It states that **“The algebraic sum of voltages drop (product of current and resistance in each of the component) in any closed path (or mesh) in a network and the algebraic sum of voltage rise of the E.m.f s in that path is zero.”**

#### **KCL:**

It states that **“The algebraic sum of currents entering and leaving at a node (or junction) is equal to zero.”**

## Circuit diagrams:

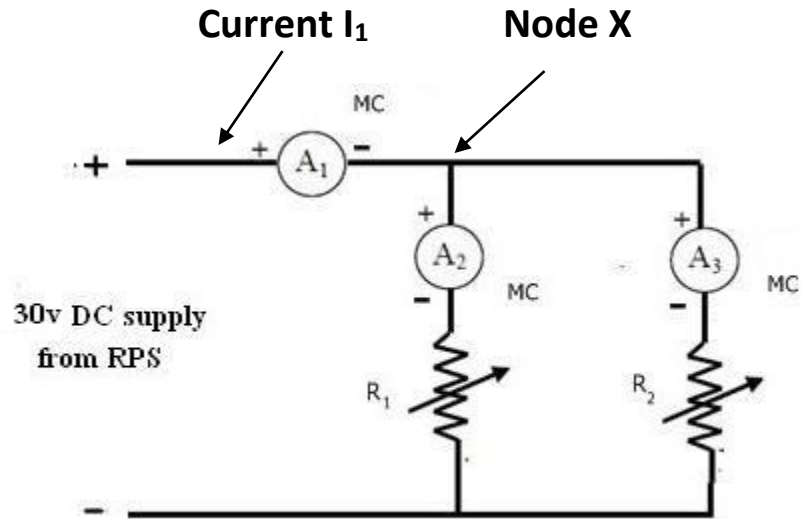

Fig.1

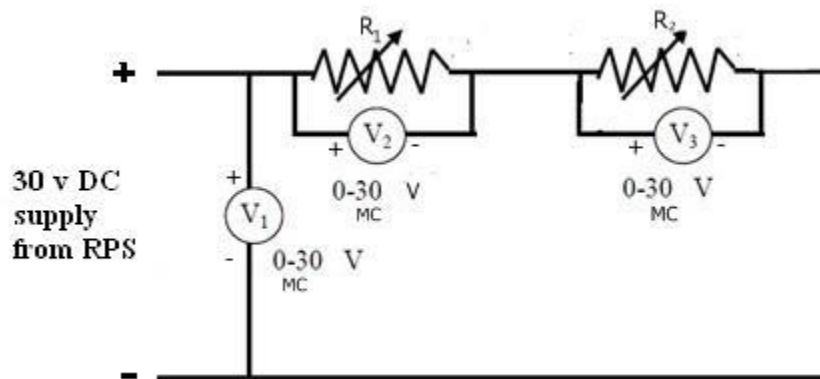

Fig.2

## Procedure:

### KCL:

1. Arrange all the resistors on the bread board as per the circuit diagram of Fig.1.
2. SET the RPS, between 0 V and 30 V.
3. The ammeter measures the current flowing through the resistor. Let  $I_1$  be the current, as read by Ammeter  $A_1$ , current  $I_2$  read by ammeter  $A_2$  and current  $I_3$  read by ammeter  $A_3$ .
4. Note down the readings of the three ammeters.
5. Increase the RPS in suitable step and complete steps 3, 4, till RPS is max at 30 V.
6. KCL is verified at the NODE X, when  $I_1 = I_2 + I_3$

**KVL:**

1. Arrange all the resistors on the bread board as per the circuit diagram of Fig.2.
2. SET the RPS, between 0 V and 30 V.
3. Measure the Voltage across the resistors using the Voltmeter.
4. Note down the readings of the three voltmeters  $V_1$ ,  $V_2$  and  $V_3$
5. By convention, Voltage rise is +ve, and Voltage drop is - ve.
6. Increase the RPS in suitable step and complete steps 3, 4, till RPS is max at 30 V.
7. KVL is verified when  $V_1 = V_2 + V_3$ .

**Tabular form:**

**KCL:**

| S.NO. | Ammeter ( $A_1$ ) | Ammeter ( $A_2$ ) | Ammeter ( $A_3$ ) |
|-------|-------------------|-------------------|-------------------|
| 1     |                   |                   |                   |
| 2     |                   |                   |                   |
| 3     |                   |                   |                   |

**KVL :**

| S.NO. | Voltmeter ( $V_1$ ) | Voltmeter ( $V_2$ ) | Voltmeter ( $V_3$ ) |
|-------|---------------------|---------------------|---------------------|
| 1     |                     |                     |                     |
| 2     |                     |                     |                     |
| 3     |                     |                     |                     |

**Precautions:**

1. Avoid touching the equipment when the power supply is in ON condition.
2. Avoid loose connections.

**Result:**

**Viva Questions:**

1. What is the ohm's law?
2. Define KCL & KVL.
3. What is the use of Regulated power supply?
4. How we will verify the Kirchhoff's laws.

**(b) Verification of Superposition Theorem:**

**Aim:** To verify Superposition theorem.

**Apparatus:**

| S. No | Equipment Name               | Type      | Range       | Qty.        |
|-------|------------------------------|-----------|-------------|-------------|
| 1     | Regulated power supply (RPS) | DC supply | (0 – 30) V  | 2 No        |
| 2     | Ammeter (A)                  | MC        | (0 – 20) mA | 3 No        |
| 3     | Resistors ( R )              |           |             |             |
| 4     | Breadboard                   |           |             | 1 No        |
| 5     | Connecting wires             |           |             | As per req. |

**Circuit Diagram:**

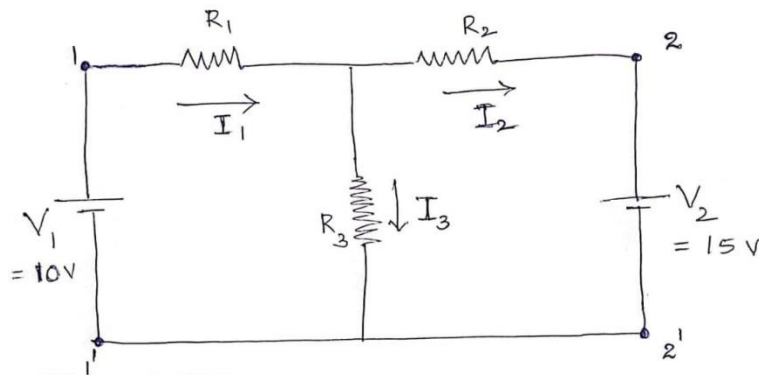

**Theory:** If a network contains two or more sources, then principle of superposition theorem is used to simplify network calculations, which can be stated as follows: In a bilateral network if two or more energy sources are present, then the current at any point is the algebraic sum of all currents , which would flow at that point, if each source was considered separately and all other sources replaced by their internal resistances.

### Procedure:

1. Connect D.C power supply across terminals 1-1<sup>1</sup> and apply voltage of say  $V_1=10$  volts and similarly across terminals 2-2<sup>1</sup> apply voltage of say  $V_2=15$  volts.
2. Measure current flowing through all branches, say these currents are  $I_1$ ,  $I_2$ , and  $I_3$ .
3. Now connect only  $V_1=10$  volts across terminals 1-1<sup>1</sup> and short circuit terminals 2-2<sup>1</sup> that is  $V_2=0$  volts.
4. Measure currents flowing through all branches for  $V_1=10$  volts  $V_2=0$  volts using a milliammeter, let these currents be  $I_1'$ ,  $I_2'$ ,  $I_3'$ .
5. Similarly connect only  $V_2=15$  volts across terminals 2-2<sup>1</sup> and short circuit terminals 1-1<sup>1</sup> that is  $V_1=0$  volts.
6. Measure current flowing through all branches for  $V_1=0$  volts and  $V_2=15$  volts using a milliammeter, let these currents be  $I_1''$ ,  $I_2''$ ,  $I_3''$ .
7. For verifying superposition theorem  $I_1= I_1' + I_1''$ ,  $I_2= I_2' + I_2''$ ,  $I_3=I_3' + I_3''$ .
8. Calculate theoretical values of currents, these values should be approximately equal to measured values of currents.

### Tabular form:

| S.NO | $V_1=10$ V<br>$V_2=15$ V | $V_1=10$ V<br>$V_2=0$ V | $V_1=0$ V<br>$V_2=15$ V |
|------|--------------------------|-------------------------|-------------------------|
| 1    | $I_1=$                   | $I_1'=$                 | $I_1''=$                |
| 2    | $I_2=$                   | $I_2'=$                 | $I_2''=$                |
| 3    | $I_3=$                   | $I_3'=$                 | $I_3''=$                |

### Theoretical Calculations:

### Result:

### Viva Questions:

1. Explain statement of superposition theorem?
2. What are the Applications of superposition theorem?
3. How we will compare those theoretical and practical values?
4. Why are we taking two sources in this theorem? Can there be many sources?









## **Expt. No. 2.Verification of Thevenin's and Norton's Theorem**

**Aim:** To Verify Thevenin's theorem for the given DC Circuit.

**Apparatus:**

| S.No | Equipment Name                | Type      | Range         | Qty.        |
|------|-------------------------------|-----------|---------------|-------------|
| 1    | Regulated power supply ( RPS) | DC supply | (0 – 30) V,2A | 1 No        |
| 2    | Voltmeter ( V )               | MC        | (0 – 30) V    | 2 No        |
| 3    | Ammeter ( A )                 | MC        | (0 – 20) mA   | 2 No        |
| 4    | Resistors ( R )               |           |               |             |
| 5    | Breadboard                    |           |               | 1 No        |
| 6    | multimeter                    | Digital   |               | 1 No        |
| 7    | Connecting wires              |           |               | As per req. |

**Theory:**

**Thevenin's Theorem:**

This theorem is applied to find the correct values of Voltages and currents in a restricted portion of networks rather than in all the branches of the network.

**Statement:**

“Any linear two terminal network can be replaced by an equivalent network consisting of a voltage source ( $V_{Th}$ ) in series with a resistance ( $R_{Th}$ ) .Where,  $V_{Th}$  = Open circuit voltage at load terminals.  
 $R_{Th}$  = Equivalent resistance at load terminal when sources are made in operative”.

**Circuit Diagrams:**

**(i) To measure Thevenin's Voltage ( $V_{TH}$ ):**

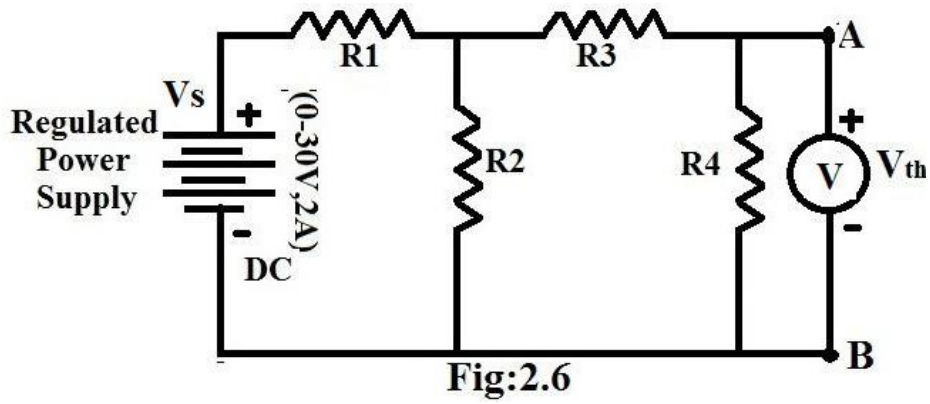

**(ii) To measure Thevenin's Resistance ( $R_{TH}$ ):**

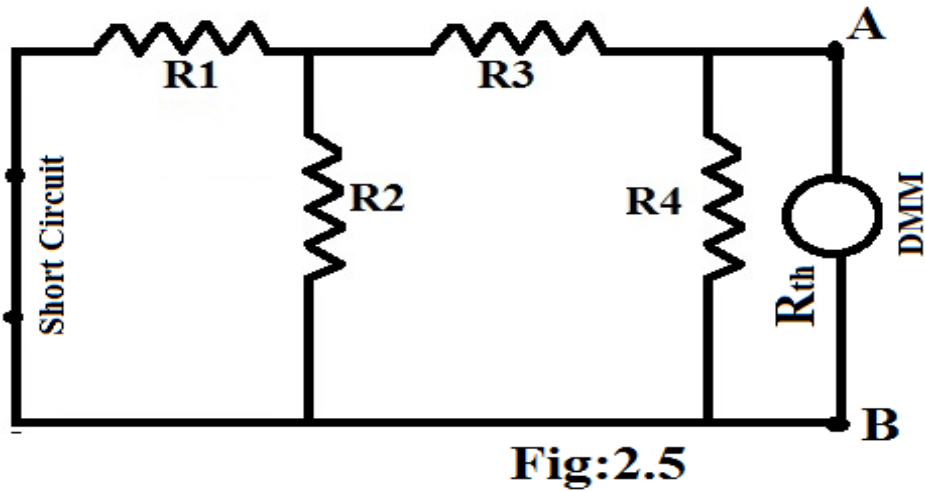

**(iii) To measure Load Current ( $I_L$ ):**

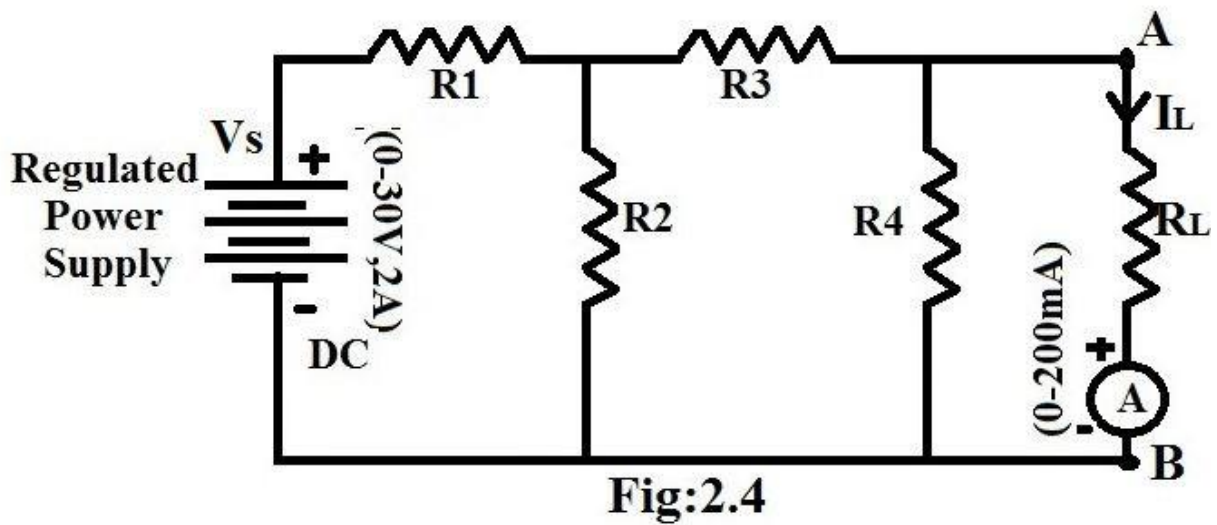

**(iv) Verification Circuit:**

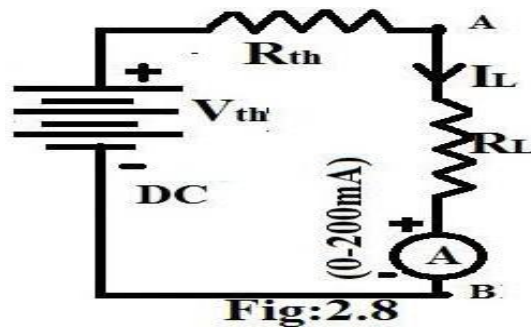

**Procedure:**

1. To find Load Current ( $I_L$ ), Apply the supply voltage  $V_s = 5V$  by using Regulated Power Supply and Find the load current ( $I_L$ ) through the load resistance with circuit as shown in Fig 2.4.
2. To find Thevenin's Resistance ( $R_{th}$ ), Short circuit the Voltage Source in the given circuit as shown in Fig 2.5 and find out the Thevenin's resistance across open circuited terminals after removing the Load Resistance with the help Digital Multimeter (DMM).
3. To find Thevenin's Voltage ( $V_{th}$ ), Apply voltage  $V_s = 5V$  at the source terminals and remove the load Resistance, find the voltage across the open circuited terminals as shown in Fig: 2.6. Note down the applied voltage and Thevenin's voltage.
4. Verify the Thevenin's Theorem by finding the load current with Thevenin's Equivalent circuit as Shown in Fig: 2.8
5. Repeat the above Procedure for Supply Voltages of 10V, 15V, 20V, 25V and Tabulate the Values.

**Theoretical Calculations:**

**Tabular form:**

Thevenin's Theorem:

| S.No | Voltage (Volts)        | Vth (Volts) | IL (Amps) | Rth (Ohms) | IL(Amps)<br>Verification |
|------|------------------------|-------------|-----------|------------|--------------------------|
| 1    | 5V,10V,15V,20V,<br>25V |             |           |            |                          |

**Result:**

**Viva Questions:**

1. What is the difference between a current source and a voltage source?
2. Solve the above circuit using Thevenin's theorem?
3. Explain statement of Thevenin's Theorem?
4. Advantages of Thevenin's Theorem?
5. How we will verify this above theorem?

**Aim:** To Verify Norton’s theorem for the given DC Circuit.

**Apparatus:**

| S. No | Equipment Name                | Type      | Range       | Qty.        |
|-------|-------------------------------|-----------|-------------|-------------|
| 1     | Regulated power supply ( RPS) | DC supply | (0 – 30) V  | 1 No        |
| 2     | Voltmeter ( V )               | MC        | (0 – 30) V  | 1 No        |
| 3     | Ammeter ( A )                 | MC        | (0 – 20) mA | 1 No        |
| 4     | Resistors ( R )               |           |             |             |
| 5     | Breadboard                    |           |             | 1 No        |
| 6     | Connecting wires              |           |             | As per req. |

**Theory:**

**Norton’s Theorem:** It states that “Any two terminal network between A and B can be replaced by an equivalent circuit consisting of a Current Source  $I_N$  in series with a resistance  $R_N$  where  $I_N$  is the short circuit current across the terminals,  $R_N$  is the equivalent resistance at the terminals when Voltage Source is Short Circuited and Current Source is Open Circuited”.

**Circuit Diagrams:**

(i) **To measure Norton’s Current ( $I_N$ ):**

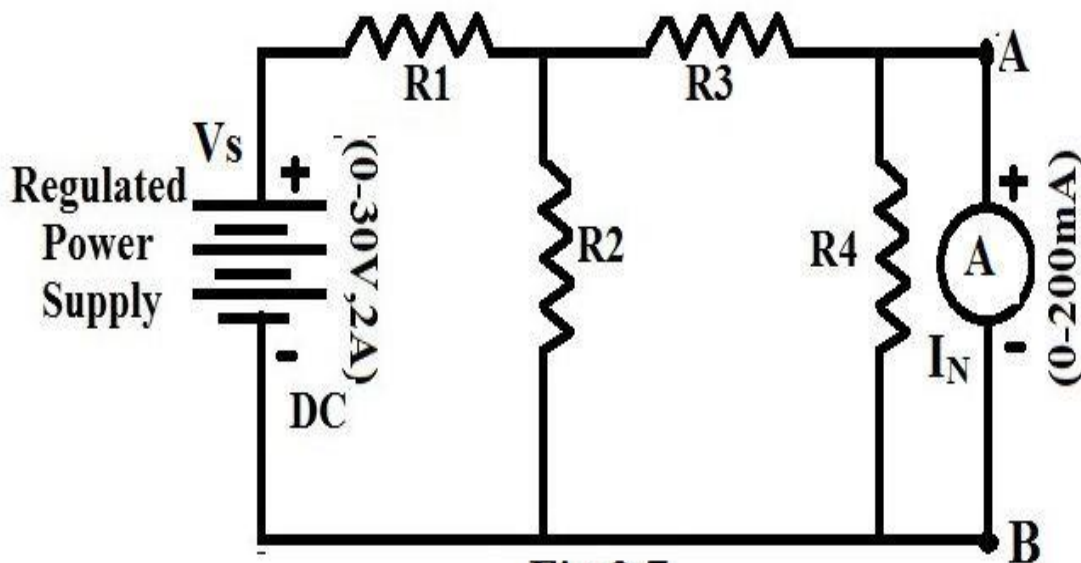

**Fig:2.7**

(ii) To measure Norton's Resistance ( $R_N$ ):  $R_{TH} = R_N$

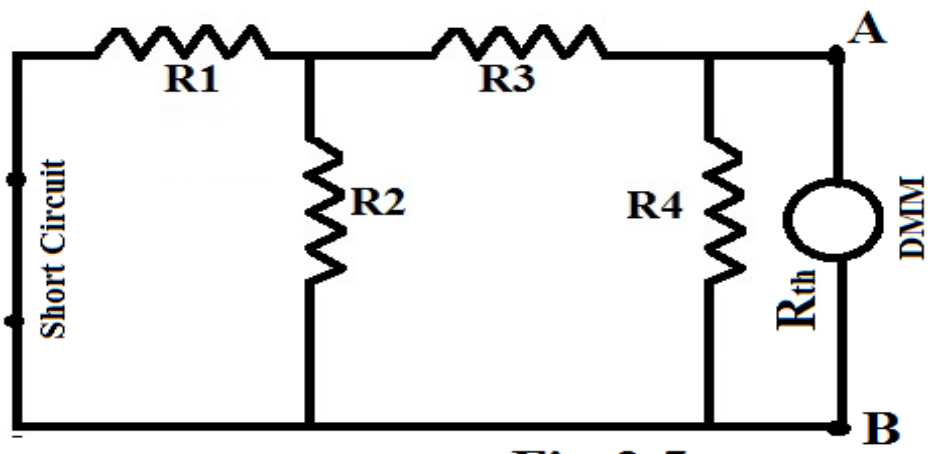

**Fig:2.5**

(iii) To measure Load Current ( $I_L$ ):

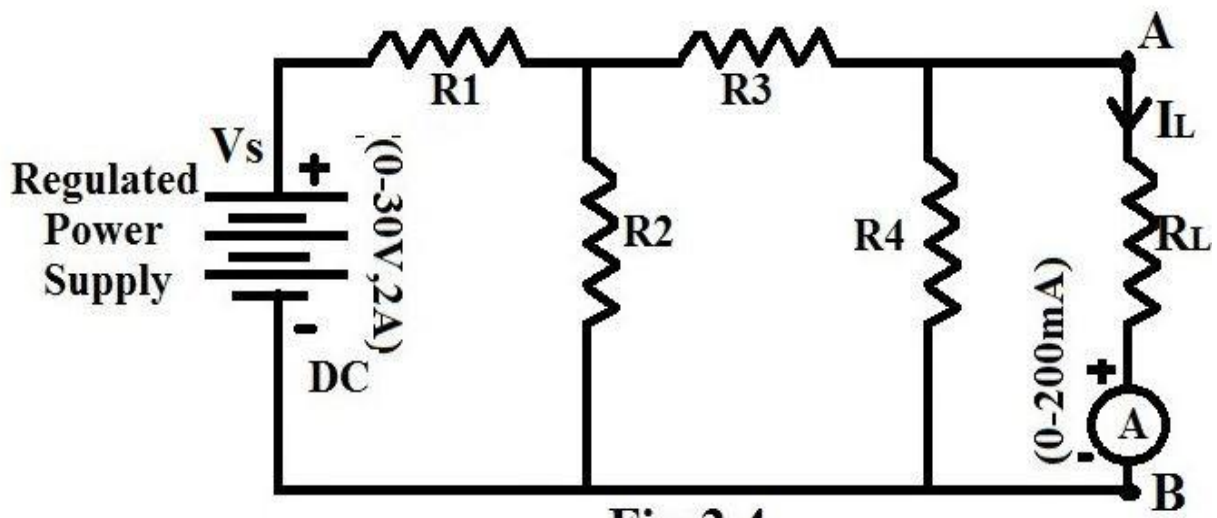

**Fig:2.4**

(iv) Verification Circuit:

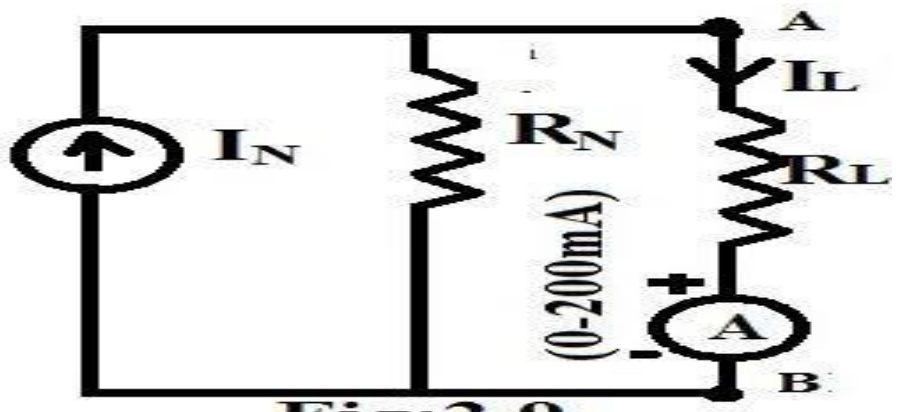

**Fig:2.9**



### **Procedure:**

1. Connect the circuit as shown in Fig: 2.7 and by applying supply voltage  $V_S=5V$  through RPS, determine the short circuit current ( $I_N$  or  $I_{sc}$ ).
2. Note down Norton's resistance  $R_N$  as same as Thevenin's Resistance ( $R_{th}$ ).
3. Verify the Norton's Theorem by finding the load current with Norton's Equivalent circuit as shown In Fig: 2.9.
4. Repeat the above Procedure for Supply Voltages of 10V, 15V, 20V, 25V and Tabulate the Values.

### **Tabular form:**

| S. No | $V_S$<br>(V) | $I_L$ (mA) | $R_{Th}$<br>or $R_N$<br>(Ohms) | $I_N$ (mA) | $I_L$ (mA) using<br>Norton's circuit |
|-------|--------------|------------|--------------------------------|------------|--------------------------------------|
| 1     | 5            |            |                                |            |                                      |
| 2     | 10           |            |                                |            |                                      |
| 3     | 15           |            |                                |            |                                      |
| 4     | 20           |            |                                |            |                                      |
| 5     | 25           |            |                                |            |                                      |

### **Precautions:**

1. Avoid the loose connections.
2. While Conducting the Experiment keep the Current knob of RPS (Regulated Power Supply) at maximum position and Voltage knobs of RPS at minimum position.

### **Theoretical Calculations:**

### **Result:**

### **Viva Questions:**

1. What is the difference between a current source and a voltage source?
2. Solve the above circuit using Norton's theorem?
3. Explain statement of Norton's theorem?
4. Advantages of Norton's theorem?
5. How we will verify this above theorem?









### Expt. No.3.Loading of a Transformer

**Aim:** To measure primary and secondary voltage, current and power by connecting load on a single phase transformer.

**Apparatus:**

| S. No | Equipment Name   | Range          | Type   | Quantity    |
|-------|------------------|----------------|--------|-------------|
| 1     | Ammeter          | (0 -10A)       | MI     | 1           |
|       |                  | (0-5A)         | MI     | 1           |
| 2     | Voltmeter        | (0 – 150 V)    | MI     | 1           |
|       |                  | (0 – 300 V)    | MI     | 1           |
| 3     | Wattmeter        | (300V, 5A)     | UPF    | 1           |
|       |                  | (150V, 10A)    | UPF    | 1           |
| 4     | Autotransformer  | 1Ø, (0 – 230V) | -      | 1           |
| 5     | Resistive Load   | 2KW, 230V      | -      | 1           |
| 6     | Connecting wires | 2.5 Sq.mm      | Copper | As per req. |

**Name Plate details:**

| S. No | Parameter     | Primary | Secondary |
|-------|---------------|---------|-----------|
| 1     | Rated Voltage |         |           |
| 2     | Rated Current |         |           |
| 3     | Rated Power   |         |           |

**Theory:**

A transformer operates on the principle of “**Electromagnetic induction**”. It is a TWO winding Equipment, which has “ELECTRICALLY ISOLATED, MAGNETICALLY COUPLED Windings. The Windings are placed on a supporting structure called the CORE which is made up of material of High permeability.

A transformer can be operated to either increase or decrease the voltage on the secondary side, When it is applied to the primary winding. When a transformer is used to “increase” the voltage on It’s secondary winding with respect to the primary, it is called a **Step-up transformer**.

When it is used to “decrease” the voltage on the secondary winding with respect to the primary it is called a **Step-down transformer**.

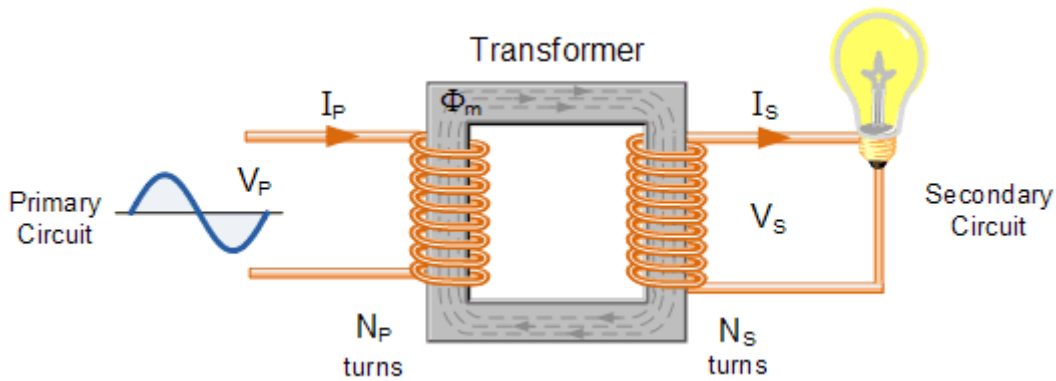
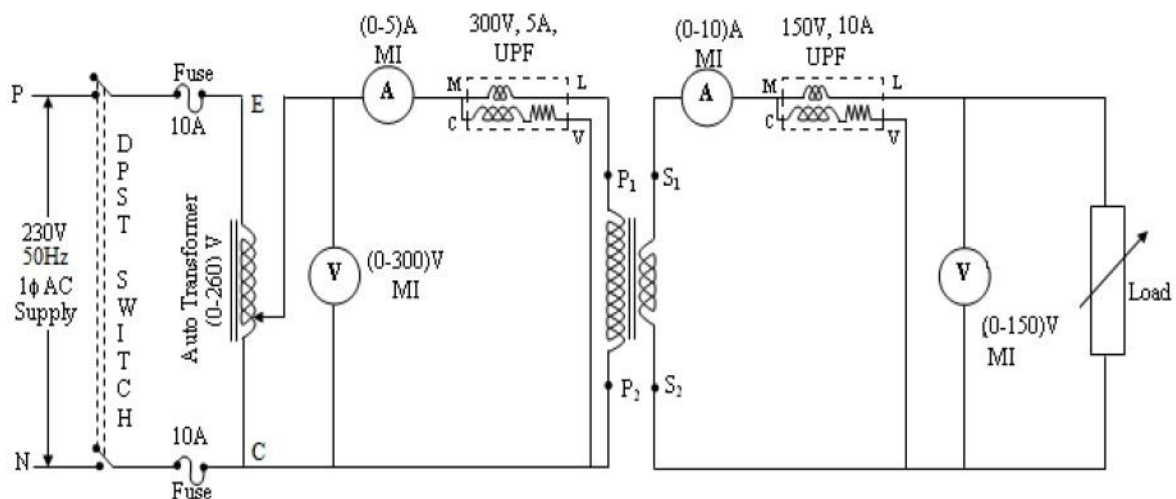

FIG. 1

Where:

- $V_P$  is the Primary Voltage
- $V_S$  is the Secondary Voltage
- $N_P$  is the Number of Primary turns
- $N_S$  is the Number of Secondary turns
- $\Phi$  is the Flux Linkage

**Circuit diagram:**



**Procedure:**

1. Connections are to be made as per the circuit diagram.
2. Double Pole Single Throw (DPST) switch is closed.
3. Under no load condition, ammeter, voltmeter and wattmeter readings on both primary side and Secondary side is noted down.
4. The load is increased in suitable intervals and for each load intervals, corresponding reading of Voltmeter, ammeter and wattmeter on both primary and secondary sides are noted down.
5. The experiment is repeated until the rated current of the transformer (take the minimum rated current Of the transformer primary side) has reached.
6. The load is reduced to bring the transformer to the no load condition. The auto-transformer is brought to its minimum position and then the DPST switch is opened.

**Tabular form:**

| S. No | V <sub>p</sub> | I <sub>p</sub> | W <sub>p</sub> (Watts) | V <sub>s</sub> | I <sub>s</sub> | W <sub>s</sub> (Watts) | % Efficiency (η) |
|-------|----------------|----------------|------------------------|----------------|----------------|------------------------|------------------|
| 1     |                |                |                        |                |                |                        |                  |
| 2     |                |                |                        |                |                |                        |                  |
| 3     |                |                |                        |                |                |                        |                  |
| 4     |                |                |                        |                |                |                        |                  |
| 5     |                |                |                        |                |                |                        |                  |
| 6     |                |                |                        |                |                |                        |                  |
| 7     |                |                |                        |                |                |                        |                  |
| 8     |                |                |                        |                |                |                        |                  |
| 9     |                |                |                        |                |                |                        |                  |
| 10    |                |                |                        |                |                |                        |                  |

**Formulae:**

$$\% \text{Efficiency} = \frac{W_s}{W_p} * 100$$

2.  $E_p / I_p = I_s / E_s$  Under NO- Load Condition,  $V_p$  approx. =  $E_p$  and  $V_s$  approx. =  $E_s$

3.  $V_p * I_p * \cos \phi = W_p$  where  $\cos \phi$  is called the NO Load POWER FACTOR.

4. The ratio  $V_p / I_p = Z_p$  where  $Z_p$  is called the IMPEDANCE on Primary side.

Similarly,

$$V_s / I_s = Z_s.$$

**Precautions:**

1. Auto Transformer should be kept at minimum position.
2. The transformer should be kept under no load condition.
3. The 'M' and 'C' terminal of primary and secondary side watt meters should be shorted.
4. The AC supply is applied and removed from the transformer under no load condition.

**Expected Graph:**

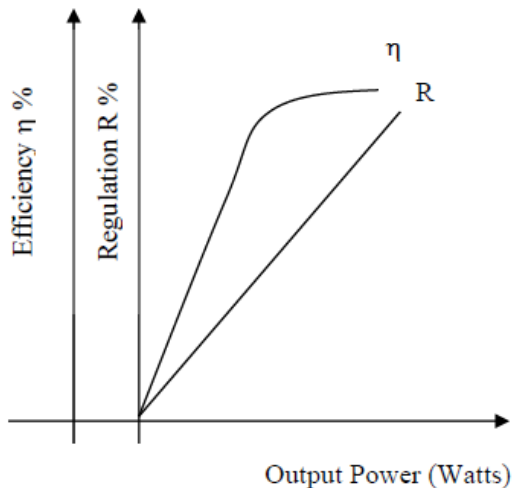



**Sample Calculations:**

**Result:**

**Viva Questions:**

1. What are the applications of a transformer?
2. Define transformer?
3. What do you understand by regulation of a transformer?
4. What is the difference between transformer and auto-transformer?
5. What are the methods of testing a transformer?



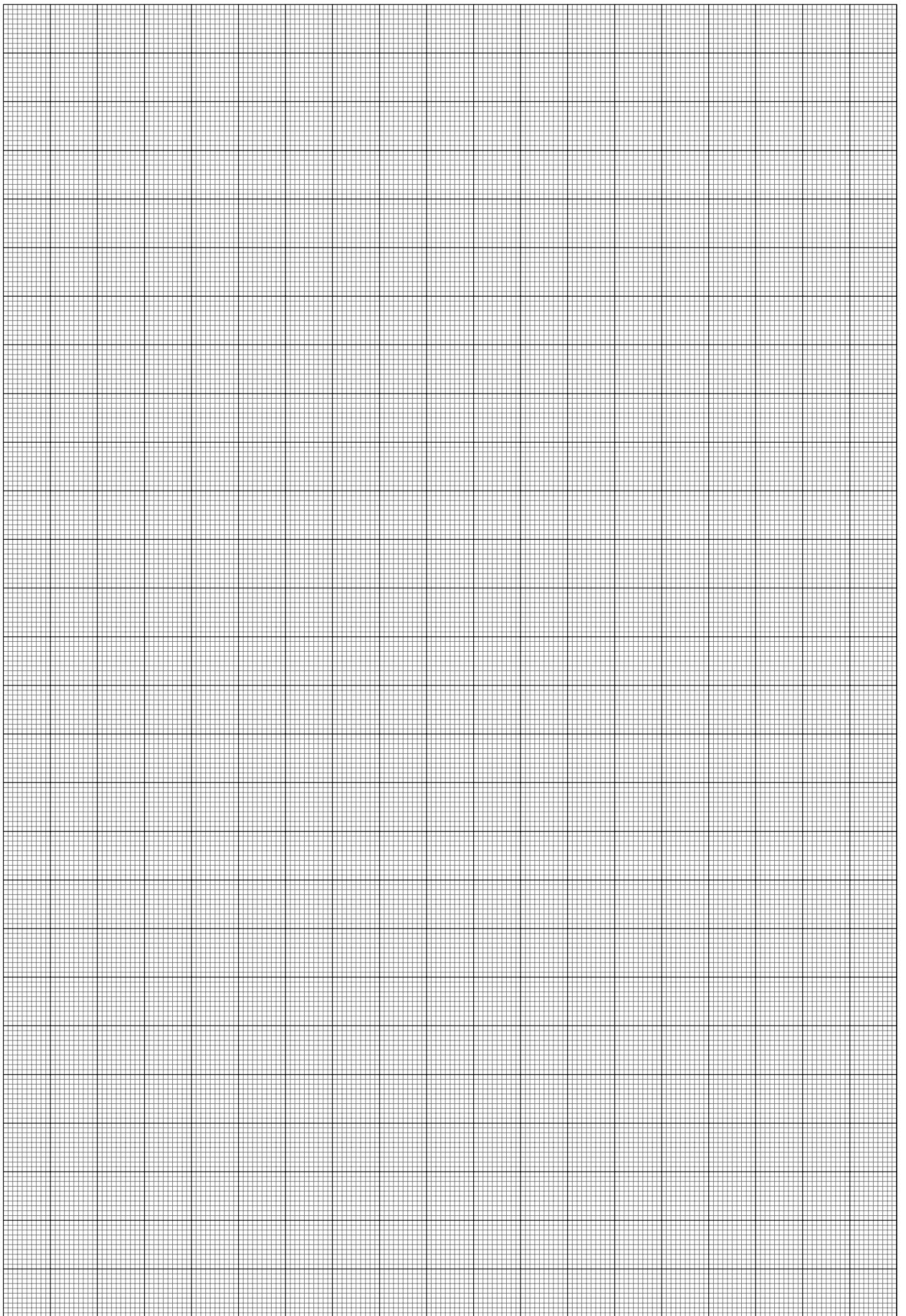

## Expt. No.4. Verify Voltage and Current Relationships of a Three-Phase Transformer in Star and Delta Connections

**Aim:** To Verify Voltage and Current relationships of a Three - Phase transformer in Star and Delta connections (line-line voltage, phase-to-neutral voltage, line and phase currents).

### Apparatus:

| S. No | Equipment Name           | Range                 | Type | Quantity    |
|-------|--------------------------|-----------------------|------|-------------|
| 1     | 3 Phase Transformer      | 440 V                 |      | 1           |
| 2     | 3 Phase Auto Transformer | (0-470/440V),10 A     |      | 1           |
| 3     | Ammeter                  | (0-10A/20) A          | MI   | 1           |
| 4     | Voltmeter                | (0-300) V & (0-6000)V | MI   | 2           |
| 5     | Connecting wires         |                       |      | As per Req. |

### Theory:

- a) Three windings used on a common core , each winding supplied with a voltage differing in Phase is the construction of a 3 phase transformer. There are various methods available for transforming 3-phase voltages to higher or lower 3- $\Phi$  voltages for handling a considerable amount of power. The most common connections are  
(i) Y - Y (ii)  $\Delta$  -  $\Delta$  (iii) Y -  $\Delta$  (iv)  $\Delta$  - Y. Among them Y - Y & Y -  $\Delta$  are predominantly used.

### Wye - Wye or Y - Y Connection:

This connection is economical for large, low-voltage transformers in which insulation problem is Not so urgent, because it increases the number of turns/phase. The ratio of transformation between Primary and secondary line voltage is the same as that of each transformer.

### Wye/Delta or Y- $\Delta$ Connection:

The main use of this connection is at the substation end of the transmission line where the voltage is to be stepped down. The primary winding is Y-connected with grounded neutral. The ratio between the secondary and primary line voltage is  $1/3$  times the transformation ratio of each transformer. There is a  $30^\circ$  shift between the primary and secondary line voltages which means that a Y -  $\Delta$  transformer bank cannot be paralleled with either a Y - Y or a  $\Delta$  -  $\Delta$  bank. Also, 3<sup>rd</sup> harmonic currents flow in the  $\Delta$  to provide a sinusoidal flux.

## Circuit Diagrams:

### Star – Delta Connection:

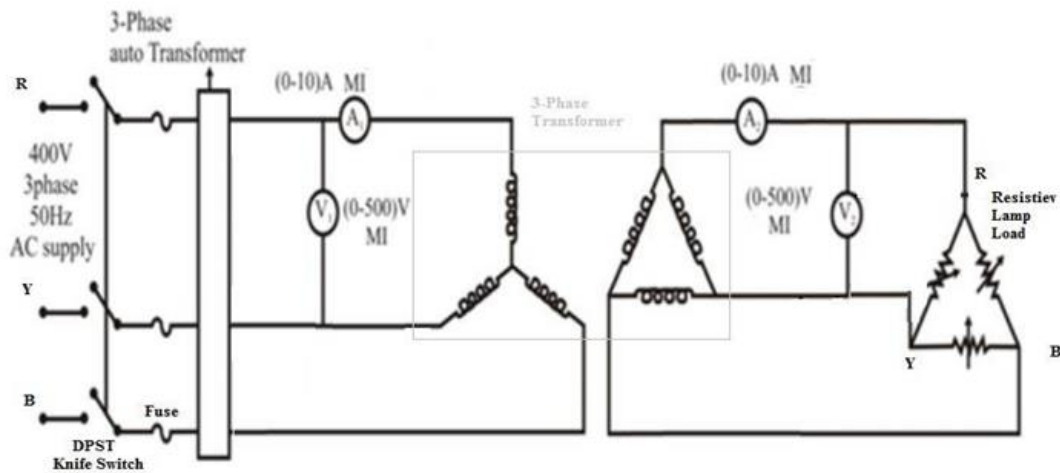

Circuit Diagram  
STAR - DELTA CONNECTION

### Star - Star Connection:

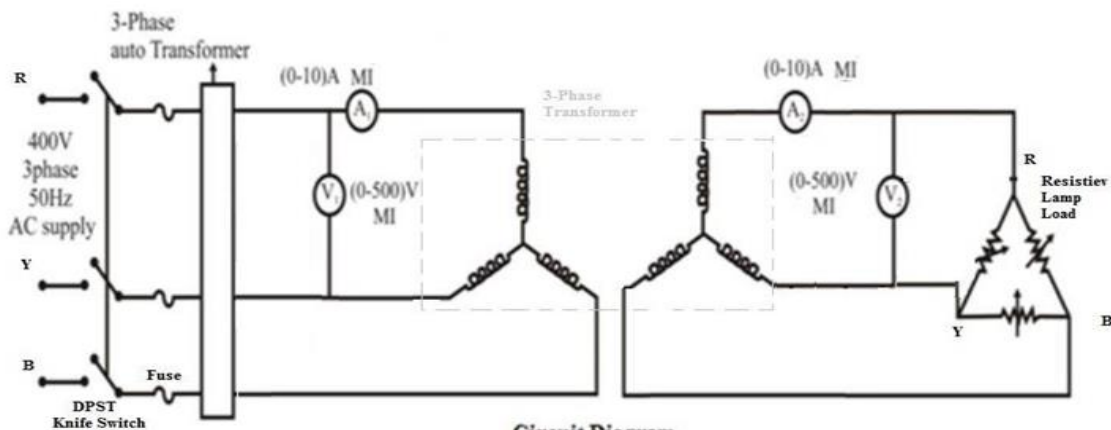

Circuit Diagram  
STAR - STAR CONNECTION

## Procedure:

### Star- Delta Connection:

1. Connections are made as shown in the circuit diagram Fig 1.
2. By keeping 3-  $\emptyset$  auto-transformer voltage in zero position and the 3-phase resistive load in off position, the 3-  $\emptyset$  supply switch is closed.
3. By varying the 3-  $\emptyset$  auto-transformer apply the rated voltage of the transformer (400V).
4. By keeping the 3-  $\emptyset$  resistive load in off position & note down the no-load voltages.
5. Apply the load & all the meter readings are noted down.
6. The resistive load is brought back to its initial minimum position and 3- $\emptyset$  auto-transformer to its initial zero output position, the supply switch is opened.

**Star –Star connection:**

1. Connections are made as shown in the circuit diagram Fig.2.
2. By keeping 3-  $\emptyset$  auto-transformer voltage in zero position and the 3-  $\emptyset$  resistive load in off position, the 3-  $\emptyset$  supply switch is closed.
3. By varying the 3-phase auto-transformer apply the rated voltage of the transformer (**440V**).
4. By keeping the 3-  $\emptyset$  resistive load in off position note down the no-load voltage.
5. Apply the load & all the meter readings are noted down.
6. The resistive loads are brought back to its initial minimum position and 3- $\emptyset$  auto-transformer to its initial zero output position, the supply switch is opened.

**Tabular Forms:**

**For Star-Delta connection:**

| S.NO | Y-Side      |             | $\Delta$ -Side |             |
|------|-------------|-------------|----------------|-------------|
|      | Voltage(V1) | Current(I1) | Voltage(V2)    | Current(I2) |
| 1    |             |             |                |             |
| 2    |             |             |                |             |
| 3    |             |             |                |             |

**For Star-Star connection:**

| S.NO | $\Delta$ -Side |             | Y-Side      |             |
|------|----------------|-------------|-------------|-------------|
|      | Voltage(V1)    | Current(I1) | Voltage(V2) | Current(I2) |
| 1    |                |             |             |             |
| 2    |                |             |             |             |
| 3    |                |             |             |             |

**Result:**

**Viva Questions:**

1. Define transformer?
2. What is the difference between 1- phase transformer and 3-phase transformer?
3. What is the relationship between star and delta connected transformers?
4. What is the use 3-phase transformer?
5. Why we are using R- Load in these circuits, why not we use other loads?



## Expt. No. 5. O.C.C characteristics of a DC Generator

### Aim:

To obtain the open circuit magnetization characteristics (OCC) of a separately excited DC Generator and to Observe the following.

- a) Maximum Voltage built up.
- b) Residual Voltage.

### Name Plate Details:

| S. No | Parameter        | Motor | Generator |
|-------|------------------|-------|-----------|
| 1     | Armature Voltage |       |           |
| 2     | Armature Current |       |           |
| 3     | Field Voltage    |       |           |
| 4     | Field Current    |       |           |
| 5     | Power            |       |           |
| 6     | Wound            |       |           |
| 7     | Rated Speed      |       |           |

### Apparatus:

| S. No | Equipment Name | Range      | Type       | Quantity |
|-------|----------------|------------|------------|----------|
| 1     | Voltmeter      | (0 – 300)V | MC         | 1 No     |
| 2     | Ammeter        | (0 – 2)A   | MC         | 1 No     |
| 3     | Rheostats      | 500Ω/2A    | Wire Wound | 1 No     |
|       |                | 290Ω/1.2A  | Wire Wound | 1 No     |
| 4     | Tachometer     | Digital    |            | 1 No     |

### Theory:

This characteristic is also called as no load characteristic through which the generator performance parameters can be determined. This characteristic gives the value of maximum voltage the generator can give and to avoid the failure of excitation, the field winding resistance value which is called as critical field resistance can be determined. Also, the above parameters at various speeds can be determined. The basic set up for determining the above parameters is that the generator is run on separately excited condition. The basic requirement is that the prime mover, the motor, is run at its rated speed and by varying the generator excitation in steps, the generator



Voltage is noted and the procedure is repeated in forward as well as reverse direction so that an observation can be made such the both the induced values will not be same.  $I_f$  is increased by suitable steps and the corresponding values of  $E_g$  are measured on plotting the relation between  $I_f$  &  $E_g$ , a curve of the form is shown in fig.

Due to residual magnetism in the poles, some e.m.f is generated even when  $I_f = 0$ . Hence the curve starts a little way up. The slight curve at the lower and is due to magnetic inertia. At low flux densities, reluctance of iron path being negligible the first part of the curve is practically straight. OCC for higher speed lie above the shown curve & low speed lie below it.

In a D.C. generator, for any given speed, the induced E.m.f in the armature is directly proportional to the flux per pole.

$$E_g = \frac{\Phi Z N P}{60 A} \text{ volts}$$

Where,

$\Phi$  is the flux per pole in webers,

Z is the no. of conductors in the armature,

N is the speed of the shaft in rpm,

P is the no. of poles and

A is the no. of parallel paths.

A = 2 (wave)

A = p (lap)

### Circuit diagram:

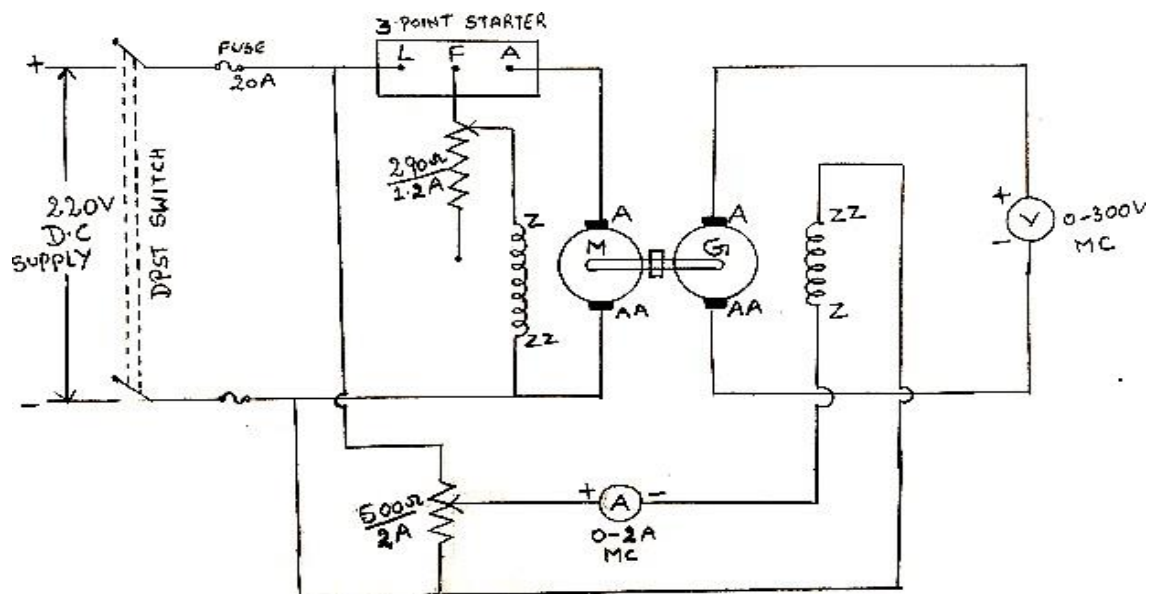

MAGNETISATION CHARACTERISTICS OF A SEPERATELY EXCITED DC GENERATOR

### Fuse Rating:

125% of rated current

Rated current is specified on Name Plate of the Machine.

**Procedure:**

1. Make the connections as per the circuit diagram. Keep the field regulator in the generator field circuit in the maximum resistance position.
2. Start the motor with the starter and note the speed at which the MG set runs.
3. Adjust the field regulator to run the motor at rated speed.
4. A small reading is observed in the voltmeter even though there is no current due to residual magnetism.
5. Vary the field rheostat in the generator circuit and note down the readings of the armature-induced voltage ( $E_g$ ) and field current.
6. Plot the graph between induced voltage ( $E_g$ ) & field current ( $I_f$ ).

**Tabular Forms:**

| S. No | $I_f$ (A) | $E_g$ (V)<br>(increasing) |
|-------|-----------|---------------------------|
| 1     |           |                           |
| 2     |           |                           |
| 3     |           |                           |
| 4     |           |                           |
| 5     |           |                           |
| 6     |           |                           |
| 7     |           |                           |
| 8     |           |                           |

**Expected Graph:**

- Plot the graph between generated voltage ( $E_g$ ) and Field Current ( $I_f$ ).

Draw the field resistance line from the origin such that it is tangent to the ascending curve. The critical field resistance is given by the slope of this tangent.

**Critical field resistance**=Slope of the resistance line which is tangent to the ascending curve.

**Critical Field Resistance:**

The maximum allowed value of the field resistance to a DC shunt generator, above which the voltage fails to build up, is called the Critical Field Resistance.

**Critical Speed:**

It is the speed below which the machine cannot build up E.m.f.

### Expected Graph:

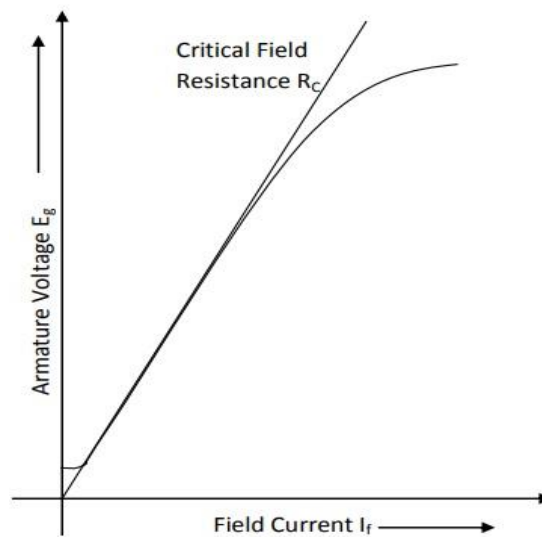

### Precautions:

1. Perform the experiment at constant speed.
2. Readings are to be taken for uniformly increasing and then uniformly decreasing field current.

### Result:

### Viva Questions:

1. What is Residual Voltage?
2. What is Critical Field resistance?
3. What is Critical Speed?
4. What is the difference between separately excited DC Generator and self excited DC Generator.

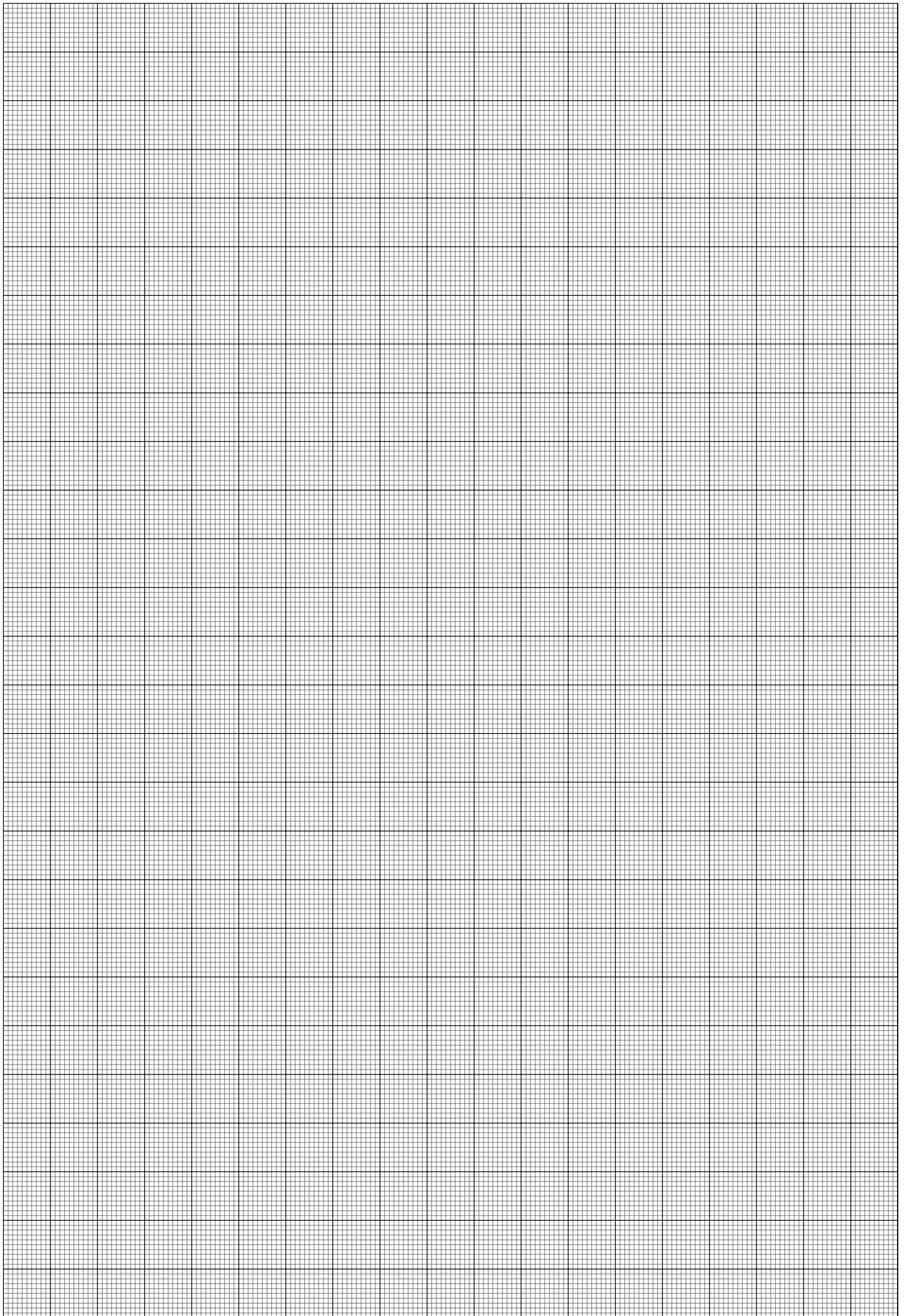

## Expt. No. 6. Load Test on A DC Shunt Motor

**Aim:** To determine the efficiency of a DC shunt motor by conducting brake test.

### **Apparatus:**

| S. No | Equipment Name | Type       | Range           | Qty. |
|-------|----------------|------------|-----------------|------|
| 1.    | Voltmeter      | MC         | 0 – 300V        | 1 No |
| 2.    | Ammeter        | MC         | 0 – 20A         | 1 No |
| 3.    | Ammeter        | MC         | 0 – 1A          | 1 No |
| 4.    | Rheostat       | Wire wound | 290Ω/1.2 A      | 1 No |
| 5.    | Tachometer     | Digital    | (0-2000)<br>rpm | 1 No |

### **Name Plate Details:**

| S. No | Parameter | Motor |
|-------|-----------|-------|
|       |           |       |
|       |           |       |
|       |           |       |
|       |           |       |

### **Theory:**

The precondition to be set for the load test on DC shunt motor is to run the motor at the rated voltage and the rated speed. For Small motors the efficiency can be found directly by a brake test. The loading arrangement done to the motor is that a brake drum is attached to the shaft of the motor and spring balances are connected through which the brake drum is tightened so that the shaft is loaded. This set is said to be called as applied mechanical load. The torque can be determined and speed is measured from which the power output can be calculated. The input to the motor is found by knowing the applied voltage and load current. Hence the efficiency can be known.

Let S1 and S2 are the spring balance readings.

The pull on the brake drum = 9.81 (S1-S2) Newton

Torque on the drum  $T_{sh} = 9.81 (S1-S2) r$  N-m where r is the radius of the drum

Motor power output  $P_{sh} = T_{sh} 2\pi N/60$  watts; where N is the rpm of the motor.

Let input voltage and current be  $V$  and  $I$ , the power input to the motor is  $V \cdot I$

The efficiency  $= \eta = \text{output} / \text{input}$ .

### Circuit diagram:

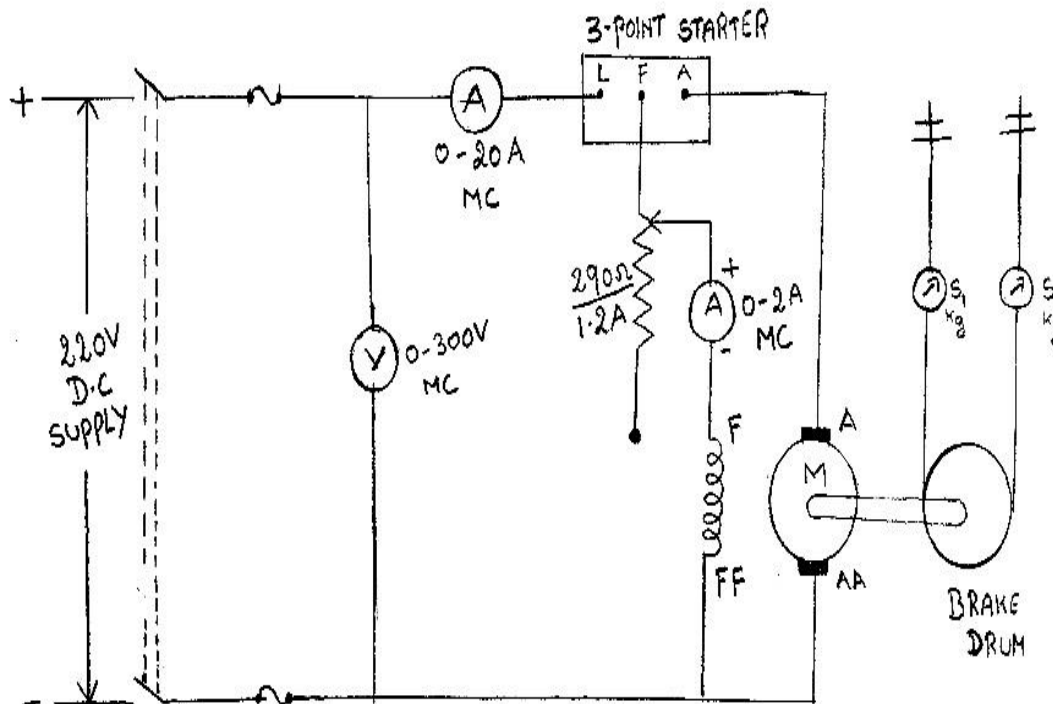

### Procedure:

1. Give the connections as per the circuit diagram.
2. Start the motor using the starter.
3. By varying the field rheostat run the motor at rated speed.
4. Increase the load by tightening the brake band and note the observations of the ammeter, voltmeter, tachometer and the applied loads  $S_1$  and  $S_2$  till rated current is attained. Take at least six readings.
5. Unload the motor by slackening the brake band.
6. Switch off the supply to the motor by opening the DPST switch. Find the radius of the Brake drum.

**Tabular Form:**

| S. No | V (V) | I <sub>L</sub> (A) | I <sub>r</sub> (A) | N (rpm) | S1 (Kg) | S2 (Kg) | W=S1-S2 (Kg) | T= 9.81 W r (Nm) | Output=<br>$\frac{2\pi NT}{60}$<br>(watts) | Input=<br>V I <sub>L</sub><br>(Watts) | $\eta =$<br>Output/<br>Input (%) |
|-------|-------|--------------------|--------------------|---------|---------|---------|--------------|------------------|--|---------------------------------------|----------------------------------|
| 1     |       |                    |                    |         |         |         |              |                  |  |                                       |                                  |
| 2     |       |                    |                    |         |         |         |              |                  |  |                                       |                                  |
| 3     |       |                    |                    |         |         |         |              |                  |  |                                       |                                  |
| 4     |       |                    |                    |         |         |         |              |                  |  |                                       |                                  |
| 5     |       |                    |                    |         |         |         |              |                  |  |                                       |                                  |
| 6     |       |                    |                    |         |         |         |              |                  |  |                                       |                                  |
| 7     |       |                    |                    |         |         |         |              |                  |  |                                       |                                  |
| 8     |       |                    |                    |         |         |         |              |                  |  |                                       |                                  |
| 9     |       |                    |                    |         |         |         |              |                  |  |                                       |                                  |
| 10    |       |                    |                    |         |         |         |              |                  |  |                                       |                                  |
| 11    |       |                    |                    |         |         |         |              |                  |  |                                       |                                  |
| 12    |       |                    |                    |         |         |         |              |                  |  |                                       |                                  |
| 13    |       |                    |                    |         |         |         |              |                  |  |                                       |                                  |
| 14    |       |                    |                    |         |         |         |              |                  |  |                                       |                                  |

(“r” is the radius of the brake drum)

### Expected graphs:

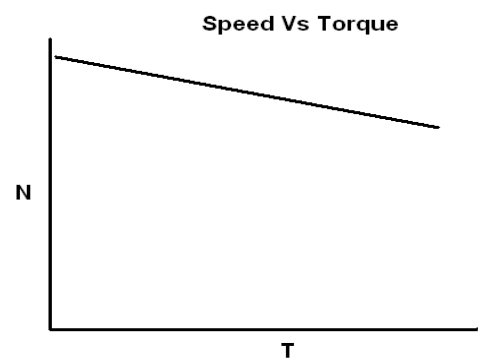
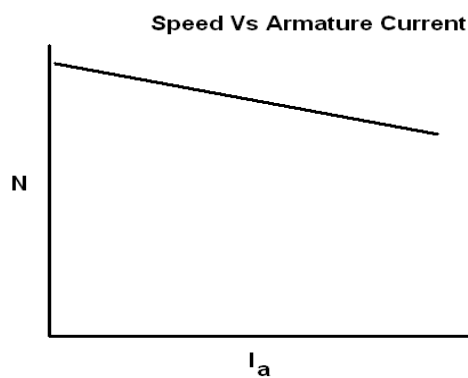
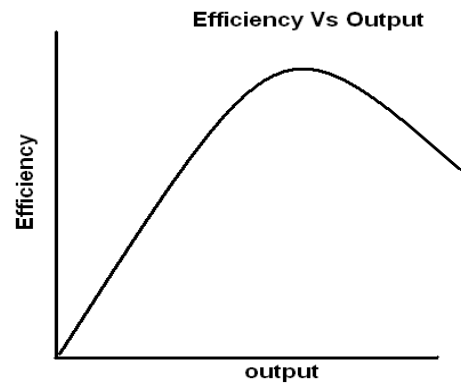
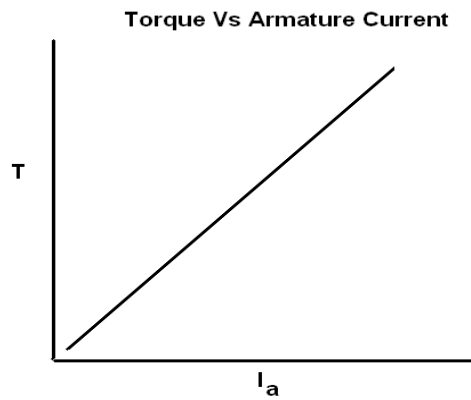

### Sample Calculations:

#### Precautions:

1. Before starting the experiment pour some water into the brake drum and also while doing the experiment.
2. Stay away from the brake drum when switching off the motor.

#### Result:

#### Viva questions:

1. What are the methods for finding the efficiency?
2. What are the basic requirements to conduct the load test?
3. Compare the load characteristics for different types of DC motors.
4. If two motors are required to drive a common load, how will they share the total load?
5. What are the functions of a DC motor Starter?
6. If starter is not available, how can you start a D.C motor?
7. What is the efficiency range of a D.C motor?
8. Where can you use the D.C shunt motor?
9. Why is it considered as a constant speed motor?





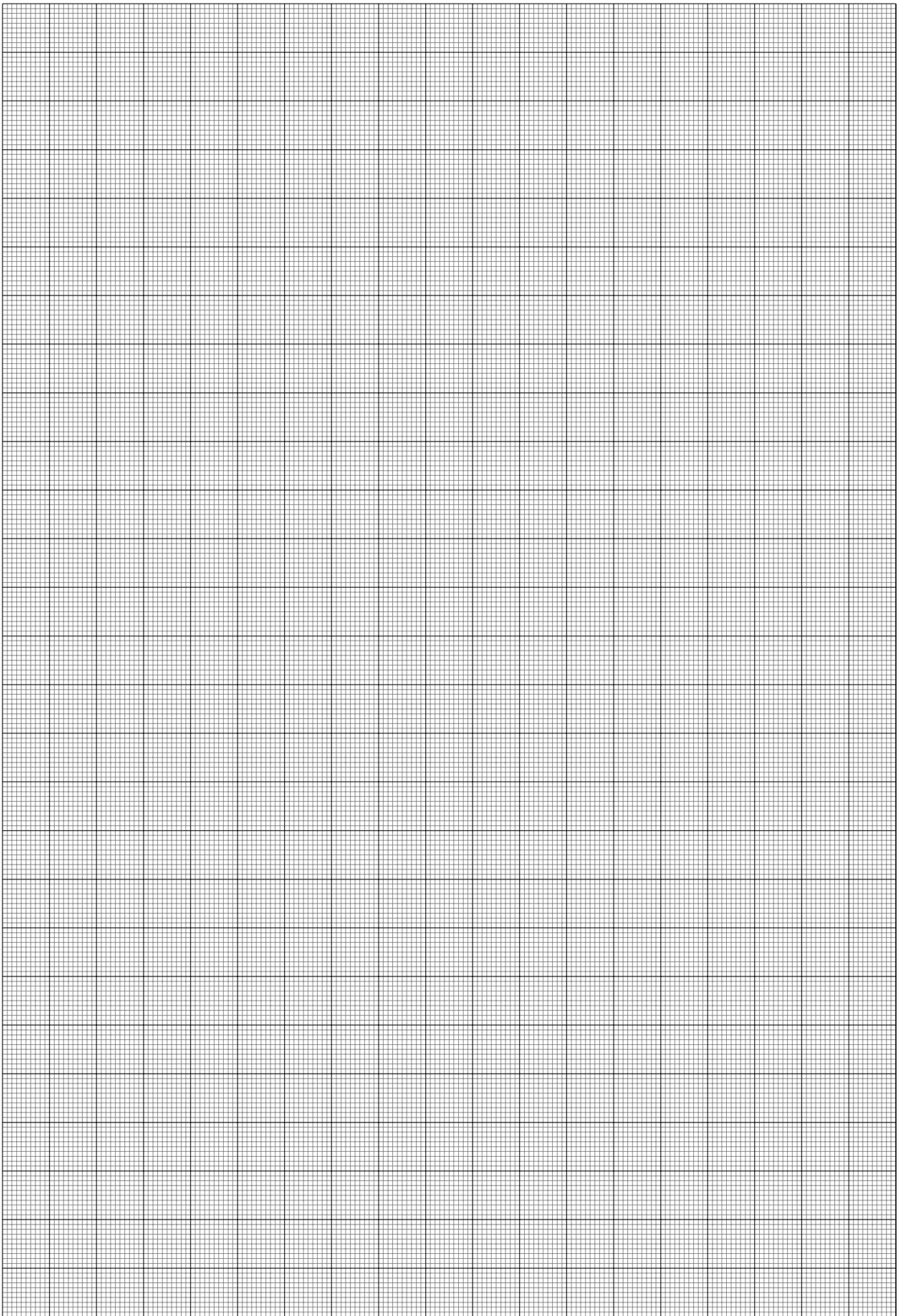

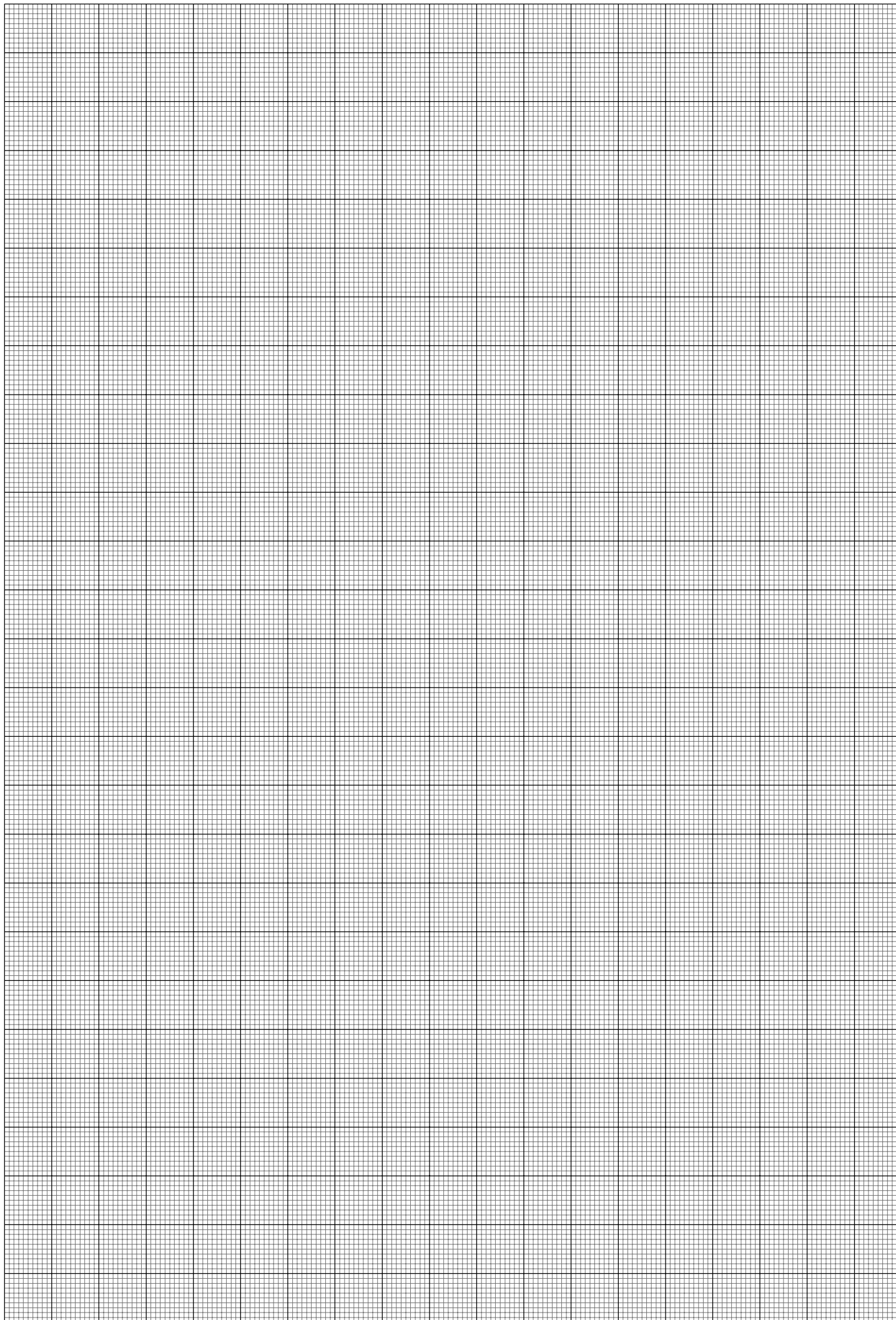

**Expt. No. 7. Measurement of Phase Voltage/Current, Line Voltage/Current and Power in Balanced Three-Phase Circuit Connected in Star and Delta**

**Aim:** To study the balanced three phase system for star & delta connected load.

**Apparatus:**

| S. No | Equipment Name     | Type        | Range/Rating       | Qty. |
|-------|--------------------|-------------|--------------------|------|
| 1     | Three phase Variac |             | 440/0-440V         | 1    |
| 2     | Ammeter            | MI          | 10A                | 1    |
| 3     | Voltmeter          | MI          | 600V               | 1    |
| 4     | R-Load             |             | 1 KW,20 A          | 1    |
| 5     | Wattmeter Meter    | Dynamometer | 0-300V/5A, UPF     | 1    |
| 6     | Connecting wires   |             | As per requirement | ---  |

**Theory:-**

Any three phase system, either supply system or load can be connected in two ways either star or delta.

- 1. Star Connection**→ In this connection, the starting or termination ends of all winding are Connected together & along with their phase ends this common point is also brought out called as neutral point.
- 2. Delta Connection-** If the terminating end of one winding is connected to starting end of other And if connection is continued for all their windings in this fashion we get closed loop. The three supply lines are taken out from three junctions. This is called as three phase delta connected system.

The load can be connected in similar manner. In this experiment we are concerned with balanced load.

Some term related to 3 phase system

**i. Line Voltage** - The voltage between any two lines of 3- phase loads is called as line voltage.

E.g.  $V_{RY}$ ,  $V_{YB}$  &  $V_{BR}$ ... For balance system all are equal in magnitude.

**ii. Line Current** – The current in each line is called as line current.

E.g.  $I_R$ ,  $I_Y$  &  $I_B$  They are equal in magnitude for balance system.

**iii. Phase Voltage** – The voltage across any branch of three phase load is called as phase voltage.

E.g.  $V_{RN}$ ,  $V_{YN}$ , &  $V_{BN}$  are phase voltage.

**iv. Phase Current** – current passing through any phase of load is called as phase current.

**For star connection of load:**

Line voltage ( $V_L$ ) =  $\sqrt{3}$  phase voltage ( $V_{ph}$ ) Line current ( $I_L$ ) = Phase current ( $I_{ph}$ )

**For delta connection of load:**

Line voltage ( $V_L$ ) = phase voltage ( $V_{ph}$ ) Line current ( $I_L$ ) =  $\sqrt{3}$  phase current ( $I_{ph}$ )

Three phase power is given by,

$$P = \text{power consumed by the load} = \sqrt{3} V_L I_L \cos(\Phi)$$

Where  $\Phi$  is phase angle & it depends on type of load i.e. inductive, capacitive or resistive.

**Circuit diagram:**

**Circuit Diagram: A) For star connected load:**

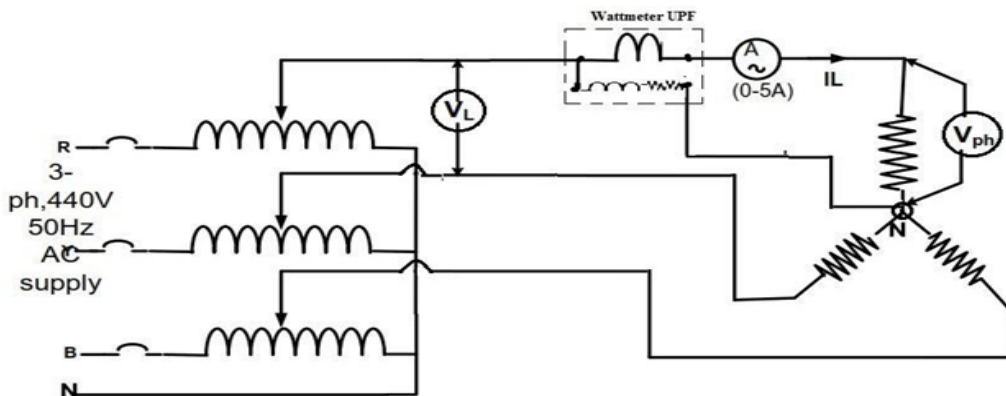

**B) For Delta connected load:**

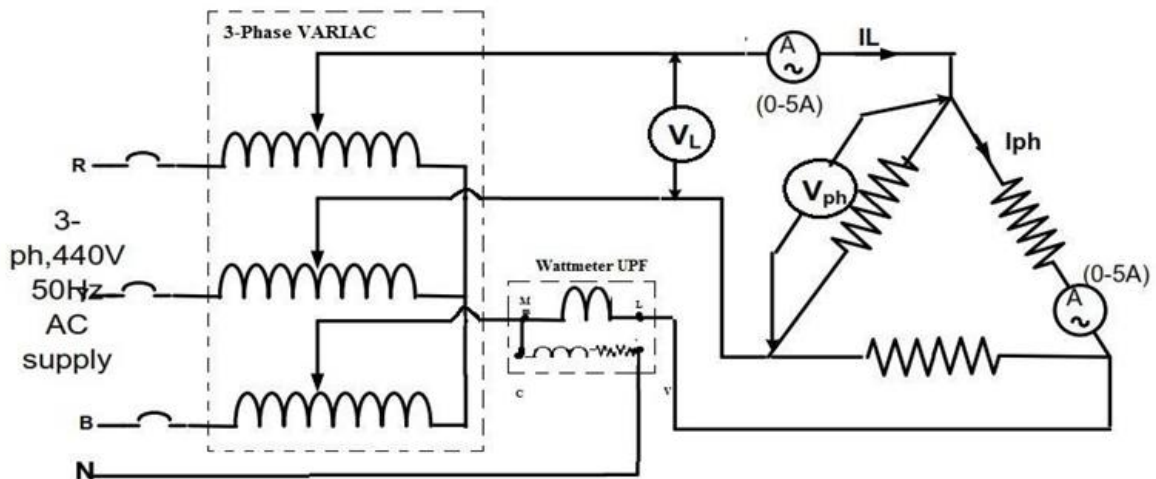

**Procedure:**

1. Connect circuit as shown in the circuit diagram Star.
2. Set 3-phase variac to minimum position.
3. Switch ON the main supply.
4. Apply a voltage by using 3-phvariac.
5. Note the readings of ammeter, voltmeter & wattmeter.
6. Repeat the above procedure by changing connections to Delta Load.

**Tabular Forms:**

| <b><u>For Star Connection:</u></b> |                               |                                 |                                 |  |           |
|------------------------------------|-------------------------------|---------------------------------|---------------------------------|--|-----------|
| S. No                              | Line Voltage(V <sub>L</sub> ) | Phase Voltage(V <sub>Ph</sub> ) | Phase Current(I <sub>Ph</sub> ) | Power<br>$W = \sqrt{3} V_L I_L \cos\phi$ | Wattmeter |
|                                    |                               |                                 |                                 |  |           |
|                                    |                               |                                 |                                 |  |           |
|                                    |                               |                                 |                                 |  |           |

| <b><u>For Delta Connection:</u></b> |                               |                               |                                 |  |           |
|-------------------------------------|-------------------------------|-------------------------------|---------------------------------|--|-----------|
| S. No                               | Line Voltage(V <sub>L</sub> ) | Line Current(I <sub>L</sub> ) | Phase Current(I <sub>Ph</sub> ) | Power<br>$W = \sqrt{3} V_L I_L \cos\phi$ | Wattmeter |
|                                     |                               |                               |                                 |  |           |
|                                     |                               |                               |                                 |  |           |
|                                     |                               |                               |                                 |  |           |

**Result:**

**Viva Questions:**

1. Define power?
2. What are the relationships between voltages and currents in Star & Delta Connected systems?
3. Explain Balance and unbalanced 3-phase systems?
4. Define Voltage?
5. Define Current?



## **Expt. No. 8. V-I Characteristics of silicon and Germanium diodes and measurement of static and dynamic resistances**

**Aim:** To obtain and plot the forward and reverse V-I characteristics of P-N junction diode (Si and Ge) and to determine the static and dynamic resistances.

### **Apparatus:**

| S. No | Equipment Name         | Type        | Range                        | Qty            |
|-------|------------------------|-------------|------------------------------|----------------|
| 1     | Regulated Power Supply | DC          | (0 – 30) V,2A                | 1 No.          |
| 2     | Voltmeters             | Digital(DC) | (0 – 20)V                    | 1 No.          |
| 3     | Ammeters               | Digital(DC) | (0-50) mA<br>(0-100) $\mu$ A | 1 No.<br>1 No. |
| 4     | Si. Diode              | 1N4007      |                              | 1 No.          |
| 5     | Ge. Diode              | OA 79       |                              | 1 No.          |
| 6     | Resistors              |             | 1 K $\Omega$                 | 1 No.          |
| 7     | Bread Board            | ----        | ----                         | 1 No.          |

### **Theory:**

When one half of a piece of semiconductor material is doped with p-type impurity and the other half with n-type impurity, a p-n junction is formed and a potential barrier develops. The terminal brought out from the p-type is the anode and the terminal brought out from the n-type is the cathode. When the anode is connected to the positive terminal of the battery, and cathode to negative terminal, the diode is forward-biased, it's potential barrier lowered and large current flows which is restricted by the introduction of a series resistor. The barrier is merely lowered and does not disappear. When forward biased, the diode resistance will be quite small of the order of tens of ohms. When the polarities are reversed, the diode will be reverse-biased and blocks forward current because the potential barrier is increased and the diode resistance is large of the order of hundreds of kilo-ohms. However, a reverse saturation current of the order of a few micro-amps will flow due to carrier generation. The property of allowing large forward currents and blocking reverse currents (neglecting the reverse saturation current) and the large reverse breakdown voltages (tens to hundreds of volts) makes the device useful as a rectifier that converts AC voltage to pulsating DC voltages.

In a forward bias, the diode conducts when the forward voltage  $V_F$  across the diode exceeds  $V_\gamma$ , the cut-in voltage: The cut-in voltage  $V_\gamma$  is defined as the voltage at which 1% of rated current flows. For example, for the 1N4007 diode the rated current is 1A and therefore the cut-in voltage will be the voltage across the diode when  $1000\text{mA} \times 1/100 = 10\text{mA}$  current flows.

The cut-in voltage for Germanium diode is approximately 0.2 Volts and for Silicon diode is approximately 0.6 Volts.



## Circuit Diagrams:

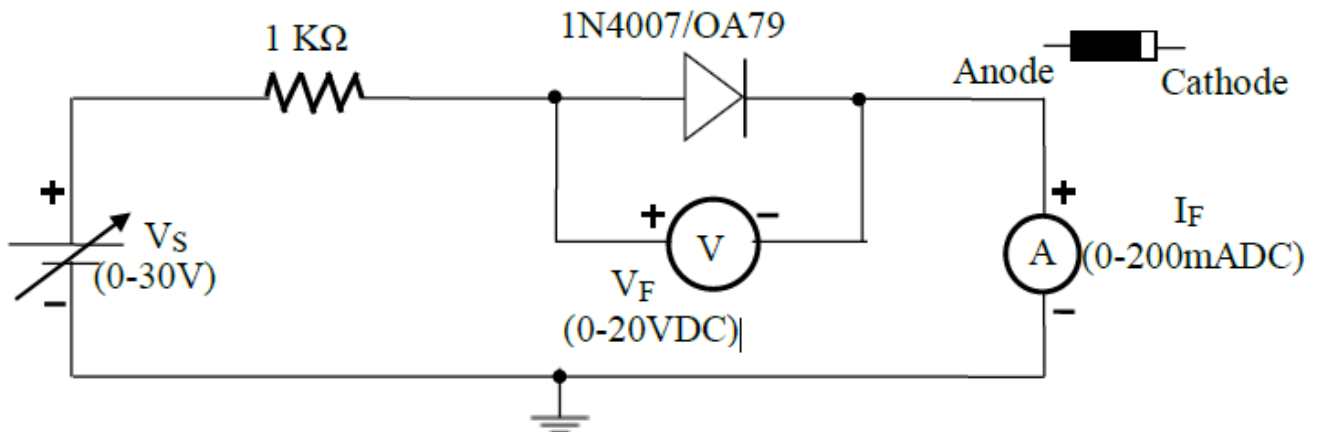

**Fig. 1** Schematic for Forward Bias

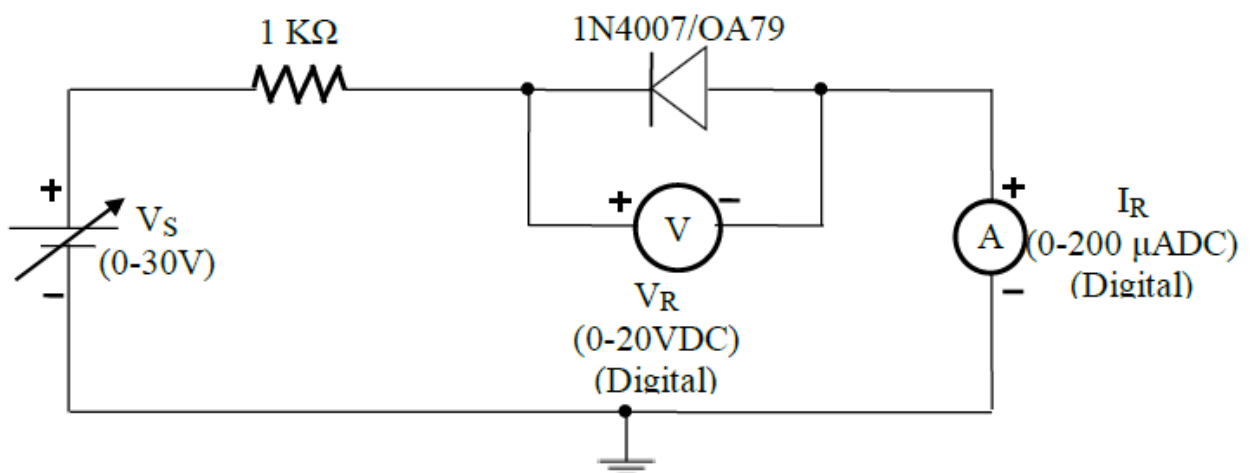

**Fig. 2** Schematic for Reverse Bias

## Procedure:

### Silicon Diode

#### **Forward Bias:**

1. Connect the circuit according to the schematic in Fig. 1. Increase the voltage in steps of 2V up to 8V and then at 16V, 20V, 25V and 30V while noting down in Table 1 the corresponding forward current.
2. Plot the curve of  $V_f$  vs  $I_f$  on a graph paper and calculate the static forward resistance and dynamic forward resistance.

#### **Reverse Bias:**

1. Now connect the circuit according to the schematic in Fig 2. Increase the voltage in steps of 2V up to 8V and then at 16V, 20V, 25V and 30V while noting down the reverse current in Table 2.
2. Plot the curve of  $V_R$  vs  $I_R$  on a graph paper and calculate the static and dynamic Reverse Resistance.

### Germanium Diode

Repeat the above procedure both for forward and reverse bias for Germanium diode.

**Tabular Forms:**

**Forward Bias:**

| <b>Sl. No</b> | <b>Supply Voltage, <math>V_s</math> (Volts)</b> | <b><math>V_F</math> (Volts)</b> | <b><math>I_F</math> (mA)</b> |
|---------------|---|---------------------------------|------------------------------|
|               |   |                                 |                              |
|               |   |                                 |                              |
|               |   |                                 |                              |
|               |   |                                 |                              |
|               |   |                                 |                              |
|               |   |                                 |                              |
|               |   |                                 |                              |
|               |   |                                 |                              |
|               |   |                                 |                              |
|               |   |                                 |                              |
|               |   |                                 |                              |
|               |   |                                 |                              |
|               |   |                                 |                              |
|               |   |                                 |                              |
|               |   |                                 |                              |
|               |   |                                 |                              |
|               |   |                                 |                              |
|               |   |                                 |                              |
|               |   |                                 |                              |
|               |   |                                 |                              |

**Table-1**

**Reverse Bias:**

| <b>Sl. No</b> | <b>Supply Voltage, <math>V_s</math> (Volts)</b> | <b><math>V_R</math> (Volts)</b> | <b><math>I_R</math> (mA)</b> |
|---------------|---|---------------------------------|------------------------------|
|               |   |                                 |                              |
|               |   |                                 |                              |
|               |   |                                 |                              |
|               |   |                                 |                              |
|               |   |                                 |                              |
|               |   |                                 |                              |
|               |   |                                 |                              |
|               |   |                                 |                              |
|               |   |                                 |                              |
|               |   |                                 |                              |
|               |   |                                 |                              |
|               |   |                                 |                              |
|               |   |                                 |                              |
|               |   |                                 |                              |
|               |   |                                 |                              |
|               |   |                                 |                              |
|               |   |                                 |                              |
|               |   |                                 |                              |
|               |   |                                 |                              |
|               |   |                                 |                              |
|               |   |                                 |                              |

**Table-2**

**Model Graphs:**

**MODEL GRAPH:**

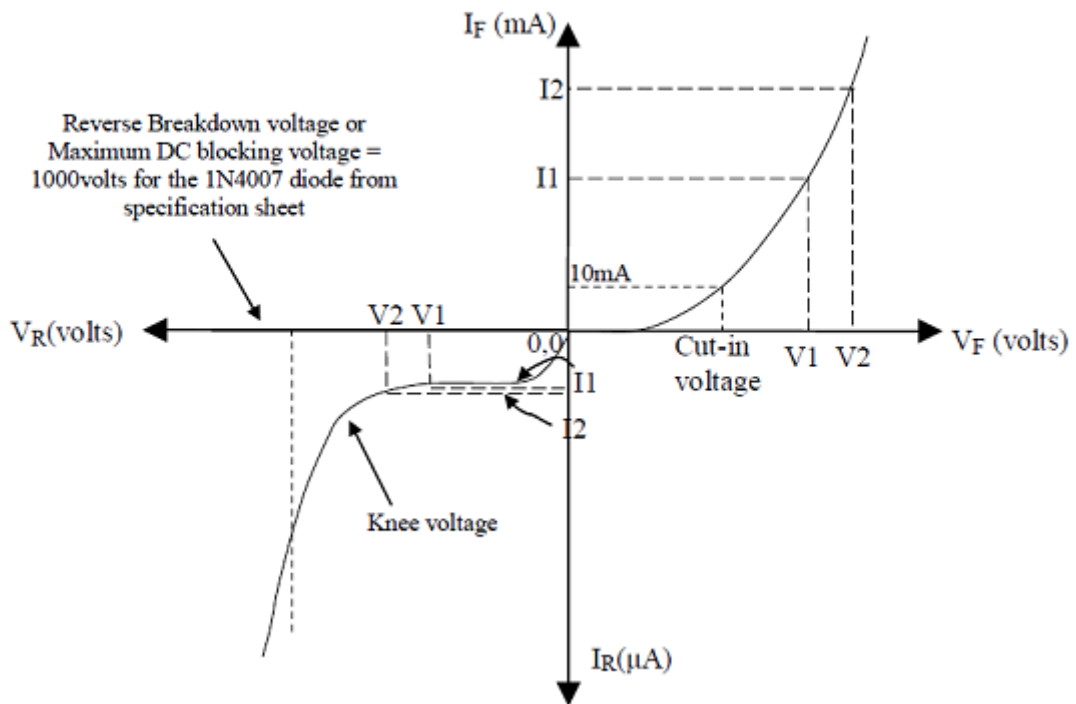

**Calculations:**

**Forward Bias**

Static Resistance =  $V_F/I_F$   
 Dynamic Resistance =  $\Delta V/\Delta I$   
 =  $V_2-V_1/ I_2-I_1$

**Reverse Bias**

Static Resistance =  $V_R/I_R$   
 Dynamic Resistance =  $\Delta V/\Delta I$   
 =  $|V_2|-|V_1|/ |I_2|-|I_1|$

**Result:**

The V-I characteristics of the given p-n junction diode in forward bias and reverse are determined.

1. Cut-in voltage of a PN junction diode 1N4007 is = .....volts =.....mA.  
 OA79 is = .....volts =.....mA
2. Static Forward Resistance 1N4007 is = .....Volts is = ..... $\Omega$   
 OA79 is = .....Volts is = ..... $\Omega$
3. Dynamic Forward Resistance 1N4007 is = .....Volts is = ..... $\Omega$   
 OA79 is = .....Volts is = ..... $\Omega$
4. Static Reverse Resistance 1N4007 is = .....Volts is = ..... $\Omega$   
 OA79 is = .....Volts is = ..... $\Omega$
5. Dynamic Reverse Resistance 1N4007 is = .....Volts is = ..... $\Omega$   
 OA79 is = .....Volts is = ..... $\Omega$

### **Viva Questions:**

1. What is the main function or purpose of a p-n junction diode? How is it different from a piece of wire or a conductor of say, copper, silver or gold?
2. Is the P-N junction diode a passive element or an active element?
3. What is the importance of the type number given to the various diodes?
4. What is meant by potential barrier across a P-N junction?
5. What is the significance of a diode as a device?
6. What is cut-in voltage? What is the value of cut-in voltage for Ge and Si diodes? What is the reason for the difference in cut-in voltage of Ge. and Si.
7. Explain physically how a P-N junction functions as a rectifier.
8. What is the expression for the total current in a P-N junction? How does it vary with the applied voltage?
9. What do you understand by a reverse saturation current? What are the typical values?
10. Why is the magnitude of the current in the forward biased diode greater than that in the reverse biased Diode?
11. How does the reverse saturation current vary with temperature for Ge. and Si diodes? Is it of Significance? While the circuit designer chooses a particular device in design?
12. What do you understand by dynamic and static resistance? How are these values obtained graphically?
13. Define the terms forward and reverse resistance of a P-N Junction diode.
14. Explain the capacitive effects in a junction.



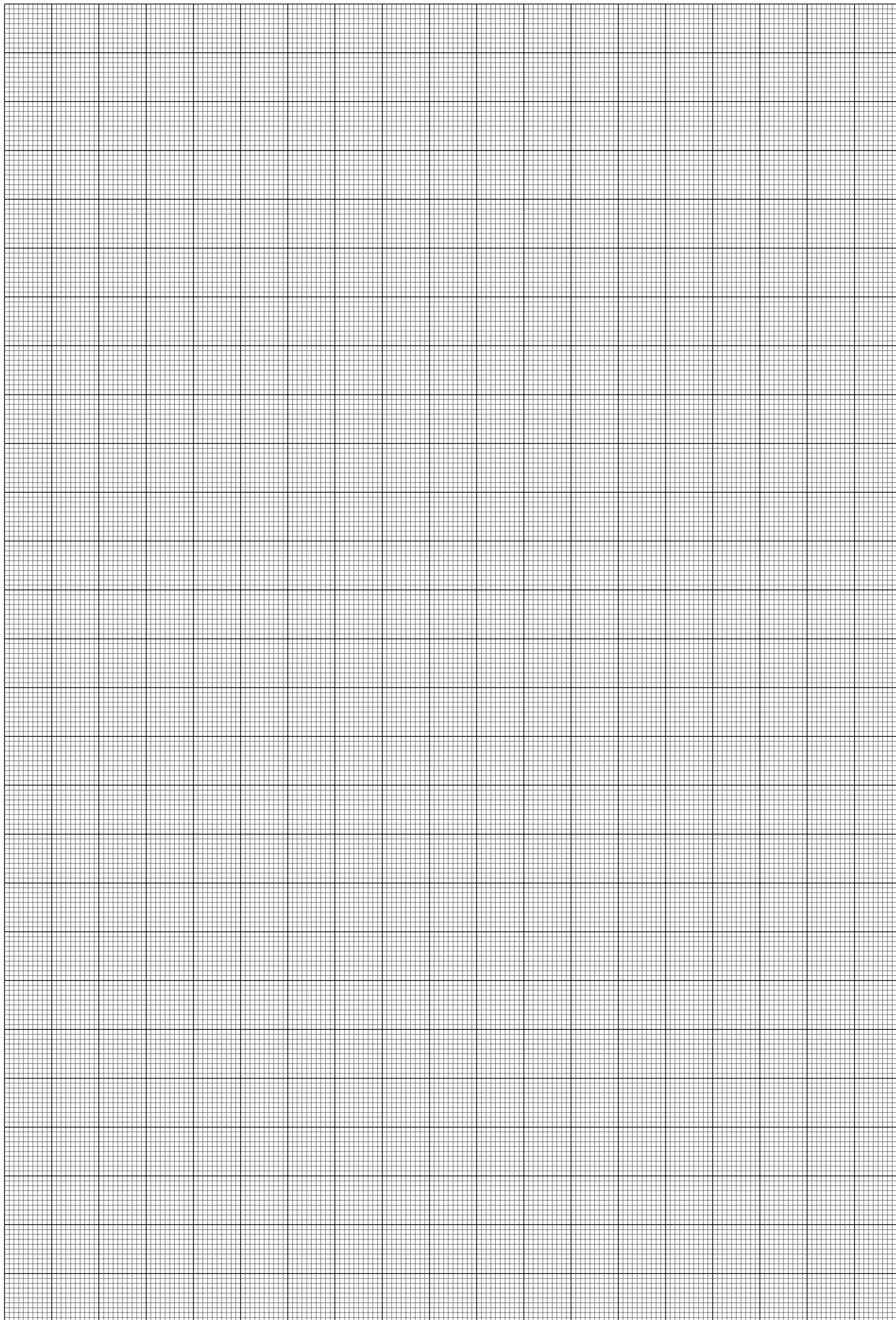

## Expt. No. 9. V-I Characteristics of silicon and Germanium diodes of Zener diode and measurement of static and dynamic resistances

**Aim:** To obtain and plot the V-I characteristics of a Zener diode and determine its static and dynamic Resistances.

### **Apparatus:**

| S. No | Equipment Name               | Type           | Range                   | Qty.           |
|-------|------------------------------|----------------|-------------------------|----------------|
| 1     | Regulated Power Supply       | DC             | (0 – 30) V,2A           | 1 No.          |
| 2     | Voltmeters                   | Digital(DC)    | (0 – 20)V               | 2 No.          |
| 3     | Ammeters                     | Digital(DC)    | (0-50) mA<br>(0-100) mA | 1 No.<br>1 No. |
| 4     | Diode<br>(Zener, 5V nominal) | BZX79-<br>C5V1 |                         | 1 No.          |
| 5     | Decade Resistance Box        |                | 1Ω - 10 MΩ              | 1 No.          |
| 6     | Resistors                    |                | 2.2 KΩ                  | 2 No.          |
| 7     | Bread Board                  | ----           | ----                    | 1 No.          |

### **Theory:**

A zener diode is a special kind of diode which not only allows current when forward biased like an ideal diode but will also allow it to flow in the reverse direction when the voltage is above a certain voltage known as the breakdown voltage or the zener voltage. The Zener diode's operation depends on the heavy doping of its p-n junction allowing electrons to tunnel from the valence band of the p-type material to the conduction band of the n-type material. When reverse-biased and when the electric field at the junction is approximately  $2 \times 10^7$  Volts per meter, a sufficiently strong force may be exerted by the electric field directly on a bound electron to tear it out of its covalent bond. The new hole-electron pair which is created increases the reverse current, and the process is called **Zener breakdown**. In Zener diodes a very thin depletion layer is made possible due to heavy doping. In Zener diodes of voltages less than 6 volts, the Zener breakdown mechanism is predominant, while for diodes above 6 volts, breakdown occurs due to avalanche mechanism.

In lightly doped diodes, the depletion layer will be broader and the **avalanche process** occurs when the thermally generated electrons and holes acquire sufficient energy from the applied potential (electric field) to produce new carriers (free electrons) by removing valence electrons from their bonds. The freed electrons in turn gain sufficient energy to collide with atoms in the transition region and detach valence electrons from their bonds resulting in avalanche multiplication and increasing reverse current levels. The avalanche process can be made to occur with smaller reverse bias voltages by increasing the doping levels. All such diodes irrespective of the breakdown mechanism are available as Zener diodes, commercially and may be employed as voltage references or constant-voltage devices.

## Circuit Diagrams:

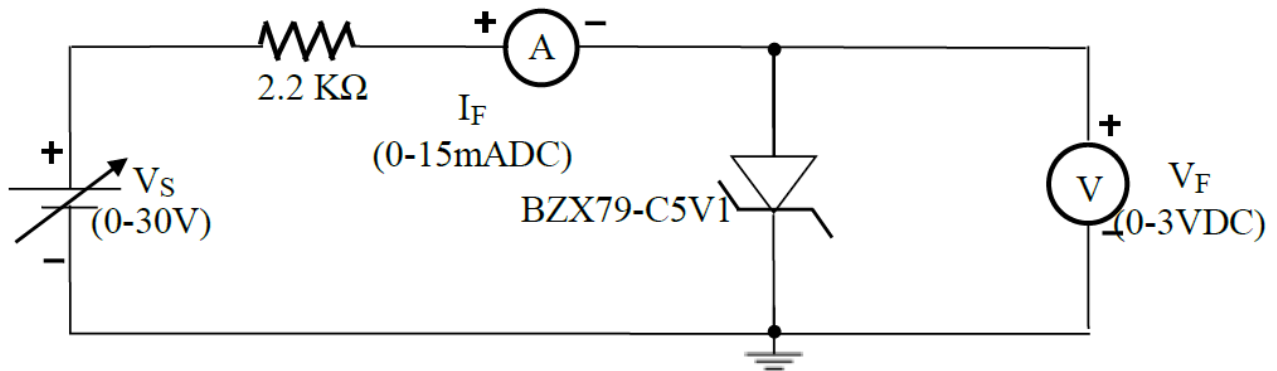

**Fig. 1** Schematic for forward bias

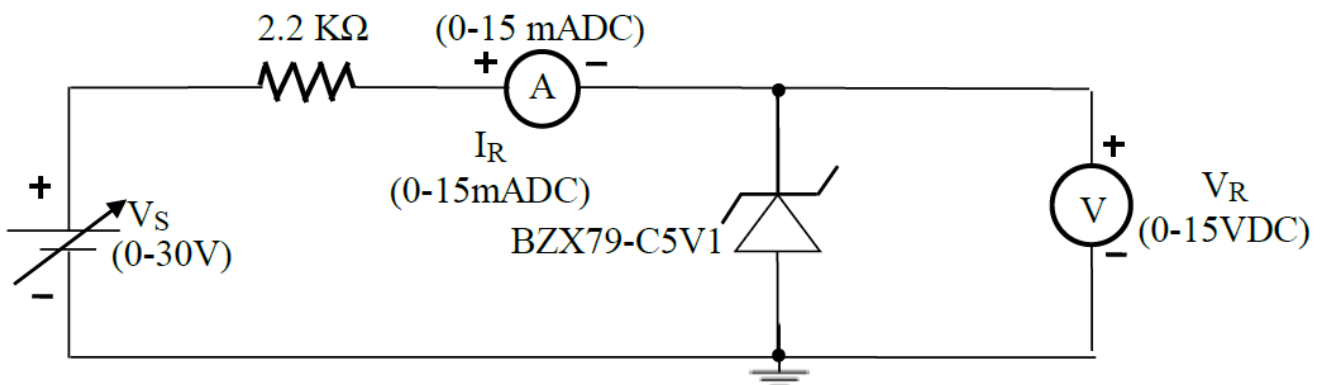

**Fig. 2** Schematic for reverse bias

## Procedure:

### **Forward Bias:**

1. Connect the circuit according to the schematic in Fig 1. Increase the voltage in steps of 2 volts up to 8V and then at 16V, 20V, 25V and 30V while noting down in Table 1 the corresponding forward current.
2. Plot the curve of  $V_F$  vs  $I_F$  on a graph paper and calculate the static forward resistance and dynamic forward resistance.

### **Reverse Bias:**

1. Now connect the circuit according to the schematic in Fig 2. Increase the voltage in steps of 2V up to 12V and then at 16V while noting down the reverse current in Table 2.
2. Plot the curve of  $V_R$  vs.  $I_R$  on a graph paper and calculate the static reverse resistance and dynamic reverse resistance.
3. From the plot of  $V_R$  vs  $I_R$ , verify that the breakdown voltage @5mA of the given Zener diode is within the range specified in the specification sheet.



**Tabular Forms:**

**Forward Bias:**

| <b>Sl. No</b> | <b>Supply Voltage, <math>V_S</math> (Volts)</b> | <b><math>V_F</math> (Volts)</b> | <b><math>I_F</math> (mA)</b> |
|---------------|---|---------------------------------|------------------------------|
|               |   |                                 |                              |
|               |   |                                 |                              |
|               |   |                                 |                              |
|               |   |                                 |                              |
|               |   |                                 |                              |
|               |   |                                 |                              |
|               |   |                                 |                              |
|               |   |                                 |                              |
|               |   |                                 |                              |
|               |   |                                 |                              |
|               |   |                                 |                              |
|               |   |                                 |                              |
|               |   |                                 |                              |
|               |   |                                 |                              |
|               |   |                                 |                              |
|               |   |                                 |                              |
|               |   |                                 |                              |
|               |   |                                 |                              |
|               |   |                                 |                              |
|               |   |                                 |                              |

**Table-1**

**Reverse Bias:**

| <b>Sl. No</b> | <b>Supply Voltage, <math>V_S</math> (Volts)</b> | <b><math>V_R</math> (Volts)</b> | <b><math>I_R</math> (mA)</b> |
|---------------|---|---------------------------------|------------------------------|
|               |   |                                 |                              |
|               |   |                                 |                              |
|               |   |                                 |                              |
|               |   |                                 |                              |
|               |   |                                 |                              |
|               |   |                                 |                              |
|               |   |                                 |                              |
|               |   |                                 |                              |
|               |   |                                 |                              |
|               |   |                                 |                              |
|               |   |                                 |                              |
|               |   |                                 |                              |
|               |   |                                 |                              |
|               |   |                                 |                              |
|               |   |                                 |                              |
|               |   |                                 |                              |
|               |   |                                 |                              |
|               |   |                                 |                              |
|               |   |                                 |                              |
|               |   |                                 |                              |
|               |   |                                 |                              |

**Table-2**

**Model Graphs:**

**MODEL GRAPH:**

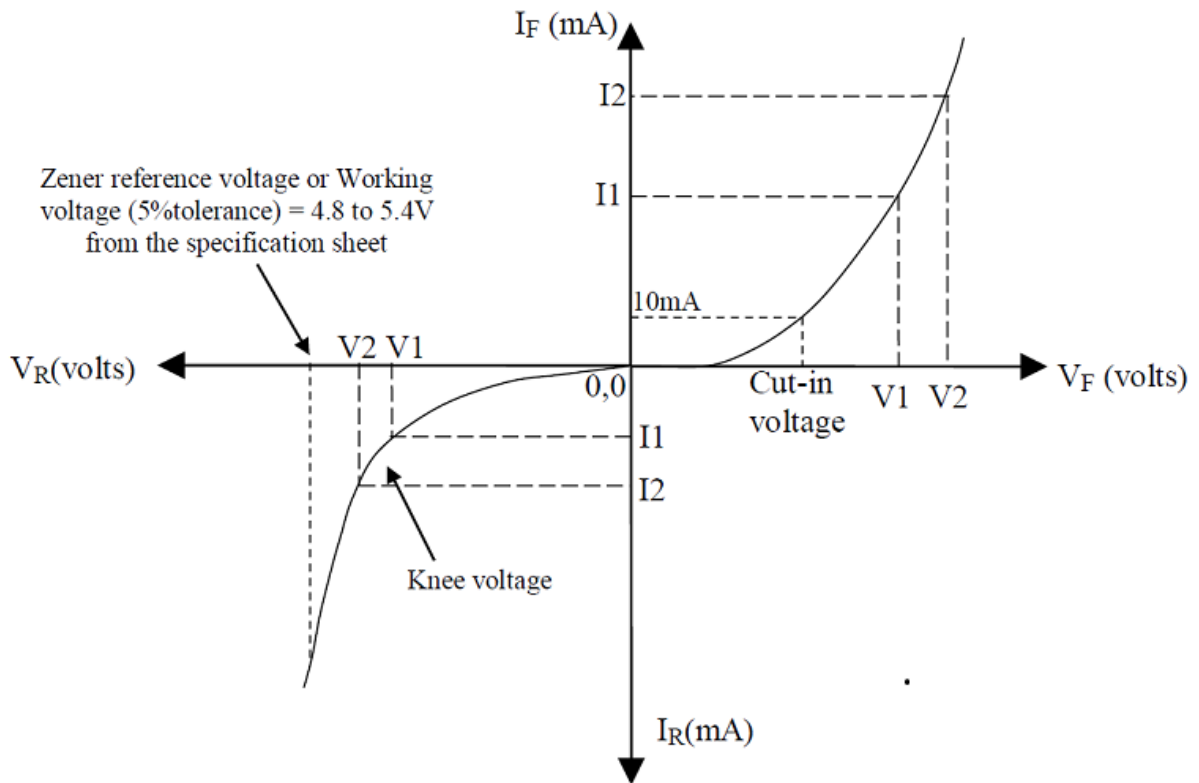

**Calculations:**

**Forward Bias**

$$\text{Static Resistance} = V_F / I_F$$

$$\text{Dynamic Resistance} = \Delta V / \Delta I = V_2 - V_1 / I_2 - I_1$$

**Reverse Bias**

$$\text{Static Resistance} = V_R / I_R$$

$$\text{Dynamic Resistance} = \Delta V / \Delta I = |V_2 - V_1| / |I_2 - I_1|$$

**Result:**

The V-I characteristics of a Zener diode in forward bias and reverse bias are determined.

1. Static Forward Resistance = .....Volts is = ..... $\Omega$
2. Dynamic Forward Resistance = ....volts is = ..... $\Omega$
3. Static Reverse Resistance = ....volts is = ..... $\Omega$
4. Dynamic Reverse Resistance = ....volts is = ..... $\Omega$
5. The breakdown voltage of the given zener diode is = .....volts and this is within the Range .....to .....volts specified in the specification sheet.

**Viva Questions:**

1. What are the typical applications of a Zener diode?
2. Why is a Zener diode generally not connected in forward bias?
3. What is meant by regulation? Why is it required?
4. Define the various types of breakdown possible in diodes.
5. Give the typical application of an avalanche breakdown diode.
6. How do we test a diode using a multimeter?



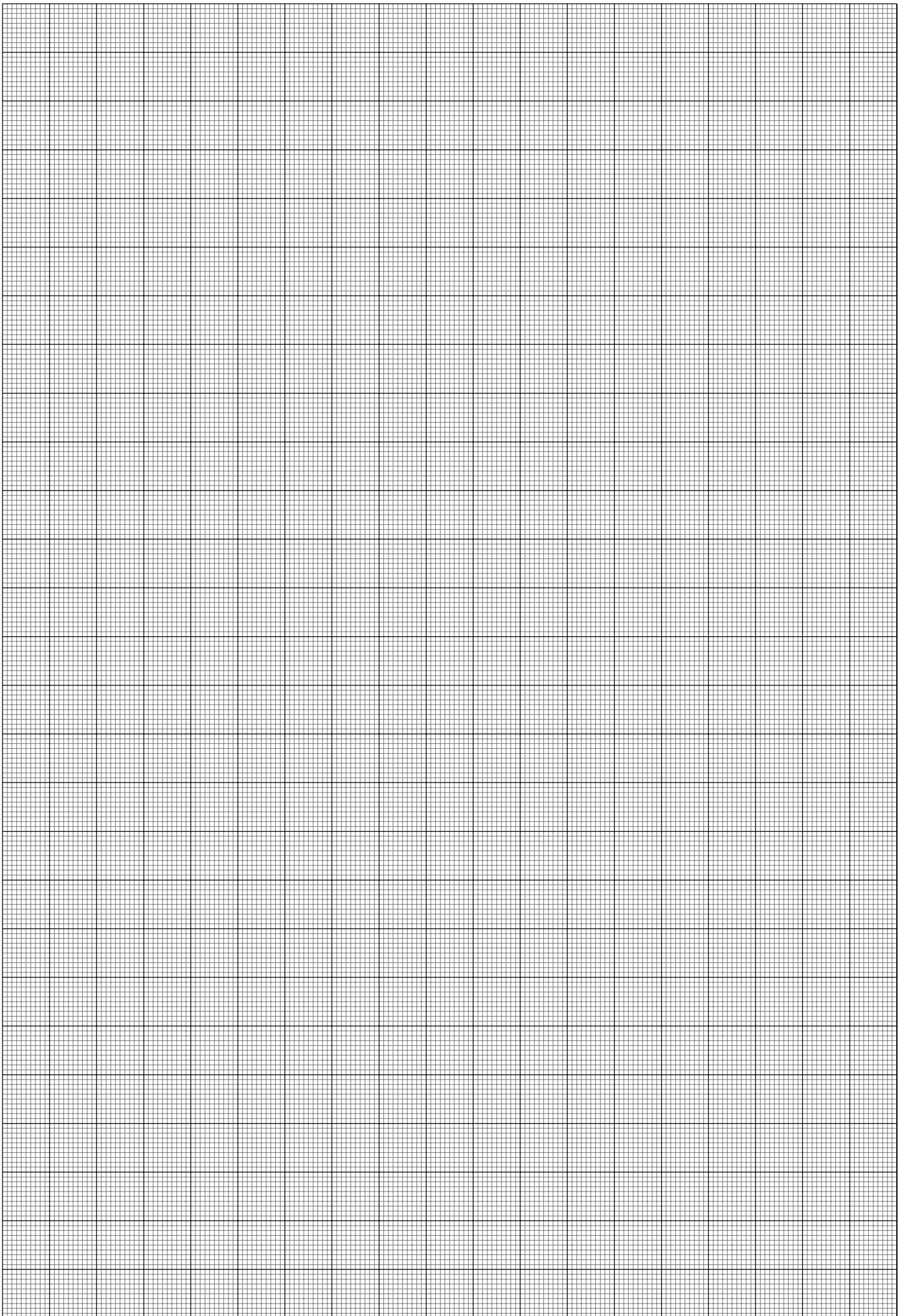

## Expt.No.10. Input and output Characteristics of BJT in Common Base configuration

**Aim:** To plot the input and output characteristics of a transistor in CB Configuration and to compute the  $h$  – Parameters.

### Apparatus:

| S. No | Equipment Name         | Type        | Range               | Qty.  |
|-------|------------------------|-------------|---------------------|-------|
| 1     | Regulated Power Supply | DC          | (0 – 30) V, 2A      | 2 No. |
| 2     | Voltmeters             | Digital(DC) | (0 – 2)V, (0 – 20)V | 1 No. |
| 3     | Ammeters               | Digital(DC) | (0-100) mA          | 2 No. |
| 4     | Transistor             | BC107       |                     | 1 No. |
| 5     | Resistors              |             | 1 K $\Omega$        | 2 No. |
| 6     | Bread Board            | ----        | ----                | 1 No. |

### Theory:

Bipolar junction transistor (BJT) is a 3 terminal (emitter, base, collector) semiconductor device. There are two types of transistors namely NPN and PNP. It consists of two P-N junctions namely emitter junction and collector junction.

In Common Base configuration the input is applied between emitter and base and the output is taken from collector and base. Here base is common to both input and output and hence the name common base configuration.

Input characteristics are obtained between the input current and input voltage taking output voltage as parameter. It is plotted between  $V_{EB}$  and  $I_E$  at constant  $V_{CB}$  in CB configuration.

Output characteristics are obtained between the output voltage and output current taking input current as parameter. It is plotted between  $V_{CB}$  and  $I_C$  at constant  $I_E$  in CB configuration

A transistor can be in any of the three configurations viz, Common base, Common emitter and Common Collector.

### **PIN Assignment:**

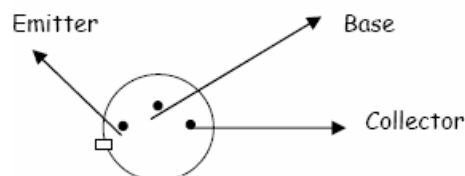

The relation between  $\beta$ ,  $\gamma$  of CB, CE, CC are

In CE configuration base will be input node and collector will be the output node. Here emitter of the transistor is common to both input and output and hence the name common emitter configuration.

The collector current is given as

Where  $I_{C0}$  is called as reverse saturation current

A transistor in CE configuration is used widely as an amplifier. While plotting the characteristics of a transistor the input voltage and output current are expressed as a function of input current and output voltage.

$$\text{i.e., } V_{BE} = f(I_B, V_{CE}) \text{ and}$$

$$I_C = f(I_B, V_{CE})$$

Transistor characteristics are of two types.

Input characteristics:- Input characteristics are obtained between the input current and input voltage at constant output voltage. It is plotted between  $V_{BE}$  and  $I_B$  at constant  $V_{CE}$  in CE configuration

Output characteristics:- Output characteristics are obtained between the output voltage and output current at constant input current. It is plotted between  $V_{CE}$  and  $I_C$  at constant  $I_B$  in CE configuration.

### Circuit Diagrams:

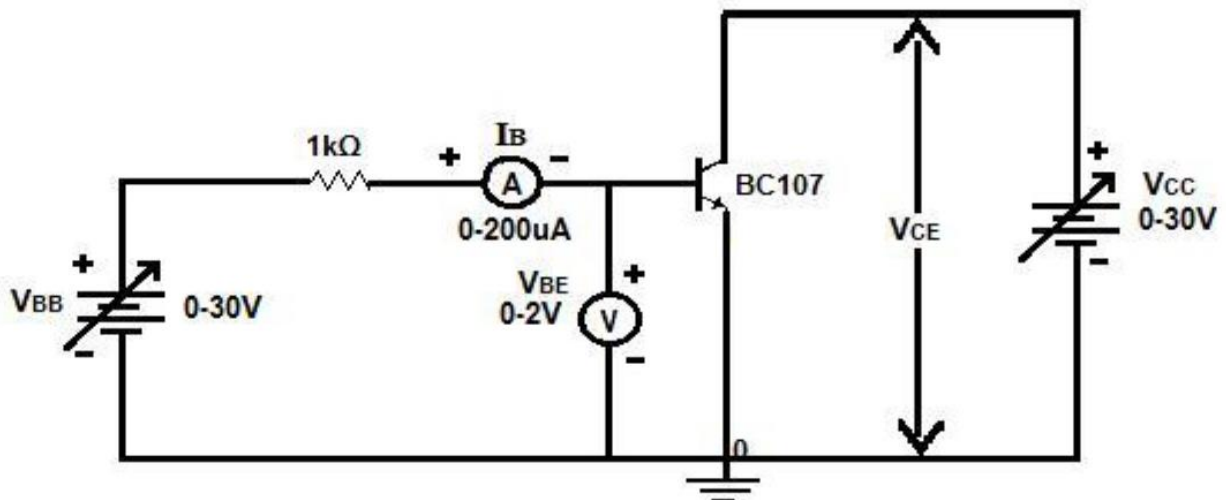

Fig. 1: Input Characteristics

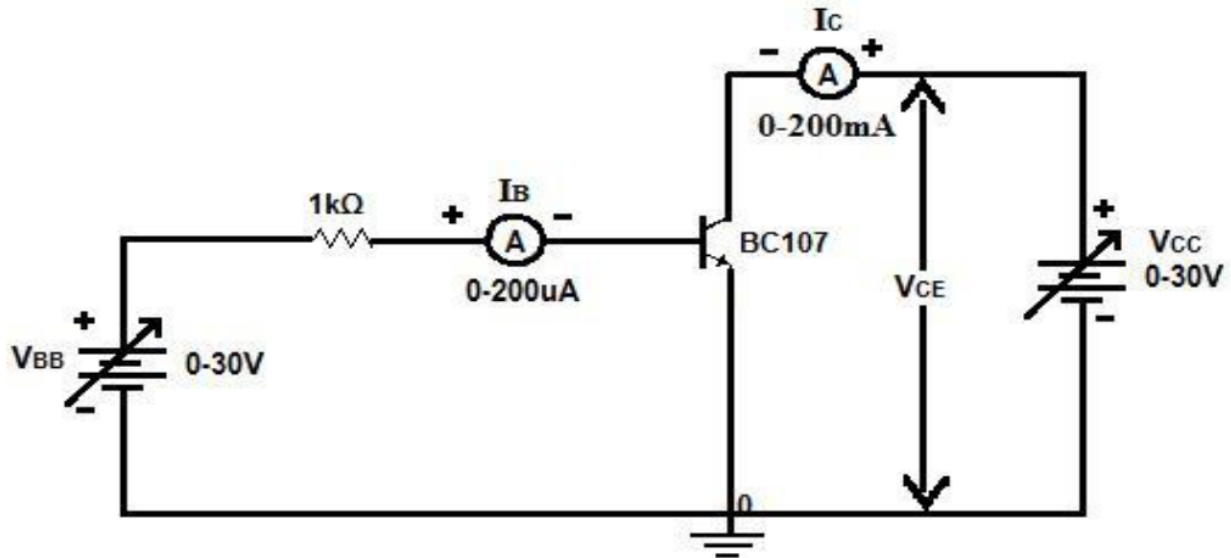

Fig. 2: Output Characteristics

### Procedure:

#### **Input Characteristics:**

- 1) Connect the circuit as shown in fig. (1). Adjust all the knobs of the power supply to their minimum positions before switching the supply on.
- 2) Adjust the  $V_{CE}$  to 0 V by adjusting the supply  $V_{CC}$ .
- 3) Vary the supply voltage  $V_{BB}$  so that  $V_{BE}$  varies in steps of 0.1 V from 0 to 0.5 V and then in steps of 0.02 V from 0.5 to 0.7 V. In each step note the value of base current  $I_B$ .
- 4) Adjust  $V_{CE}$  to 1, 2V and repeat step-3 for each value of  $V_{CE}$ .
- 5) Plot a graph between  $V_{BE}$  and  $I_B$  for different values of  $V_{CE}$ . These curves are called input characteristics.

#### **Output Characteristics:**

- 1) Connect the circuit as shown in fig. (2). All the knobs of the power supply must be at the minimum position before the supply is switched on.
- 2) Adjust the base current  $I_B$  to 20  $\mu\text{A}$  by adjusting the supply  $V_{BB}$ .
- 3) Vary the supply voltage  $V_{CC}$  so that the voltage  $V_{CE}$  varies in steps of 0.2 V from 0 to 2 V and then in steps of 1 V from 2 to 10 V. In each step the base current should be adjusted to the present value and the collector current  $I_C$  should be recorded.
- 4) Adjust the base current at 40, 60  $\mu\text{A}$  and repeat step-3 for each value of  $I_B$ .

Plot a graph between the output voltage  $V_{CE}$  and output current  $I_C$  for different values of the input current  $I_B$ . These curves are called the output characteristics.



**Tabular Forms:**

**Input Characteristics:**

| Sl. No | VCE=0V |              | VCE=2V |              |
|--------|--------|--------------|--------|--------------|
|        | VBE(V) | IB( $\mu$ A) | VBE(V) | IB( $\mu$ A) |
|        |        |              |        |              |
|        |        |              |        |              |
|        |        |              |        |              |
|        |        |              |        |              |
|        |        |              |        |              |
|        |        |              |        |              |
|        |        |              |        |              |
|        |        |              |        |              |

**Table-1**

**Output Characteristics:**

| Sl. No | IB = 20 $\mu$ A |        | IB = 40 $\mu$ A |        | IB = 60 $\mu$ A |        |
|--------|-----------------|--------|-----------------|--------|-----------------|--------|
|        | VCE(V)          | IC(mA) | VCE(V)          | IC(mA) | VCE(V)          | IC(mA) |
|        |                 |        |                 |        |                 |        |
|        |                 |        |                 |        |                 |        |
|        |                 |        |                 |        |                 |        |
|        |                 |        |                 |        |                 |        |
|        |                 |        |                 |        |                 |        |
|        |                 |        |                 |        |                 |        |
|        |                 |        |                 |        |                 |        |
|        |                 |        |                 |        |                 |        |

**Table-2**

### Model Graphs:

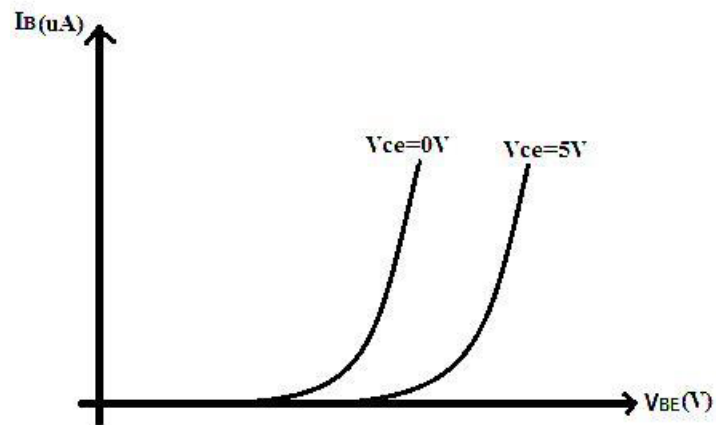

Fig. 3: Input Characteristics

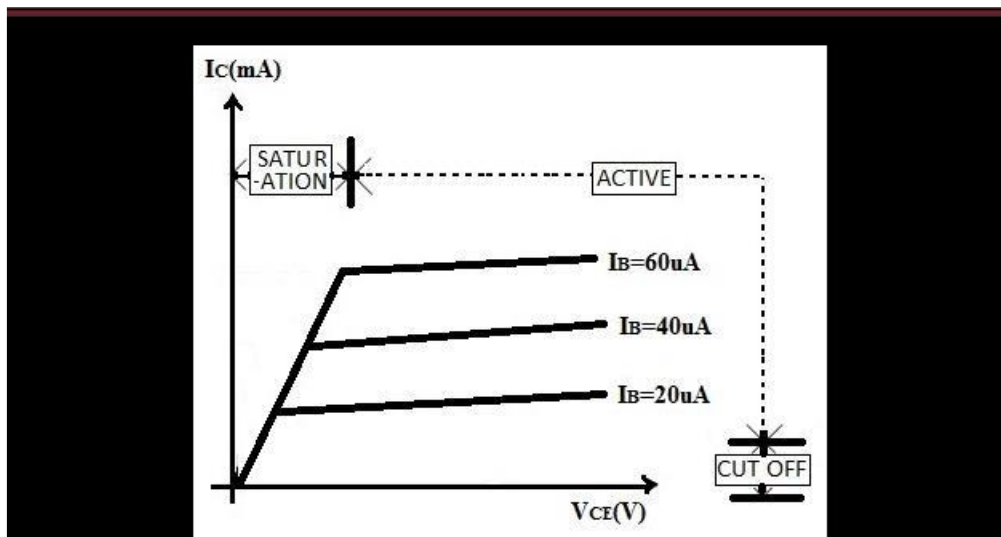

Fig. 4: Output Characteristics

### Result:

Thus the input and output characteristics of CB configuration are plotted and h parameters are found.

- Input impedance ( $h_{ib}$ ) =
- Forward current gain ( $h_{fb}$ ) =
- Output admittance ( $h_{ob}$ ) =
- Reverse voltage gain ( $h_{rb}$ ) =

**Viva Questions:**

1. What is Early effect?
2. Draw the small signal model of BJT Common Base Configuration.
3. What is Reach –Through effect?
4. What are the applications of Common Base?
5. What will be the parameters of CB?
6. Explain the Transistor operation?



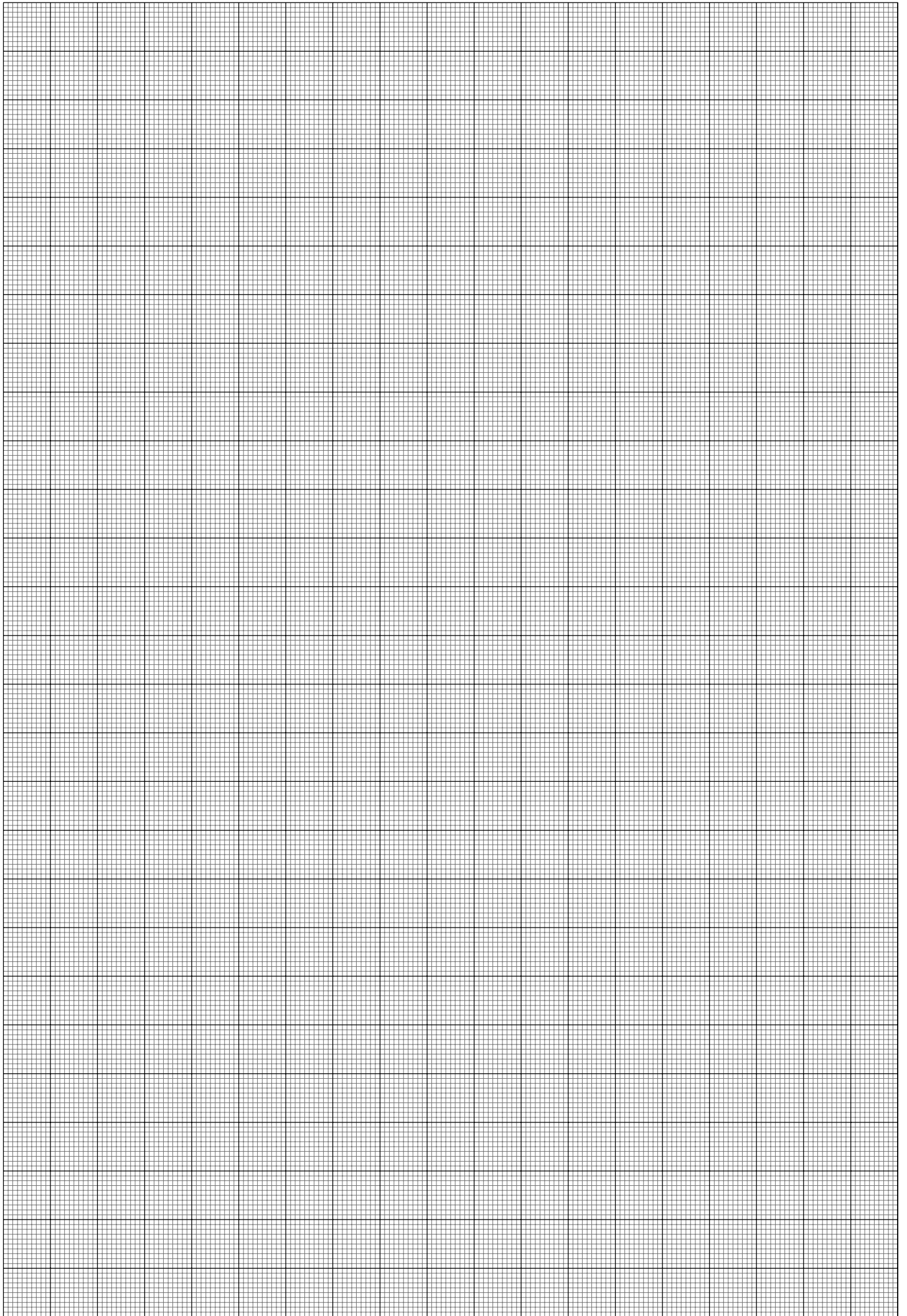

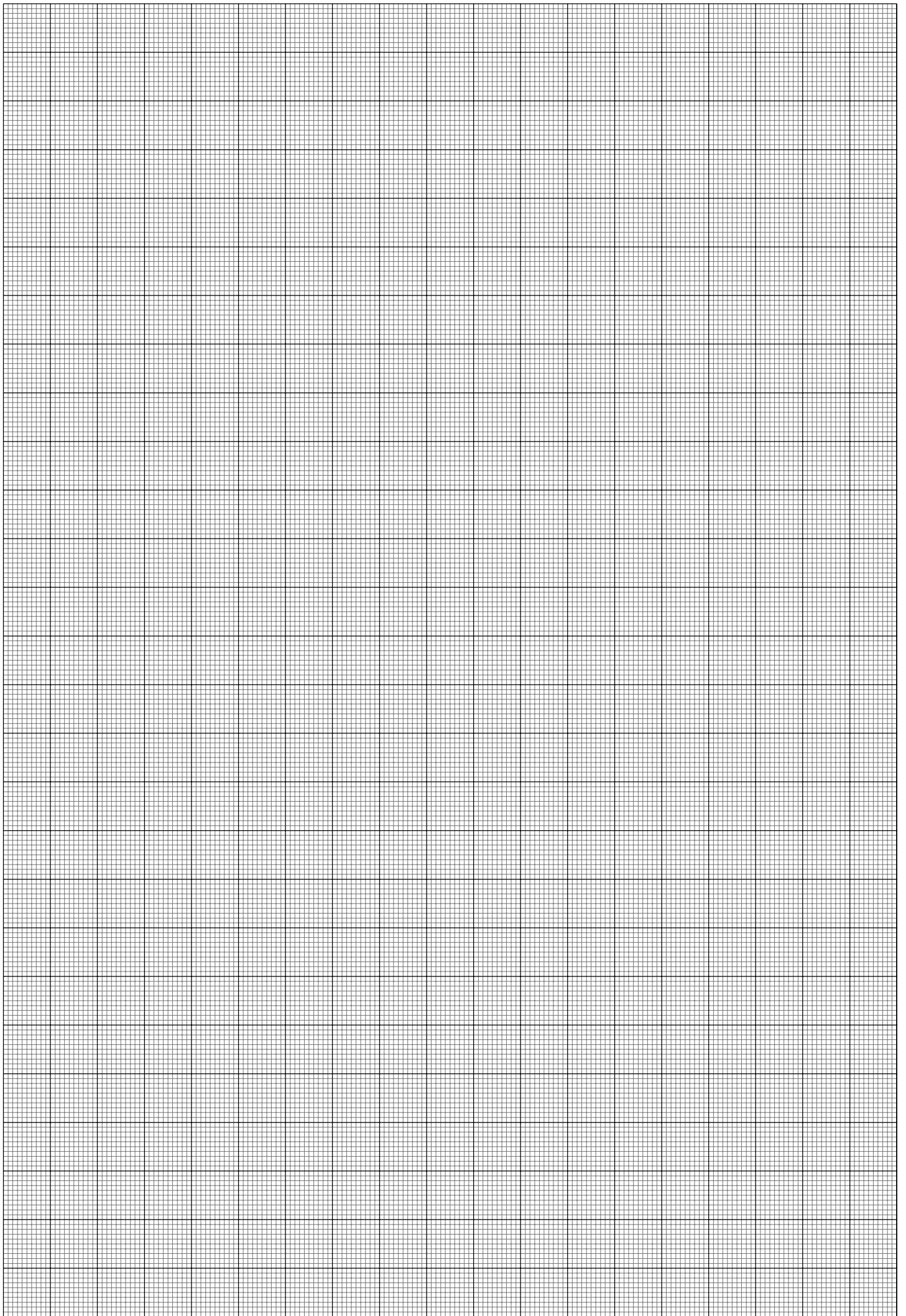

## Expt. No. 11. Swinburne's test

**Aim:** To Pre - determines the efficiency of a DC shunt machine by using Swinburne's test.

### **Name Plate Details:**

| S. No | Parameter | Motor |
|-------|-----------|-------|
|       |           |       |
|       |           |       |
|       |           |       |
|       |           |       |

### **Apparatus:**

| S. No | Equipment Name | Type    | Range          | Qty   |
|-------|----------------|---------|----------------|-------|
| 1     | Voltmeter      | MC      | (0 – 300) V    | 1 No. |
| 2     | Ammeter        | MC      | (0 – 20)A      | 1 No. |
| 3     | Ammeter        | MC      | (0 – 2)A       | 1 No. |
| 4     | Tachometer     | Digital | (0-2000) r.p.m | 1 No. |

### **Theory:**

It is a simple method in which losses are measured separately and from their knowledge, efficiency at any desired load can be predetermined in advance. The only running test needed is no-load test. However, this test is applicable to those machines in which flux is practically constant i.e., shunt and compound – wound machines. The machine is run as a motor on no-load at its rated voltage i.e., voltage stamped on the nameplate. The speed is adjusted with the help of shunt regulation as shown in fig.

The no-load current  $I_0$  is measured by the armature A1 where shunt field current  $I_{sh}$  is given by ammeter A2. The no-load armature current is  $(I_0 - I_{sh})$  or  $I_{a0}$ .

Let, supply voltage =  $V$  no-load input =  $V I_0$  watt

Power input to armature =  $V (I_0 - I_{sh})$ ; Power input to shunt =  $V I_{sh}$

No-load power input to armature supplies the following:-

(i) Iron losses in core

(ii) Friction loss

(iii) Winding loss and

(iv) Armature  $Cu$  loss =  $(I_0 - I_{sh})^2 R_a$  or  $I_{a0}^2 R_a$

If we subtract from the total input the no-load armature  $Cu$  loss, then we get constant losses.

Constant losses  $W_c = V I_0 - (I_0 - I_{sh})^2 R_a$

Knowing the constant losses of the machine, its efficiency at any other load can be determined as given below.

Advantages: -

1. Since constant losses are known, the efficiency can be estimated at any load.
2. The method is convenient and economical as less power is required.
3. The motor is not required to be loaded.

Disadvantages: -

1. In this method, the iron losses are assumed to be constant which is not true as they change from no load to full load.
2. It is difficult to know whether there will be satisfactory commutation at full load as the test is no load test.
3. As it is no load test it cannot be performed on series motor.

### Circuit Diagrams:

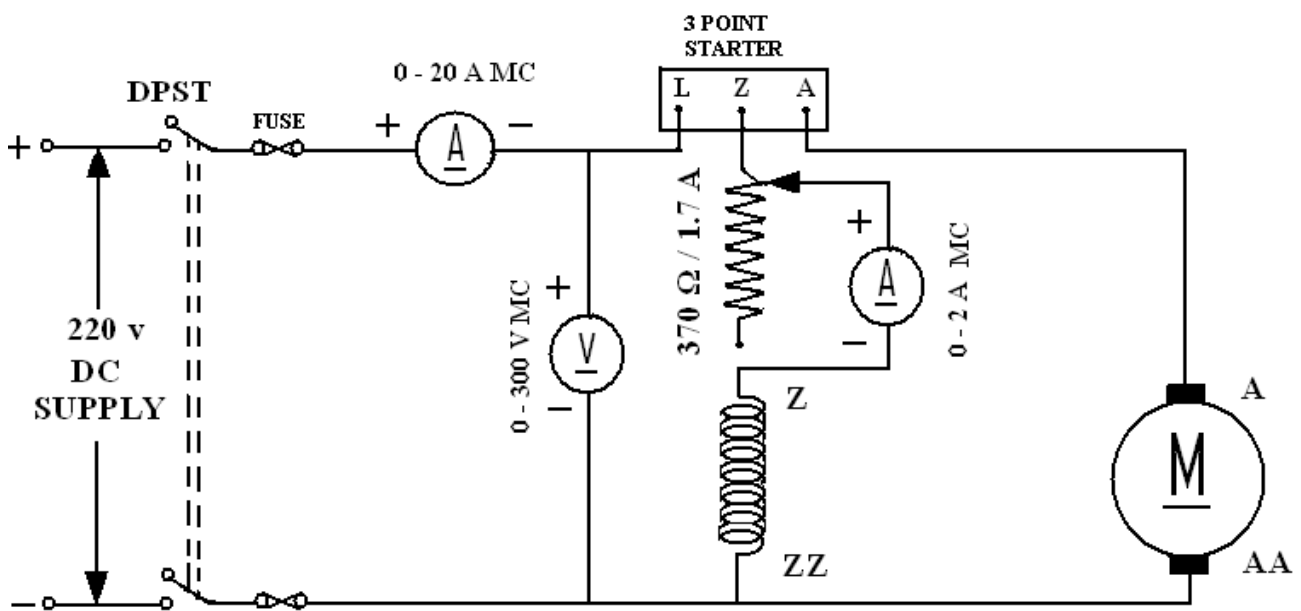

### Procedure:

1. Connect the circuit as per the circuit diagram.
2. Start the motor using 3-point starter.
3. The speed is adjusted to the rated speed with the help of field regulator.
4. The motor is run on no load current at its rated voltage.
5. Note down the readings of no load current, field current & voltage.
6. Measure the resistance of armature of the machine.
7. Calculate the constant loss from the readings.
8. Calculate the efficiency of the machine at different loads when acting as both motor & generator.



**Tabular Forms:**

| Sl. No | Supply voltage<br>VL (V) | Field Current<br>Ish (A) | No load<br>Current<br>IO (A) =<br>(I – Ish) | Armature<br>Resistance<br>Ra (Ω) | Speed<br>N (RPM) |
|--------|--------------------------|--------------------------|---|----------------------------------|------------------|
|        |                          |                          |   |                                  |                  |
|        |                          |                          |   |                                  |                  |
|        |                          |                          |   |                                  |                  |
|        |                          |                          |   |                                  |                  |
|        |                          |                          |   |                                  |                  |
|        |                          |                          |   |                                  |                  |
|        |                          |                          |   |                                  |                  |

**Calculations:**

From the no load test results,  
Supply voltage = VL Volts.  
No load line current = ILO Amperes.  
Field current = If Amperes.  
Therefore No load Armature Current = Iao = IL - If Amperes.  
Resistance cold = Rm  
Effective resistance Re = 1.25 x Rm ohms.  
No load copper losses are = Iao<sup>2</sup> Re  
No load power input = VL IL  
Constant losses = (No load power input - No load copper losses). ----- (1)

**Efficiency as motor:**

Efficiency = output/input = (input – total losses)/ input.  
Where total losses = constant losses + variable losses.  
Constant losses are known value from the equation (1)  
Variable loss = Iao<sup>2</sup> Re, where Iao = IL - If  
Input = VL IL... VL is rated voltage of the machine  
Assume line currents (IL) as 2, 4, 6, ----20A and find corresponding efficiency.

**Efficiency as generator:**

Efficiency = output/input = output / (output + total losses).  
Where losses = constant losses + variable losses  
Constant losses are same for both motor and Generator  
Armature Current = Iao = IL + If  
Variable loss = Iao<sup>2</sup> Re  
Output power = VL IL. VL is rated voltage of the machine  
Assume load currents (IL) as 2, 4, 6, ----20A and find corresponding efficiencies.





### Model Graphs:

1. Efficiency vs Line current for motor.
2. Efficiency vs Line current for generator.

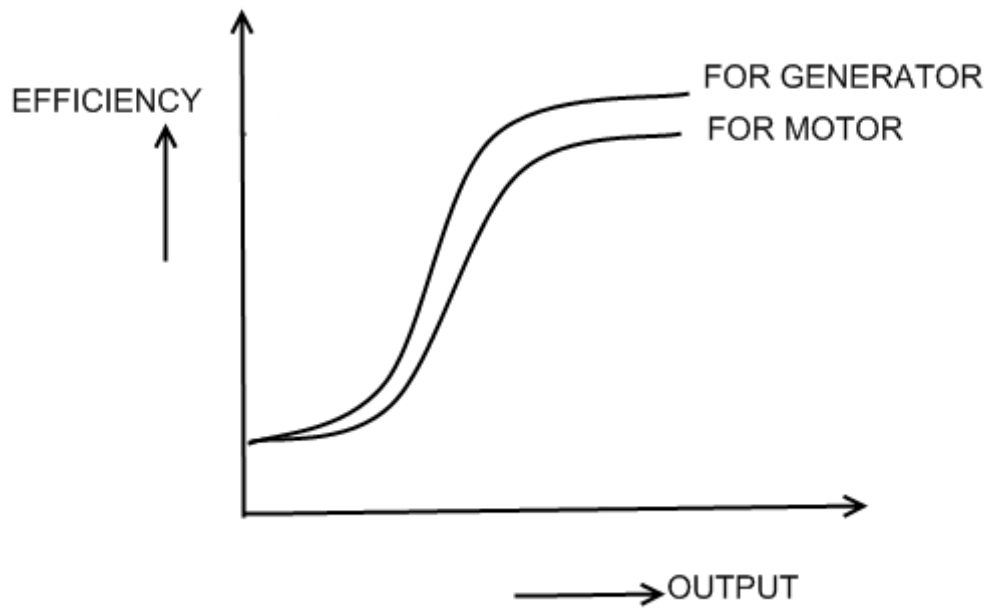

### Result:

### Viva Questions:

1. What are the Losses in dc machines?
2. Define motor?
3. What is the difference between resistor and rheostat?
4. Why we are using 3 point starter in this test?





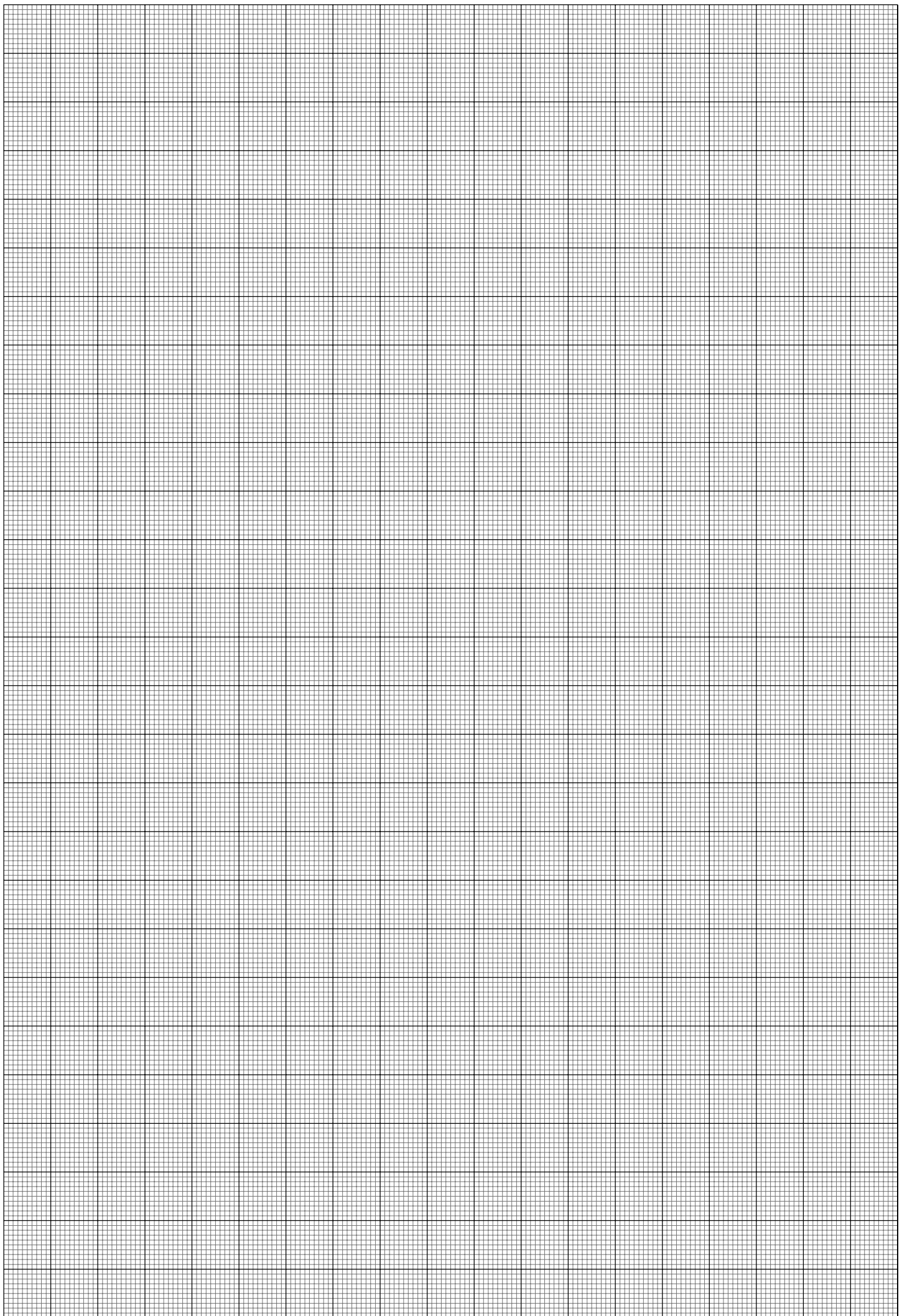

## Expt. No. 12. O.C and S.C Test on a 1- $\phi$ Transformer

**Aim:** To predetermine the efficiency of a single phase transformer.  
To obtain the equivalent circuit of the transformer and  
To find the regulation of the transformer.

### Name Plate Details:

| Sl. No | Parameter | Transformer |
|--------|-----------|-------------|
|        |           |             |
|        |           |             |
|        |           |             |
|        |           |             |

### Apparatus:

| S. No | Equipment Name | Type     | Range            | Qty   |
|-------|----------------|----------|------------------|-------|
| 1     | Voltmeter      | MI       | (0 – 150) V      | 2 No. |
| 2     | Ammeter        | MI       | (0 – 1)A         | 1 No. |
| 3     | Ammeter        | MI       | (0 – 10)A        | 1 No. |
| 4     | Wattmeter      | LPF      | 150V/5A          | 1 No. |
| 5     | Wattmeter      | UPF      | 150V/10A         | 1 No. |
| 6     | Transformer    | 1- phase | 220/110V, 1.8KVA | 1 No. |

### Theory:

#### Open Circuit (or No-Load) Test:

This test is conducted to determine the iron losses (core losses) and parameters  $R_0$  and  $X_0$  of the transformer. In this test, the rated voltage applied to the primary (usually low voltage side) while the secondary is left open circuited. The applied primary voltage  $V_1$  is measured by the Voltmeter, the no load current  $I_0$  by ammeter and no- load input power  $W_0$  by wattmeter. As the normal rated voltage is applied to the primary, therefore, normal Iron losses will occur in the transformer core. Hence wattmeter will record the Iron losses.

Let  $V_1$  = applied rated voltage on L.T side,

$I_0$  = exciting current (or no-load current).

$W_0$  = core loss

Then  $W_0 = V_1 I_0 \cos \theta_0$

No Load p.f. =  $\cos \theta_0 = W_0 / V_1 I_0$ .

$I_w = I_0 \cos \theta_0$  and  $I_m = I_0 \sin \theta_0$

$R_0 = V_1 / I_w$  and  $X_0 = V_1 / I_m$



### Short-Circuit Test:

This test conducted to determine  $R_{01}$  (or  $R_{02}$ ),  $X_{01}$ (or  $X_{02}$ ) and full load copper losses of the transformer. In this test, the secondary (usually  $L_v$  winding) is short circuited and variable low voltage is applied to the primary. The low input voltage is gradually raised till at voltage  $V_{sc}$ , full load current  $I_1$  flows in the primary. Then  $I_2$  in the secondary also has full load value since  $I_1/I_2 = N_2/N_1$  under such conditions copper loss in the windings is the same as that on full load. There is no output from the transformer under short circuit conditions. Therefore, input power is all loss and this loss is entirely copper loss. Hence the wattmeter practically registers the full load copper losses in the transformer windings.

Full load copper loss =  $W_c$

Applied voltage=  $V_{sc}$

Full load primary current =  $I_1$

$W_c = I_1^2 R_{01}$

$R_{01} = W_c / I_1^2$ , where  $R_{01}$  is the total resistance of transformer referred to primary.

Total impedance referred to primary  $Z_{01} = V_{sc} / I_1$

Total leakage reactance referred to primary  $X_{01} = \sqrt{Z_{01}^2 - R_{01}^2}$

Thus short circuit test gives full load copper loss,  $R_{01}$  and  $X_{01}$

### Circuit Diagrams:

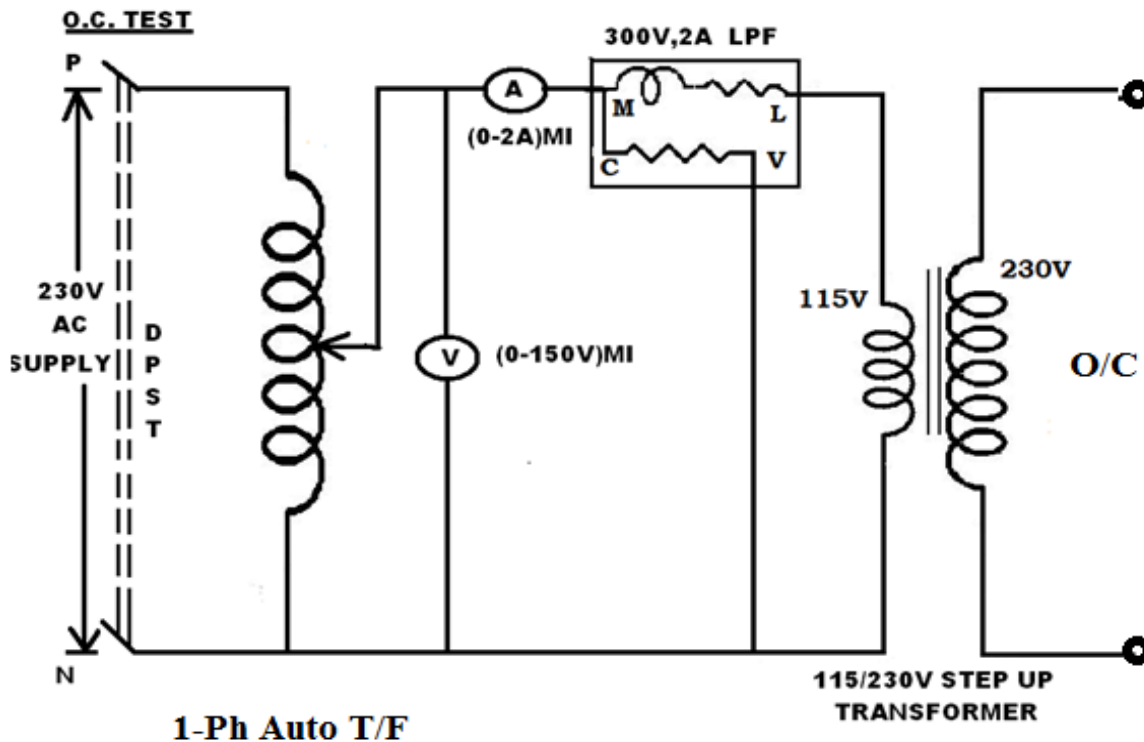

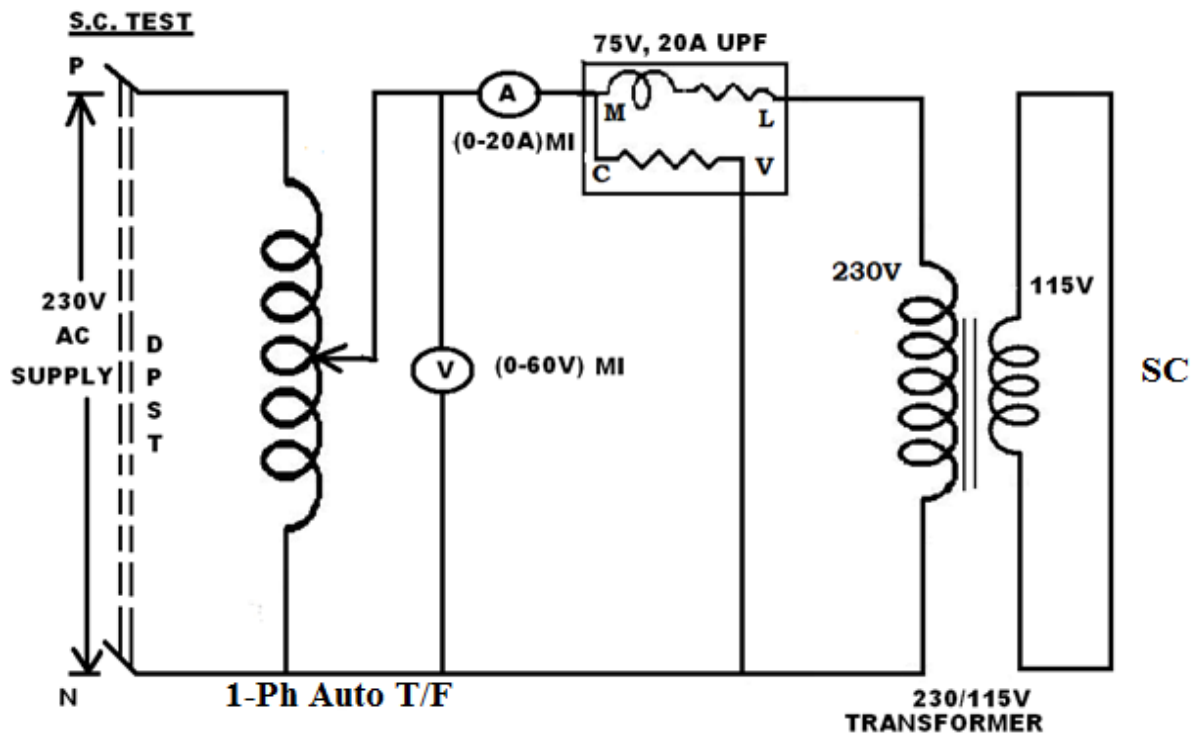

**Procedure:**

**(a) Open Circuit Test (O.C Test):**

1. Make the connections as per the circuit diagram, the 220V winding of the transformer is kept open
2. Apply the rated voltage, i.e. 110V through the auto transformer.
3. Note down the voltmeter  $V_{oc}$ , ammeter  $I_{oc}$  and wattmeter  $W_{oc}$  readings and tabulate
4. Now reduce the voltage given to the transformer to Zero and Switch off the supply.
5. Calculate the values of  $R_0$  and  $X_0$ .
6. The wattmeter used in the OC test should be low power factor wattmeter, since it must be able to measure power at low power factor at which the transformer works on no load.

**(b) Short Circuit Test (S.C Test):**

1. Make the connections as per the circuit diagram and keep the 110V winding of the transformer short circuited.
2. Apply the low voltage side through the auto transformer and increase the voltage gradually till the full load current flows in the 220V winding.
3. Note down the voltmeter, ammeter and wattmeter readings.
4. Reduce the voltage given to the transformer to zero and switch off the supply.
5. Calculate values of  $R_{01}$  or  $R_{02}$  and  $X_{01}$  or  $X_{02}$ .
6. Draw the equivalent circuit diagram of the 1- $\Phi$  transformer.

**Tabular Forms:**

**O.C Test:**

| S. NO | Vo.c (volts) | Io (amps) | Po (watts) |
|-------|--------------|-----------|------------|
|       |              |           |            |

**SC Test:**

| S. NO | Vs.c (volts) | Isc (amps) | Psc (watts) |
|-------|--------------|------------|-------------|
|       |              |            |             |

**To draw Equivalent circuit:**

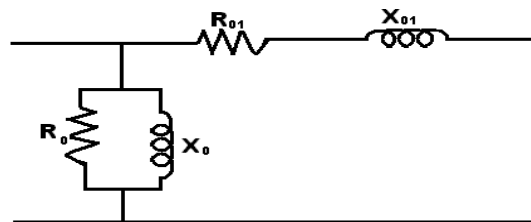

$$P_0 = \text{Iron Loss} = I_0 V_0 \cos \phi_0$$

$$\cos \phi_0 = P_0 / (V_0 \times I_0), \quad \phi_0 = \cos^{-1} P_0 / (V_0 \times I_0)$$

$$R_0 = V_0 / (I_0 \cos \phi_0) = V_0 / I_w$$

$$X_0 = V_0 / (I_0 \sin \phi_0) = V_0 / I_\mu$$

$$P_{sc} = \text{Copper Loss} = I_{sc}^2 \times R_{01}$$

$$R_{01} = P_{sc} / I_{sc}^2$$

$$Z_{01} = V_{sc} / I_{sc}$$

$$X_{01} = \sqrt{Z_{01}^2 - R_{01}^2}$$

Load at which max efficiency occurs is the same whatever the power factor, However numerical value of “ $\eta$ ” decreases with decrease in P.F.

**TO CALCULATE THE EFFICIENCY AT U.P.F/0.8 PF/0.6 P.F:**

| S.No              | Load      | Load Current<br>$I_L$<br>(Amps) | Iron Loss<br>$P_0$<br>(Watts) | Copper Loss<br>$P_{sc}$<br>(Watts) | Total Loss $P_0 + P_{sc}$<br>(Watts) | Output<br>KVA X<br>P.f | Input =<br>Output +<br>Losses | $\eta =$<br>Output<br>/Input |
|-------------------|-----------|---------------------------------|-------------------------------|------------------------------------|--------------------------------------|------------------------|-------------------------------|------------------------------|
| <b>At U.P.F</b>   |           |                                 |                               |                                    |                                      |                        |                               |                              |
|                   | Full Load |                                 |                               |                                    |                                      |                        |                               |                              |
|                   | ½ Load    |                                 |                               |                                    |                                      |                        |                               |                              |
|                   | ¼ Load    |                                 |                               |                                    |                                      |                        |                               |                              |
|                   | ¾ Load    |                                 |                               |                                    |                                      |                        |                               |                              |
| <b>At 0.8 P.F</b> |           |                                 |                               |                                    |                                      |                        |                               |                              |
|                   | Full Load |                                 |                               |                                    |                                      |                        |                               |                              |
|                   | ½ Load    |                                 |                               |                                    |                                      |                        |                               |                              |
|                   | ¼ Load    |                                 |                               |                                    |                                      |                        |                               |                              |
|                   | ¾ Load    |                                 |                               |                                    |                                      |                        |                               |                              |
| <b>At 0.6 P.F</b> |           |                                 |                               |                                    |                                      |                        |                               |                              |
|                   | Full Load |                                 |                               |                                    |                                      |                        |                               |                              |
|                   | ½ Load    |                                 |                               |                                    |                                      |                        |                               |                              |
|                   | ¼ Load    |                                 |                               |                                    |                                      |                        |                               |                              |
|                   | ¾ Load    |                                 |                               |                                    |                                      |                        |                               |                              |

### Expected Graphs:

- 1) Efficiency
- 2) Iron Loss
- 3) Cu Loss

And from the graph find the condition for efficiency to be maximum,

(1) Efficiency:

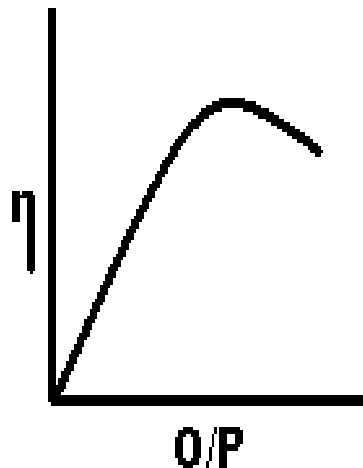

(2) Iron Loss:

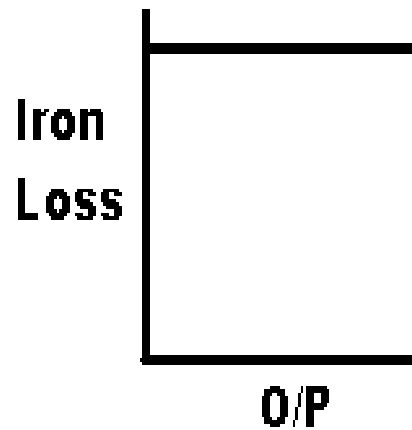

(3) Cu. Loss:

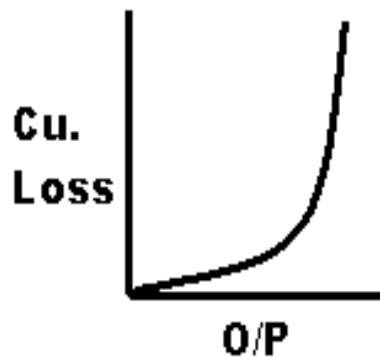

Result:

### Viva Questions:

- 1) Explain why the wattmeter reading in O.C Test is taken as Iron Loss?
- 2) Explain why the wattmeter reading in S.C Test is taken as Copper Loss?
- 3) What are the uses of transformers, explain with example?
- 4) Why the efficiency of the transformer is high as compared to the electrical motor?
- 5) What are the materials used for making the core and winding of the transformer?
- 6) Explain why those materials are used?
- 7) What do you understand by an Auto-transformer?
- 8) Why transformer rating is in KVA not KW.
- 9) What is the all day efficiency of a transformer?





